



## LAKWOOD CITY COUNCIL STUDY SESSION AGENDA

Monday, November 28, 2022

7:00 P.M.

City of Lakewood

Council Chambers

6000 Main Street SW

Lakewood, WA 98499

Residents can virtually attend City Council meetings by watching them live on the city's YouTube channel:

<https://www.youtube.com/user/cityoflakewoodwa>

Those who do not have access to YouTube can call in to listen by telephone via Zoom: Dial +1(253) 215-8782 and enter meeting ID: 868 7263 2373

---

Page No.

### CALL TO ORDER

### ITEMS FOR DISCUSSION:

- (3) 1. Joint Youth Council meeting. – (Work Plan)
2. Sound Transit Access Improvement Project Update. – *Zachary Eskenzai, Project Manager*
- (5) 3. Review of revised Bristol Apartments Multi-Family Tax Exemption (9615 Bristol Ave SW, Parcel Number 9820000020). – (Memorandum)
- (50) 4. Review of American Rescue Plan Act (APRA) Request for Proposals. – (Memorandum)
- (128) 5. Review of Lakewood Library Fiscal Analysis. – (Memorandum)

### ITEMS TENTATIVELY SCHEDULED FOR THE DECEMBER 5, 2022 REGULAR CITY COUNCIL MEETING:

1. Proclamation and Recognition of Michele Johnson, Ph.D., Pierce College Chancellor.
2. Youth Council Report.
3. Clover Park School District Report.

*Persons requesting special accommodations or language interpreters should contact the City Clerk, 253-983-7705, as soon as possible in advance of the Council meeting so that an attempt to provide the special accommodations can be made.*

4. Reappointing Laurie Maus and Edith Owen Wallace to serve on the Community Services Advisory Board through December 15, 2026. – (Motion – Consent Agenda)
5. Authorizing the execution of a construction contract for the Springbrook Park project. – (Motion – Consent Agenda)
6. Authorizing the execution of an agreement for Hearings Examiner services. – (Motion – Consent Agenda)
7. This is the date set for a public hearing to vacate that portion of 113<sup>th</sup> Street SW lying west of the westerly margin of Kendrick Street. – (Public Hearings and Appeals – Regular Agenda)
8. Approving the 2023 Comprehensive Plan and Zoning Map Amendment Docket. – (Ordinance – Regular Agenda)
9. Authorizing the issuance of Conditional Certificate of Acceptance of Tax Exemption within a Residential Target Area to Kurkov Konstantin (Bristol Apartments). – (Resolution – Regular Agenda)
10. Approving the 2023 Human Services funding recommendations. – (Motion – New Business)

## **REPORTS BY THE CITY MANAGER**

## **CITY COUNCIL COMMENTS**

## **ADJOURNMENT**

*Persons requesting special accommodations or language interpreters should contact the City Clerk, 253-983-7705, as soon as possible in advance of the Council meeting so that an attempt to provide the special accommodations can be made.*

# City of Lakewood Youth Council

## WORK PLAN AND SIGNIFICANT ACCOMPLISHMENTS

**Members:**

|  |                            |
|--|----------------------------|
| Co-Chairs: Hank Jones & Brandon Elliot         | Alli Laska                 |
| Communications Manager: Angel Calderon Ramirez | Cynthia Lemus Rodriguez    |
| Adrianna Bhan                                  | Ariana Melo                |
| Kera Buckmaster                                | Kaitlyn Miller             |
| Selena Corona Hernandez                        | Anthony Naranjo            |
| Kimberly Estrada                               | Kloe Salazar               |
| Anaya Davis                                    | Jhoselyn Valenzuela Mendez |
| Keilani Fernandez                              | Leslie Valenzuela Mendoza  |
| Miguel Gasper Dominguez                        | Mayumi Remedios            |
| Fatima Hernandez                               | Chase Washington           |
| Chai Hill                                      | Dangelo A. Rodriguez       |
| Violet Johnson                                 |                            |
| Lexus Drebaum                                  |                            |

**Council Liaison:**

Councilmember Mike Brandstetter

**City Staff Support:**

Shannon Bennett, Human Services Coordinator  
 Cameron Fairfield, Recreation Services Coordinator

**Meeting Schedule:**

First Monday of Each Month at 5:00pm / Present to Council at 7:00pm  
 2nd meeting of the month as needed

**Overview:** The role of the Youth Council is to convey to the Lakewood City Council issues having city-wide impact to youth. Members are responsible for a monthly report to City Council and may participate on a variety of city committees, study groups and task forces.

**Year-End Summary:** The Youth Council hosted their annual youth summit which focused on youth mental health, workforce development, and financial literacy. The event included guest speakers, a vendor expo, break-out sessions, and was well attended by Clover Park grades 7-12 students.

**Accomplishments:**

| Date                                   | Topic(s)  |
|--|---|
| 1/10/22<br>(2 <sup>nd</sup><br>Monday) | Regular Meeting: <ul style="list-style-type: none"> <li>• Climate change perception study</li> <li>• Youth Summit Discussion</li> </ul>   |
| 2/7/22                                 | Regular Meeting: <ul style="list-style-type: none"> <li>• Conversation with YMCA               <ul style="list-style-type: none"> <li>○ Available programs</li> <li>○ Job opportunities</li> <li>○ Youth Voice</li> </ul> </li> </ul> |
| 3/7/22                                 | Regular Meeting: <ul style="list-style-type: none"> <li>• Youth Summit Planning</li> </ul>  |

|                     |   |
|---------------------|---|
| 4/4/22              | Regular Meeting: <ul style="list-style-type: none"> <li>• Presentation of Economic Development Strategy Plan &amp; Discussion</li> <li>• Youth Mental Health First Aid discussion with Boys &amp; Girls Club staff</li> </ul> |
| 5/2/22              | Regular Meeting: <ul style="list-style-type: none"> <li>• Teens of Destiny conversation with Korean Women's Association staff</li> </ul>  |
| 5/26/22<br>Saturday | Hosted 2022 Youth Summit <ul style="list-style-type: none"> <li>• Vendor Expo</li> <li>• Break-out Session</li> <li>• Guest Speakers</li> <li>• Puyallup Tribe Drum Welcome Ceremony</li> </ul>                               |
| 6/6/22              | Regular Meeting: <ul style="list-style-type: none"> <li>• Youth Summit de-brief</li> <li>• Year end recap.</li> </ul>   |

**(Current Year) Work Plan:**

|            |  |
|------------|--|
| 8/26/22    | Youth Council Kick-Off Event   |
| 9/12/2022  | Regular Meeting<br>First Meeting / Introductions / Purpose of the Board / Meeting Expectations   |
| 10/03/2022 | Regular Meeting: <ul style="list-style-type: none"> <li>• Chose Advisory Board and Commission Youth Council Representatives</li> </ul>   |
| 10/21/2022 | Planning Meeting: <ul style="list-style-type: none"> <li>• Determined details for first YC hosted roundtable discussion</li> <li>• Determined 2023 Youth Summit will be held on May 27<sup>th</sup></li> </ul>   |
| 11/07/2022 | Regular Meeting: <ul style="list-style-type: none"> <li>• Sustainable Solutions discussion with Pierce County Equity and Engagement representatives and</li> <li>• YC involvement in City social media efforts discussion with Communications Manager</li> </ul> |
| 12/05/2022 | Regular Meeting: <ul style="list-style-type: none"> <li>• Confirm details of 12/9 roundtable discussion and</li> <li>• Confirm details of YC participation in 12/10 Christmas Parade.</li> </ul>   |
| 12/09/2022 | Host Roundtable discussion at CPHS. Topic: homeless / youth homelessness.  |
|            |  |





TO: Mayor and City Councilmembers

FROM: Becky Newton, Economic Development Manager and Dave Bugher,  
Assistant City Manager, Community & Economic Development  
Director

THROUGH: John J. Caulfield, City Manager *John J. Caulfield*

DATE: November 28, 2022

SUBJECT: Review of revised Bristol Apartments multifamily tax exemption  
(9615 Bristol Ave SW, parcel number 9820000020)

**Purpose:** The purpose of this memo is to present a project proposal for a multi-family tax exemption project located in the City's CBD Residential Target Area.

**Background:** An application for twelve-year tax exemption was filed with the City of Lakewood on April 18, 2022. This project was presented to City Council on June 21, 2022. Ownership in the property has since changed hands and the new owner requested that the multifamily tax exemption (MFTE) project be changed from 100% affordable housing to 20% affordable housing. A new MFTE application was received on July 18, 2022. All other elements remain the same.

We have reviewed the application and made the following findings related to LMC 3.64.020:

1. The proposed project is located within a designated Residential Target Area;
2. The proposed project meets the definition of multi-family housing pursuant to the Lakewood Municipal Code;
3. At least 50 percent of the space will be designated for multifamily housing offering permanent residential occupancy;
4. The construction is proposed to be completed within 3 years of the date of approval of the application;

5. The project complies with the City’s comprehensive plan. Additional permits including: design review, site development and building permits are required. The project must comply with all applicable regulations in effect.;
6. The project complies with the City’s municipal code 18B for the Downtown subarea;
7. There are no existing dwelling units on-site;
8. The applicant has committed to renting at least 20% of the multifamily housing units as affordable housing<sup>i</sup> units to low-and moderate-income households.

**Project Description:** The applicant proposes to redevelop approximately 0.14 acres (6,119 SF) located at 9615 Bristol Ave SW in the City of Lakewood, Washington; Pierce County Assessor’s Parcel (APN) #9820000020. The property is located on the east side of Bristol Ave SW. The proposed development use type, *Multi-Family, four or more residential units*, is a primary permitted use in the applicable Central Business District (CBD) zoning district. The applicant has agreed to improvements in compliance Title 18B of the Lakewood Municipal Code.

The parcel is currently vacant. The new development will consist of 7, one-bedroom multifamily units and one office space within one building. The building is three stories tall with private decks for each unit. There are four garage parking spaces, and seven parking lot spaces, including two handicap parking units (one van accessible). The total building square footage is approximately 1,974 square feet. The project is proposing to fulfill affordable housing mandates as outlined in Chapter 3.64 of the Lakewood Municipal Code. The project will set aside 20% of all units for affordable housing.

**Next Steps:** The project meets all of the requirements for a twelve year tax exemption. The Lakewood Municipal Code requires a signed contract between the applicant and the City which is to be approved by resolution.

1. It is recommend that the City Council review and provide comments regarding the project proposal and the “Agreement Regarding Residential Target Area Development” (attached).
2. On December 5, 2022, we will present a resolution to adopt a housing tax exemption contract for the proposed housing tax exemption between Kurkov Konstantin, and the City of Lakewood.

**Attachments:**

1. Project Application
2. Proposed Project Site Plan with Elevations
3. Draft Resolution
4. Draft Conditional Certificate of Multi-Family Tax Exemption
5. Draft Agreement Regarding Residential Target Area Development
6. Project PowerPoint Presentation

---

<sup>ii</sup> Affordable housing includes low-and moderate income households. These terms are defined in RCW 84.14.010 as: " 'Low-income household' means a single person, family, or unrelated persons living together whose adjusted income is at or below eighty percent of the median family income adjusted for family size, for

---

the county where the project is located, as reported by the United States department of housing and urban development. For cities located in high-cost areas, 'low-income household' means a household that has an income at or below one hundred percent of the median family income adjusted for family size, for the county where the project is located.

'Moderate-income household' means a single person, family, or unrelated persons living together whose adjusted income is more than eighty percent but is at or below one hundred fifteen percent of the median family income adjusted for family size, for the county where the project is located, as reported by the United States department of housing and urban development. For cities located in high-cost areas, 'moderate-income household' means a household that has an income that is more than one hundred percent, but at or below one hundred fifty percent, of the median family income adjusted for family size, for the county where the project is located.

According to the United States Department of Housing and Urban Development, Pierce County is part of the Tacoma, WA HUD Metro Area, as published on the *2021 Income Limits Summary*, prepared by the Program and Parameters Research Division, HUD, the Median Family Income for a family of 4 is \$91,100. Low to moderate-income would range from \$72,880- \$104,765 for a family of 4.



## Application – Conditional Certificate of Tax Exemption for Multiple Family Units Located within a Residential Target Area

6000 Main Street SW. Lakewood, WA 98499  
Telephone: (253) 512-2261

Application Fee: \$800.00

| Number Required:  | Description of Required Documents:   | Required: |
|---|--|-----------|
| 1   | Conditional Certificate of Tax Exemption Application.  | A         |
| 2 sets  | Preliminary floor and site plans of the proposed project.  | A         |
| 1   | 8 1/2" x 11" reduced copy of the preliminary floor and site plans.   |           |
| 1   | A statement acknowledging the potential tax liability when the project ceases to be eligible for the tax exemption   | A         |
| 1   | Verification by oath or affirmation of the information submitted.  | A         |
| 1   | For rehabilitation projects, the applicant shall also submit an affidavit that existing dwelling units have been unoccupied for a period of twelve (12) months prior to filing the application and shall secure from the City verification of property noncompliance with the City's minimum housing code. | A         |
| 1   | If applicable, a statement that the project meets the affordable housing requirements as described in RCW 84.14.020.   | A         |
| Preliminary floor and site plans may be submitted in electronic PDF format. |  |           |

A = Always required.  
M = May be required.



## Application – Conditional Certificate of Tax Exemption for Multiple Family Units Located within a Residential Target Area

### Program Requirements

***Project must meet the following criteria for special valuation on multifamily property:***

1. The project must be located within a Residential Target Area.
2. The project must not displace existing residential tenants of structures that are proposed for redevelopment. Existing dwelling units proposed for rehabilitation must have been unoccupied for a minimum of 12 months prior to submission of an application and must have one or more violations of the City's minimum housing code. Applications for new construction cannot be submitted for vacant property upon which an occupied residential rental structure previously stood, unless a minimum of 12 months has elapsed from the time of most recent occupancy.
3. The project must include at least four units of multi-family housing within a residential structure or as part of a mixed-use development. A minimum of four new units must be constructed or at least four additional multi-family units must be added to existing occupied multi-family housing. Existing multi-family housing that has been vacant for twelve (12) months or more does not have to provide additional units so long as the project provides at least four units of new, converted, or rehabilitated multi-family housing.
4. At least fifty (50) percent of the space designated for multi-family housing must be provided for permanent residential occupancy.
5. Proposed Completion Date. New construction multi-family housing and rehabilitation improvements must be scheduled to be completed within three years from the date of approval of the application.
6. The project must be designed to comply with the City's comprehensive plan, building, housing, and zoning codes, and any other applicable regulations in effect at the time the application is approved. Rehabilitation and conversion improvements must comply with the City's minimum housing code. New construction must comply with the International Building Code. The project must also comply with any other standards and guidelines adopted by the City Council for the Residential Target Area in which the project will be developed.

***Once this application is approved, then:***

1. The applicant and the City will execute a contract to be approved by the City Council under which the applicant agrees to implementation of the development on terms and conditions satisfactory to the City Council.

2. Once this contract is executed, the City will issue a Conditional Certificate of Acceptance of Tax Exemption based on the information provided by the applicant. The Conditional Certificate will be effective for not more than three years, but may be extended for an additional 24 months under certain circumstances.
3. Once the project is completed and all contract terms have been fulfilled, at the applicant's request, the applicant will receive an application for Final Certificate of Tax Exemption, which the applicant must complete and return to the City of Lakewood Community & Economic Development Department.
4. Upon approval of the application for Final Certificate of Tax Exemption, the City will within 40 days of application, file the Final Certificate of Tax Exemption with the Pierce County Assessor's Office.

Please Note: The Pierce County Assessor may require the applicant to submit pertinent data regarding the use of classified land.



# Application – Conditional Certificate of Tax Exemption for Multiple Family Units Located within a Residential Target Area

## APPLICATION INFORMATION

Date: \_\_\_\_\_ Name of Applicant: \_\_\_\_\_

Business Name of Applicant: \_\_\_\_\_

Mailing Address: \_\_\_\_\_

Telephone: \_\_\_\_\_ Cell Phone: \_\_\_\_\_

Email: \_\_\_\_\_

## PROJECT INFORMATION

### Property Description

Name of Project: \_\_\_\_\_

Street Address of Project: \_\_\_\_\_

County Assessor Parcel Number(s): \_\_\_\_\_

Term of Exemption Applying for:

8 years       12 years

Interest in Property: \_\_\_\_\_

Other (description): \_\_\_\_\_

### Type of Construction

New Construction: \_\_\_\_\_  Yes       No

*If rehabilitation/demolition, applicant must secure from the City verification of property*

noncompliance with applicable building codes.

**Intended Project Construction Timeline(s):** \_\_\_\_\_

**Number & Type of Units**

Number of Units – New \_\_\_\_\_ Number of Units – Rehabilitated \_\_\_\_\_

Are the total numbers of units more than the number of units for which you are requesting a Tax Exemption?

Yes  No

Number of Units Proposed: Studio \_\_\_\_\_ One Bedroom \_\_\_\_\_ Two Bedroom \_\_\_\_\_

Other \_\_\_\_\_

Number and percentage of affordable units (if any): \_\_\_\_\_

**Description of Building Use**

Required Preliminary Plans are Attached:

Site Plan  Yes  No Floor plans  Yes  No

Describe building use and square feet intended for use:

1st Floor 1,974sqft retail space, 1bed and 4 car garage

2nd Floor 2,033. 3 one bed units

3rd Floor 2,033. 3 one bed units

Total sqft 6,040

Identify square feet of commercial space (if any): \_\_\_\_\_

**Cost of Construction** Project cost of new construction/rehabilitation: \_\_\_\_\_

Source of Cost Estimate: \_\_\_\_\_

Expected Date to Start Project: \_\_\_\_\_

Expected Date to Complete Project: \_\_\_\_\_

Provide a brief statement describing the project and setting forth the grounds for qualifications for tax exemptions in the space below (attach additional information if necessary):





*(Please attach additional information if necessary.)*

**AFFIRMATIONS**

- I understand that the value of new housing construction, conversion, and rehabilitation improvements qualifying under this chapter is exempt from ad valorem property taxation for eight (8) successive years for market rate housing, and twelve (12) successive years for qualified affordable housing multi-family projects beginning January 1st of the year immediately following the calendar year of issuance of the Final Certificate of Tax Exemption eligibility. \_\_\_\_\_ (initial)
  
- I understand that by December 15th of each year and/or within 30 days after the first anniversary of the date of filing the Final Certificate of tax Exemption and each year thereafter, I will be required to file a report with the City of Shoreline that provides detailed information concerning rental rates, occupancy, and tenant incomes during the year. \_\_\_\_\_ (initial)

- I understand at the conclusion of the exemption period, the new or rehabilitated housing cost shall be considered as new construction for the purposes of chapter 84.55 RCW. \_\_\_\_\_ (initial)
- I am aware of the potential tax liability involved when the property ceases to be eligible for the tax exemption incentive. \_\_\_\_\_ (initial)
- I affirm that the submitted information is true and correct, subject to penalty of perjury under the law of the State of Washington.

Signed the \_\_\_\_\_ day of \_\_\_\_\_, 20\_\_\_\_ .

Applicant Signature:  \_\_\_\_\_



# BRISTOL APARTMENTS

## 9615 BRISTOL AVE SW LAKEWOOD, WA

PROJ ID 643  
PERMIT 900

RECEIVED  
10/10/2022  
City of Lakewood



1910 EAST 4TH AVENUE PMB #170  
OLYMPIA, WA 98506  
PHONE: 360-528-0513  
JOSH@REVIVALARCHITECTS.COM

LJB DESIGNS, LLC  
111 Market Street N.E., Suite 325  
Olympia, Washington 98501  
(360) 867-1945

E-mail: LJBDesigns@Comcast.net

REVISIONS

| # | ISSUED | DATE |
|---|--------|------|
|---|--------|------|



2015 REGISTERED ARCHITECT  
JOSHUA EARL SNODGRASS  
STATE OF WASHINGTON

### ABBREVIATIONS

|          |                                       |          |  |          |                               |
|----------|---------------------------------------|----------|--|----------|-------------------------------|
| <b>A</b> | ATTIC ACCESS                          | <b>G</b> | GAGE                                       | <b>R</b> | RISER                         |
| AA       | ANCHORBOLT                            | GALV     | GALVANIZED                                 | R & S    | ROD & SHELF                   |
| ABV      | ABOVE                                 | GAR      | GARAGE                                     | RAD      | RADIUS                        |
| ACC      | ACCESSIBLE                            | GE       | GRAB BAR                                   | RC       | RESILIENT CHANNEL             |
| ACOUS    | ACOUSTICAL                            | GENL     | GENERAL                                    | RCP      | REFLECTED CEILING PLAN        |
| ADA      | AMERICANS WITH DISABILITIES ACT       | GL       | GLASS                                      | RD       | ROOF DRAIN                    |
| ADDL     | ADDITIONAL                            | GLU LAM  | GLUE LAMINATED                             | REF      | REFER (ENCE), REFRIGERATOR    |
| ADJ      | ADJUSTABLE                            | GOVT     | GOVERNMENT                                 | REINF    | REINFORCE (D), (ING)          |
| AFF      | ABOVE FINISH FLOOR                    | GYP      | GYPSPUM                                    | REQD     | REQUIRED                      |
| AL       | ALUMINUM                              | GWB      | GYPSPUM WALL BOARD                         | RESID    | RESIDENTIAL                   |
| ALT      | ALTERNATE                             |          |  | RESIL    | RESILIENT                     |
| APPROX   | APPROXIMATE                           | <b>H</b> | HIGH                                       | REV      | REVISION (S), REVISED         |
| APT      | APARTMENT                             | H        | HOSE BIBB                                  | RFG      | ROOFING                       |
| ARCH     | ARCHITECT (URAL)                      | HC       | HANDICAPPED                                | RM       | ROOM                          |
| AVE      | AVENUE                                | HDWD     | HARDWOOD                                   | RO       | ROUGH OPENING                 |
|          |                                       | HDWE     | HARDWARE                                   | ROW      | RIGHT OF WAY                  |
|          |                                       | HGT      | HEIGHT                                     |          |                               |
| <b>B</b> | BOARD                                 | HM       | HOLLOW METAL                               | <b>S</b> | SINK                          |
| BBBS     | BLOWN IN BATT SYSTEM                  | HR       | HOTWATER FAN COIL UNIT                     | S        | SOUTH                         |
| BITUM    | BITUMINOUS                            | HTR      | HEATER                                     | SAT      | SUSPENDED ACOUSTICAL TILE     |
| BLDG     | BUILDING                              | HVAC     | HEATING, VENTILATION, AND AIR CONDITIONING | SBC      | SEATTLE BUILDING CODE         |
| BLKG     | BLOCKING                              |          |  | SCHED    | SCHEDULE                      |
| BLVD     | BOULEVARD                             |          |  | SF       | SQUARE FOOT                   |
| BM       | BEAM                                  |          |  | SHF      | SHELF                         |
| BO       | BOTTOM OF                             |          |  | SHT      | SHEET                         |
| BOT      | BOTTOM                                |          |  | SHTG     | SHEATHING                     |
| BR       | BEDROOM                               |          |  | SHV      | SHELVES (ING)                 |
| BSMT     | BASEMENT                              |          |  | SI       | SQUARE INCH                   |
| BUR      | BUILT UP ROOF                         |          |  | SIM      | SIMILAR                       |
|          |                                       |          |  | SP       | STANDPIPE                     |
|          |                                       |          |  | SPEC     | SPECIFICATION                 |
| <b>C</b> | CABINET                               |          |  | SPKLR    | SPRINKLER                     |
| CALC     | CALCULATION                           | <b>I</b> | INTERNATIONAL BUILDING CODE                | SQ       | SQUARE                        |
| CB       | CATCH BASIN                           | ID       | INSIDE DIAMETER                            | SS       | SANITARY SEWERS               |
| CER      | CERAMIC TILE                          | IIC      | IMPACT INSULATION CLASS                    | ST       | STAINLESS STEEL               |
| CIP      | CAST-IN-PLACE (CONCRETE)              | INCL     | INCLUDING                                  | ST       | STREET                        |
| CL       | CENTERLINE                            | INSUL    | INSULATION                                 | STC      | SOUND TRANSMISSION CLASS      |
| CLG      | CEILING                               | INT      | INTERIOR                                   | STOR     | STORAGE                       |
| CLR      | CLEAR                                 | IRC      | INTERNATIONAL RESIDENTIAL CODE             | STRUCT   | STRUCTURE                     |
| CMU      | CONCRETE MASONRY UNIT                 |          |  | SUSP     | SUSPENDED                     |
| COL      | CLEAN OUT                             |          |  | SYS      | SYSTEM                        |
| COLM     | COLUMN                                | <b>L</b> | LEFT, LONG                                 |          |                               |
| CONC     | CONCRETE                              | LAM      | LAMINATE(D)                                | <b>T</b> | TREAD                         |
| CONT     | CONTINUOUS                            | LAU      | LAUNDRY                                    | T&G      | TONGUE AND GROOVE             |
| CONTR    | CONTRACT (OR)                         | LAV      | LAVATORY                                   | TB       | TOWEL BAR - 24" UNO           |
| COORD    | COORDINATE                            | LB       | POUND                                      | TEL      | TELEPHONE                     |
| CORR     | CORRIDOR                              | LOC      | LOCATION                                   | TEMP     | TEMPORARY                     |
| CPT      | CARPET (ED)                           | LR       | LIVING ROOM                                | THK      | THICK (NESS)                  |
| CSMT     | CASEMENT                              | LRG      | LARGE                                      | THRU     | THROUGH                       |
| CT       | CARPET TILE                           | LT       | LIGHT                                      | TOB      | TOP OF BEAM                   |
|          |                                       | LTG      | LIGHTING                                   | TOC      | TOP OF CURB                   |
| <b>D</b> | DRYER, DEEP                           |          |  | TOD      | TOP OF DRAIN                  |
| DEMO     | DEMOLISH, DEMOLITION                  |          |  | TOFF     | TOP OF FINISH FLOOR           |
| DEPT     | DEPARTMENT                            | <b>M</b> | MASONRY                                    | TOT      | TOTAL                         |
| DET      | DETAIL                                | MATL     | MATERIAL                                   | TOW      | TOP OF WALL                   |
| DF       | DRINKING FOUNTAIN                     | MAX      | MAXIMUM                                    | TR       | TOWEL RING                    |
| DIAM     | DIAMETER                              | MBR      | MASTER BEDROOM                             | TV       | TELEVISION                    |
| DIM      | DIMENSION                             | MECH     | MECHANICAL                                 | TYP      | TYPICAL                       |
| DN       | DOWN                                  | MC       | MEDICINE CABINET                           |          |                               |
| DO       | DITTO                                 | MEMB     | MEMBRANE                                   | <b>U</b> | UNIFORM BUILDING CODE         |
| DR       | DINING ROOM, DOOR                     | MET      | METAL                                      | UNFIN    | UNFINISHED                    |
| DS       | DOWNSPOUT                             | MEZZ     | MEZZANINE                                  | UNO      | UNLESS NOTED OTHERWISE        |
| DW       | DISHWASHER                            | MFR      | MANUFACTURE (R)                            | UTIL     | UTILITY                       |
| DWG      | DRAWING                               | MIN      | MINIMUM, MINUTE                            |          |                               |
| DWR      | DRAWER                                | MISC     | MISCELLANEOUS                              | <b>V</b> | VAPOR BARRIER                 |
|          |                                       | MO       | MASONRY OPENING                            | VCT      | VINYL COMPOSITION TILE        |
|          |                                       | MULT     | MULTIPLE                                   | VEH      | VEHICLE                       |
| <b>E</b> | EAST                                  |          |  | VERT     | VERTICAL                      |
| EA       | EACH                                  | <b>N</b> | NORTH                                      | VIF      | VERIFY IN FIELD               |
| EIFS     | EXTERIOR INSULATION AND FINISH SYSTEM | NA       | NOT APPLICABLE                             | VIN      | VINYL                         |
| EL       | ELEVATION                             | NIC      | NOT IN CONTRACT                            | VT       | VINYL TILE                    |
| ELEC     | ELECTRIC (AL)                         | NO       | NUMBER                                     |          |                               |
| ELEV     | ELEVATOR                              | NOM      | NOMINAL                                    | <b>W</b> | WEST, WIDE, WASHER            |
| ENCL     | ENCLOSE (URE)                         | NTS      | NOT TO SCALE                               | W        | WITH                          |
| EP       | ELECTRICAL PANEL                      |          |  | WD       | WASHER / DRYER                |
| EQ       | EQUAL                                 | <b>O</b> | ON CENTER                                  | WO       | WITHOUT                       |
| EQUIP    | EQUIPMENT                             | OD       | OUTSIDE DIAMETER                           | WAC      | WASHINGTON ACCESSIBILITY CODE |
| ESMT     | EASEMENT                              | OFI      | OWNER FURNISHED & INSTALLED                | WC       | WATER CLOSET                  |
| EST      | ESTIMATE (D)                          | OFF      | OFFICE                                     | WD       | WOOD                          |
| EW       | EACH WAY                              | OPNG     | OPENING                                    | WDW      | WINDOW                        |
| EXH      | EXHAUST                               | OPP      | OPPOSITE                                   | WH       | WATER RESISTIVE BARRIER       |
| EXP      | EXPANSION                             | ORD      | OVERFLOW ROOF DRAIN                        |          |                               |
| EXST     | EXISTING                              | OVHD     | OVERHEAD                                   |          |                               |
| EXT      | EXTERIOR                              |          |  |          |                               |
| <b>F</b> | FACTORY                               | <b>P</b> | PANTRY                                     |          |                               |
| FAC      | FACTORY APPLIED MEMBRANE              | PE       | PEDESTAL                                   |          |                               |
| FAM      | FURNISHED BY CONTRACTOR;              | PERF     | PERFORATED                                 |          |                               |
| FCIO     | FINISHED BY OWNER                     | PERIM    | PERIMETER                                  |          |                               |
|          |                                       | PERM     | PERMANENT                                  |          |                               |
| FD       | FLOOR DRAIN                           | PERP     | PERPENDICULAR                              |          |                               |
| FDN      | FOUNDATION                            | PL       | PROPERTY LINE                              |          |                               |
| FE       | FIRE EXTINGUISHER                     | PLAM     | PLASTIC LAMINATE                           |          |                               |
| FEP      | FINISHED END PANEL                    | PLWD     | PLYWOOD                                    |          |                               |
| FIN      | FINISH (ED)                           | PR       | PAIR                                       |          |                               |
| FL       | FLASHING                              | PRCST    | PRECAST                                    |          |                               |
| FLR      | FLOOR                                 | PREFAB   | PREFABRICATED                              |          |                               |
| FOC      | FACE OF CONCRETE                      | PRELIM   | PRELIMINARY                                |          |                               |
| FOF      | FACE OF FINISH                        | PRKG     | PARKING                                    |          |                               |
| FOM      | FACE OF MASONRY                       | PROJ     | PROJECT                                    |          |                               |
| FOS      | FACE OF STUDS                         | PROP     | PROPERTY                                   |          |                               |
| FOIA     | FURNISHED BY OWNER;                   | PSI      | POUNDS PER SQUARE INCH                     |          |                               |
| FOIC     | INSTALLED BY ARTIST                   | PT       | POST-TENSIONED, PRESSURE TREATED           |          |                               |
|          |                                       | PTD      | PAINTED                                    |          |                               |
| FPL      | FIREPLACE                             | PVMT     | PAVEMENT                                   |          |                               |
| FRT      | FIRE RETARDANT TREATED                |          |  |          |                               |
| FT       | FOOT, FEET                            |          |  |          |                               |
| FTG      | FOOTING                               |          |  |          |                               |
| FURN     | FURNITURE, FURNISHE(D)                |          |  |          |                               |

### GRAPHIC SYMBOLS

| SYMBOL | MATERIAL                         |
|--------|----------------------------------|
|        | FINISHED WOOD                    |
|        | CONTINUOUS ROUGH FRAMING         |
|        | BLOCKING                         |
|        | PLYWOOD                          |
|        | CONCRETE CAST-IN-PLACE           |
|        | GRANULAR FILL                    |
|        | EARTH                            |
|        | GLASS                            |
|        | RIGID INSULATION                 |
|        | BATT INSULATION                  |
|        | GWB                              |
|        | DRAWING NUMBER<br>SHEET NUMBER   |
|        | DRAWING NUMBER<br>SHEET NUMBER   |
|        | DRAWING NUMBER<br>SHEET NUMBER   |
|        | ELEVATION POINT OR CONTROL POINT |
|        | FLOOR TRANSITION                 |
|        | PROPERTY CORNER                  |
|        | SITE POLE LIGHT                  |
|        | ROOF SLOPE                       |
|        | SMOKE DETECTOR                   |
|        | WALL TYPE                        |
|        | WINDOW TAG                       |
|        | DOOR TAG                         |

### PROJECT DESCRIPTION

CONSTRUCT A THREE STORY WOOD FRAME BUILDING CONTAINING 7 APARTMENTS, STORAGE/GARAGES, AND AN OFFICE SPACE

### PROJECT INFORMATION

PARCEL: 71550502000  
PROPERTY LOCATION:  
9615 BRISTOL AVE SW, LAKEWOOD, WA

TOTAL PROPERTY SIZE: 6,119 SF  
(0.14 ACRES)

CURRENT ZONING: HIGH DENSITY

APPLICABLE BUILDING AND ZONING CODES:  
INTERNATIONAL BUILDING CODE (IBC), 2015  
INTERNATIONAL MECHANICAL CODE (IMC), 2015  
INTERNATIONAL PLUMBING CODE (UPC), 2015  
NATIONAL ELECTRIC CODE (NEC), 2014  
INTERNATIONAL FUEL GAS CODE (IFC), 2015  
WAC 51-50  
ICC A117.1-2009

BUILDING OCCUPANCY BY USE: R-2  
CONSTRUCTION TYPE: V-B  
FIRE SPRINKLER: NFPA 13R

BUILDING HEIGHT: 42' - 9 1/2" FT  
BUILDING FOOTPRINT: 1,974 SF

CBZ ZONING DISTRICT 54 DUJ. CURRENT LOT ACREAGE .14 X 54 DUJ = 7.56 (8) UNITS ALLOWED

ENERGY CREDIT TABLE: PER WASHINGTON STATE ENERGY CODE  
TOTAL CREDITS EQUALS 1.5 CREDITS MIN.

EFFICIENT BUILDING ENVELOPE 1A:  
PRESCRIPTIVE COMPLIANCE IS BASED ON TABLE R402.1.1 WITH THE FOLLOWING MODIFICATIONS:  
VERTICAL FENESTRATION U = 0.28  
FLOOR R-38  
SLAB ON GRADE R-10 PERIMETER AND UNDER ENTIRE SLAB BELOW GRADE SLAB R-10 PERIMETER AND UNDER ENTIRE SLAB OR COMPLIANCE BASED ON SECTION R402.1.4: REDUCE THE TOTAL UA BY 5%.

AIR LEAKAGE CONTROL AND EFFICIENT VENTILATION 2A:  
COMPLIANCE BASED ON R402.4.1.2: REDUCE THE TESTED AIR LEAKAGE TO 3.0 AIR CHANGES PER HOUR MAXIMUM AND ALL WHOLE HOUSE VENTILATION REQUIREMENTS AS DETERMINED BY SECTION M1507.3 OF THE INTERNATIONAL RESIDENTIAL CODE SHALL BE MET WITH A HIGH EFFICIENCY FAN (MAXIMUM 0.35 WATTS/CFM), NOT INTERLOCKED WITH THE FURNACE FAN. VENTILATION SYSTEMS USING A FURNACE INCLUDING AN ECM MOTOR ARE ALLOWED, PROVIDED THAT THEY ARE CONTROLLED TO OPERATE AT LOW SPEED IN VENTILATION ONLY MODE. TO QUALIFY TO CLAIM THIS CREDIT, THE BUILDING PERMIT DRAWINGS SHALL SPECIFY THE OPTION BEING SELECTED AND SHALL SPECIFY THE MAXIMUM TESTED BUILDING AIR LEAKAGE AND SHALL SHOW THE QUALIFYING VENTILATION SYSTEM.

EFFICIENT WATER HEATING 5A:  
ALL SHOWERHEAD AND KITCHEN SINK FAUCETS INSTALLED IN THE HOUSE SHALL BE RATED AT 1.75 GPM OR LESS. ALL OTHER LAVATORY FAUCETS SHALL BE RATED AT 1.0 GPM OR LESS. TO QUALIFY TO CLAIM THIS CREDIT, THE BUILDING PERMIT DRAWINGS SHALL SPECIFY THE OPTION BEING SELECTED AND SHALL SPECIFY THE MAXIMUM FLOW RATES FOR ALL SHOWERHEADS, KITCHEN SINK FAUCETS, AND OTHER LAVATORY FAUCETS.

INSULATION:  
CEILING: R-49  
WALLS: R-21  
FLOORS: R-38

BLOWER TEST DOOR  
BLOWER DOOR TESTING TO 5 ACH OR BETTER.  
PROGRAMMABLE THERMOSTAT 5-2.

### PROJECT TEAM

OWNER  
HIGH DEFINITION HOMES, LLC  
4705 LACEY BLVD SE SUITE B  
LACEY, WA 98503

CONTACT: KELLEN MAGNAN

ARCHITECT  
REVIVAL ARCHITECTURE & DESIGN  
1910 EAST 4TH AVENUE PMB #170  
OLYMPIA, WA 98506  
PHONE: (360) 528-0513

CONTACT: JOSH SNODGRASS  
JOSH@REVIVALARCHITECTS.COM

CIVIL ENGINEER  
LARSON & ASSOCIATES, INC.  
SURVEYORS, ENGINEERS & PLANNERS  
9027 PACIFIC AVE., SUITE #4  
TACOMA, WA 98444

JEFF L. CEDERHOLM, P.E.  
VICE PRESIDENT  
CELL - (253) 370-6703  
OFFICE - (253) 474-3404 EXT. 504

LANDSCAPE ARCHITECT  
BENNIS DESIGN  
2105 36TH AVE SE  
PUYALLUP, WA 98374  
PHONE (253) 350-5844

STRUCTURAL ENGINEER  
Luke Moerke, P.E.  
Exodus Engineering, Inc.  
1286 NW Maryland Ave  
Chehalis, WA 98532  
360.345.1566

MECHANICAL & PLUMBING  
Jeff Romans  
Dumaiss-Romans, Inc.  
N. 210 University Road  
Suite 100  
Spokane Valley, WA 99206  
Ph: 509-893-9646  
Fax: 509-893-9648

DEFERRED PERMITS  
FIRE ALARM

### SHEET INDEX

| CIVIL |   |
|-------|---|
| C1.0  | COVER SHEET                                 |
| C2.0  | UTILITY SYSTEM MAP                          |
| C3.0  | TESC & GRADING PLAN                         |
| C4.0  | TESC - NOTES & SPECIFICATIONS               |
| C5.0  | GRADING, PAVING & STORM PLAN                |
| C6.0  | STORMWATER - DETAILS & SPECIFICATIONS       |
| C7.0  | SANITARY & WATER - DETAILS & SPECIFICATIONS |
| C8.0  | DETAILS                                     |
| C9.0  | DETAILS                                     |
| C10.0 | OFFSITE IMPROVEMENT PLAN                    |

### LANDSCAPE / IRRIGATION

|    |                 |
|----|-----------------|
| L1 | LANDSCAPE PLAN  |
| L1 | IRRIGATION PLAN |
| L2 | IRRIGATION PLAN |

### ARCHITECTURE

|      |                                |
|------|--------------------------------|
| A0.0 | COVER SHEET                    |
| A0.1 | ACCESSIBILITY NOTES/ DETAILS   |
| A0.2 | CODE/LIFE SAFETY               |
| A0.3 | WALL ASSEMBLIES                |
| A2.0 | 1ST FLOOR PLAN                 |
| A2.1 | 2ND FLOOR PLAN                 |
| A2.2 | 3RD FLOOR PLAN                 |
| A2.3 | ROOF PLAN                      |
| A3.0 | ENLARGED UNIT A & UNIT B PLANS |
| A3.1 | ENLARGED UNIT C & UNIT D PLAN  |
| A4.0 | EXTERIOR ELEVATIONS            |
| A4.1 | EXTERIOR ELEVATION             |
| A5.0 | BUILDING SECTIONS              |
| A6.0 | DETAILS                        |
| A6.1 | DETAILS                        |
| A7.0 | DOOR/WINDOW SCHEDULE, DETAILS  |

### STRUCTURAL ENGINEERING

|      |                           |
|------|---------------------------|
| S-1  | General Notes             |
| S-2  | Foundation Plan           |
| S-3  | First Floor Shear Layout  |
| S-4  | Second Floor Framing      |
| S-5  | Second Floor Shear Layout |
| S-6  | Third Floor Framing       |
| S-7  | Third Floor Shear Layout  |
| S-8  | Roof Framing Plan         |
| S-9  | Structural Details        |
| S-10 | Structural Details        |

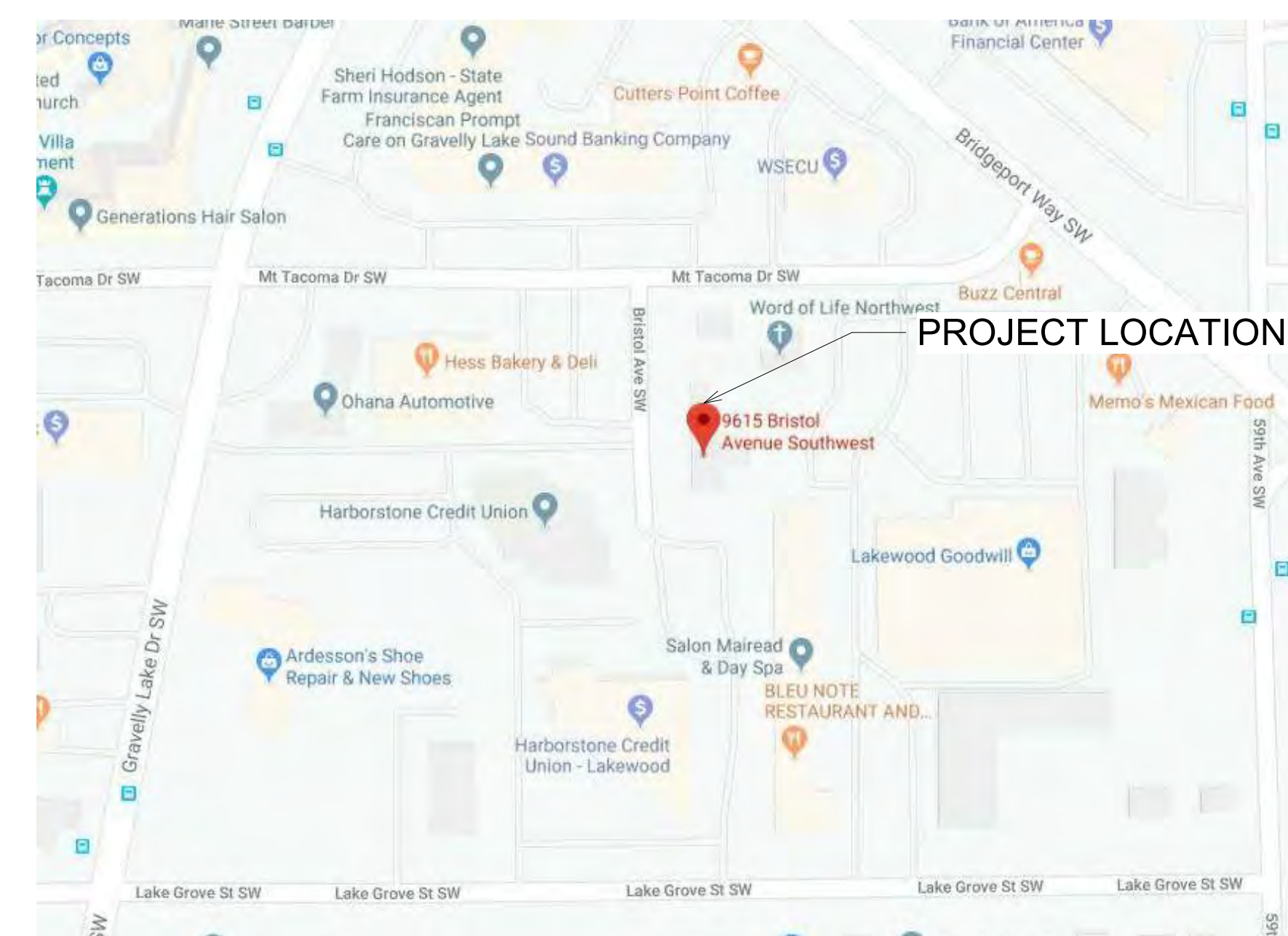

SITE MAP

BRISTOL APARTMENTS  
9615 Bristol Ave SW, Lakewood, WA

COVER SHEET

A0.0



**ACCESSIBILITY REQUIREMENTS**

THE FOLLOWING IS A SUMMARY AND IS NOT INTENDED TO PRECLUDE OR EXCLUDE ANY SECTIONS OF THE APPLICABLE CODES. THE CONTRACTOR SHALL STILL BE REQUIRED TO COMPLY WITH ALL APPLICABLE SECTIONS.

- 302.2 CARPET OR CARPET TILE SECURELY ATTACHED WITH FIRM PAD OR PAD. PILE HEIGHT MAXIMUM 1/2 INCH
- 302.3 OPENINGS- OPENINGS SHALL NOT ALLOW PASSAGE OF A SPHERE MORE THAN 1/2 INCH IN DIAMETER. ELONGATED OPENINGS MUST BE PERPENDICULAR TO DOMINANT DIRECTION OF TRAVEL.
- 302.4 CHANGES IN LEVEL OF 1/4 INCH HIGH MAXIMUM PERMITTED TO BE VERTICAL.
- 302.5 BEVELED-CHANGES IN LEVEL BETWEEN 1/4" HIGH AND 1/2" HIGH MAX BEVELED WITH SLOPE NOT STEEPER THAN 1:2
- 302.6 RAMP- CHANGES IN LEVEL GREATER THAN 1/2" HIGH SHALL BE RAMPED
- 304.1 CIRCULAR WHEELCHAIR TURNING SPACES SHALL BE 60" DIAMETER MINIMUM. KNEE AND TOE CLEARANCES MAY BE INCLUDED.
- 304.2 T-SHAPED TURNING SPACE SHALL BE 60" SQUARE MINIMUM WITH ARMS AND BASE 36" WIDE MINIMUM. EACH T ARM CLEAR OF OBSTRUCTIONS 12" MINIMUM IN EACH DIRECTION. BASE SHALL BE CLEAR OF OBSTRUCTIONS 24" MINIMUM.
- 304.3 DOORS MAY SWING INTO WHEELCHAIR TURNING SPACES.
- 304.4 CLEAR FLOOR SPACE SHALL BE 30"x48" MINIMUM AND MAY INCLUDE KNEE AND TOE CLEARANCE.
- 305.6 A FULLY UNOBSTRUCTED SIDE OF THE CLEAR FLOOR SPACE SHALL ADJOIN AN ACCESSIBLE ROUTE OR ANOTHER CLEAR SPACE.
- 305.7.1 FORWARD APPROACH-ALCOVES SHALL BE 36" WIDE MINIMUM WHEN THE DEPTH EXCEEDS 24"
- 305.7.2 PARALLEL APPROACH-ALCOVES SHALL BE 60" WIDE MINIMUM WHEN THE DEPTH EXCEEDS 15"
- 306.2 CLEARANCE-SPACE UNDER AN ELEMENT 9" ABOVE THE FINISHED FLOOR, 6" MAX DEPTH AND MINIMUM 30" WIDE
- 306.3 KNEE CLEARANCE-SPACE UNDER AN ELEMENT BETWEEN 9" AND 27" ABOVE THE FINISHED FLOOR, 25" MAXIMUM DEPTH AND 30" WIDE MINIMUM
- 308.2.1 WHERE A FORWARD REACH IS UNOBSTRUCTED, THE HIGH FORWARD REACH SHALL BE 48" MAXIMUM AND THE LOW FORWARD REACH SHALL BE 15" MINIMUM ABOVE THE FLOOR.
- 308.2.2 WHERE THE REACH DEPTH EXCEEDS 20", THE HIGH FORWARD REACH SHALL BE 44" MAX. ABOVE THE FLOOR.
- 309.1 OPERABLE PARTS REQUIRED TO BE ACCESSIBLE SHALL COMPLY WITH SECTION 309
- 309.2 A CLEAR FLOOR SPACE COMPLYING WITH SECTION 305 SHALL BE PROVIDED
- 309.3 OPERABLE PARTS SHALL BE PLACED WITHIN ONE OR MORE OF THE REACH RANGES SPECIFIED IN SECTION 308
- 309.4 OPERABLE PARTS SHALL BE OPERABLE WITH ONE HAND AND SHALL NOT REQUIRE TIGHT GRASPING, PINCHING, OR TWISTING OF THE WRIST. THE FORCE REQUIRED TO ACTIVATE OPERABLE PARTS SHALL BE 5.0 POUNDS MAXIMUM
- 309.5 PROTRUDING OBJECTS- OBJECTS MORE THAN 27" ABOVE THE FLOOR AND NOT MORE THAN 80" ABOVE THE FLOOR SHALL PROTRUDE 4" MAX HORIZONTALLY INTO THE CIRCULATION PATH
- 309.6 VERTICAL CLEARANCE 80" HIGH MINIMUM, PROVIDE GUARDRAILS OR OTHER BARRIERS 27" MAX ABOVE THE FLOOR FOR VERTICAL CLEARANCE LESS THAN 80" HIGH
- 402.2 ACCESSIBLE ROUTE COMPONENTS: WALKING SURFACE WITH RUNNING SLOPE NOT STEEPER THAN 1:20. DOORWAYS, RAMPS, CURB RAMPS, AND ELEVATORS
- 403.3 ACCESSIBLE ROUTES SHALL NOT BE STEEPER THAN 1:20 AND CROSS SLOPES SHALL BE 1:48 MAX
- 403.5 ACCESSIBLE ROUTES SHALL HAVE A CLEAR WIDTH OF 36 INCHES MINIMUM. EXCEPTION: CLEAR WIDTH MAY BE REDUCED TO 32" FOR A MAX LENGTH OF 24" WITH SUCH SEGMENTS SEPARATED BY SEGMENTS MINIMUM LONG AND 36" MINIMUM WIDE.
- 404 DOORS THAT ARE PART OF AN ACCESSIBLE ROUTE SHALL COMPLY WITH SECTION 404.
- 404.2.3 DOOR OPENINGS 32" MINIMUM CLEAR WIDTH. FOR OPENINGS MORE THAN 24" DEEP MINIMUM CLEAR WIDTH IS 36"
- 404.2.5 THRESHOLDS SHALL BE 1/2" HIGH MAXIMUM AT ACCESSIBLE DOORWAYS
- 404.2.9 DOOR OPENING FORCE-FIRE DOORS SHALL HAVE THE MINIMUM OPENING FORCE ALLOWABLE BY JURISDICTION WITH AUTHORITY. MAXIMUM FORCE FOR PUSHING OPEN ALL OTHER DOORS SHALL BE 5.0 POUNDS ((2.2 N)) FOR BOTH INTERIOR HINGED DOORS AND SLIDING OR OLDING DOORS.
- 402.10 DOOR SURFACES WITHIN 10" OF THE FINISH FLOOR SHALL HAVE A SMOOTH SURFACE ON THE PUSH SIDE EXTENDING THE FULL WIDTH OF THE DOOR.

**ACCESSIBILITY REQUIREMENTS CONT.**

- 405.2 RAMP RUNS SHALL HAVE A RUNNING SLOPE NOT STEEPER THAN 1:12
- 405.3 CROSS SLOPE OF RAMP RUNS SHALL NOT BE STEEPER THAN 1:50
- 405.5 RAMP CLEAR WIDTH BETWEEN HANDRAILS SHALL BE 36" MINIMUM
- 405.6 THE RISE FOR ANY RAMP RUN SHALL BE 30" MAXIMUM
- 405.7 RAMPS SHALL HAVE LANDINGS COMPLYING WITH 405.7 AT THE TOP AND BOTTOM OF EACH RAMP RUN
- 405.7.2 LANDING CLEAR WIDTH SHALL BE AT LEAST AS WIDE AS THE WIDEST RAMP LEADING TO THE LANDING
- 405.7.3 LANDING CLEAR LENGTH SHALL BE 60" MINIMUM
- 405.7.4 RAMPS THAT CHANGE DIRECTION BETWEEN RUNS AT LANDINGS SHALL HAVE A CLEAR LANDING 60" BY 60" MINIMUM
- 405.9 EDGE PROTECTION COMPLYING WITH 405.9.1 OR 405.9.2 IS REQUIRED ON EACH SIDE OF RAMP RUNS AND LANDINGS
- 405.9.1 FLOOR OR GROUND SURFACE OF RAMP RUN OR LANDING EXTENDING 2' MINIMUM BEYOND INSIDE FACE OF HANDRAIL
- 405.9.2 CURB OR BARRIER THAT PREVENTS PASSAGE OF A 4" DIAMETER SPHERE
- 502.2 ACCESSIBLE PARKING SPACES SHALL BE 96" WIDE MINIMUM (CAR) AND 132" WIDE MINIMUM (VAN).
- 502.4.2 ACCESS AISLES SERVING CAR PARKING SPACES SHALL BE 60" WIDE MINIMUM.
- 503.4 MAXIMUM SLOPE AT PARKING SPACES AND ACCESS AISLES SHALL BE 1:50.
- 504.3 STAIRS-OPEN RISERS NOT PERMITTED
- 505.3 STAIR HANDRAILS SHALL BE CONTINUOUS AND HAVE A MINIMUM 36" CLEARANCE BETWEEN RAILS.
- 505.4 HANDRAIL HEIGHT SHALL BE 34" MINIMUM AND 38" MAXIMUM VERTICALLY ABOVE WALKING SURFACES, STAIR NOSINGS, AND RAMPS
- 505.5 CLEARANCE BETWEEN HANDRAIL GRIPPING SURFACE AND ADJACENT SURFACES SHALL BE 1-1/2" MINIMUM
- 505.7.1 HANDRAIL GRIPPING SURFACES WITH A CIRCULAR CROSS SECTION SHALL HAVE AN OUTSIDE DIAMETER 1-1/4" MINIMUM AND 2" MAXIMUM
- 505.10.1 RAMP HANDRAILS SHALL EXTEND HORIZONTALLY 12" MINIMUM BETWEEN TOP AND BOTTOM OF RAMP RUNS
- 505.10.2 AT THE TOP OF A STAIR FLIGHT, HANDRAILS SHALL EXTEND HORIZONTALLY ABOVE THE LANDING FOR 12" MINIMUM
- 505.10.3 AT THE BOTTOM OF A STAIR FLIGHT, HANDRAILS SHALL EXTEND A HORIZONTAL DISTANCE EQUAL TO AT LEAST ONE TREAD DEPTH
- 506.1 ACCESSIBLE WINDOWS SHALL HAVE OPERABLE PARTS COMPLYING WITH SECTION 309
- 603 TOILET AND BATHING ROOMS
- 603.2.2 REQUIRED CLEAR FLOOR SPACES, CLEARANCE AT FIXTURES AND TURNING SPACE MAY OVERLAP
- 603.2.3 DOORS SHALL NOT SWING INTO THE CLEAR FLOOR SPACE REQUIRED FOR ANY FIXTURE. DOORS MAY SWING INTO REQUIRED TURNING SPACE
- 603.3 MIRRORS ABOVE COUNTERTOPS OR LAVATORIES SHALL BE INSTALLED WITH THE BOTTOM EDGE 40" MAXIMUM ABOVE THE FINISHED FLOOR
- 603.4 SHELVES SHALL BE LOCATED 40" MINIMUM AND 48" MAXIMUM ABOVE THE FINISHED FLOOR
- 604.2 CENTERLINE OF WATER CLOSETS SHALL BE 16" MINIMUM AND 18" MAXIMUM FROM A SIDE WALL OR PARTITION
- 604.3.1 CLEARANCE AROUND A WATER CLOSET SHALL BE 60" MINIMUM MEASURED PERPENDICULAR FROM THE SIDEWALL AND 56" MINIMUM MEASURED PERPENDICULAR FROM THE REAR WALL
- 604.5 GRAB BARS SHALL BE PROVIDED ON THE SIDE WALL CLOSEST TO THE WATER CLOSET AND ON THE REAR WALL
- 606.3 LAVATORIES AND SINKS SHALL BE INSTALLED WITH THE FRONT OF THE HIGHER RIM OR COUNTER SURFACE 34" MAXIMUM ABOVE THE FINISHED FLOOR
- 606.4 WATER SUPPLY AND DRAIN PIPES UNDER LAVATORIES AND SINKS SHALL BE INSULATED OR OTHERWISE CONFIGURED TO PROTECT AGAINST CONTACT
- 607.2 CLEARANCE IN FRONT OF BATHTUBS SHALL EXTEND THE LENGTH OF THE BATHTUB AND SHALL BE 30 INCHES MINIMUM WIDE
- 702.1 AUDIBLE AND VISUAL ALARMS AND NOTIFICATION APPLIANCES SHALL BE INSTALLED IN ACCORDANCE WITH NFPA 72 LISTED IN SECTIONS 105.2.2, BE POWERED BY A COMMERCIAL LIGHT AND POWER SOURCE, BE PERMANENTLY CONNECTED TO THE WIRING OF THE PREMISES ELECTRIC SYSTEM, AND BE PERMANENTLY INSTALLED.

**CHAPTER 10 - DWELLING UNITS - SEE DETAILS ON THIS SHEET**  
 1002.3.1 AN ACCESSIBLE ROUTE SHALL CONNECT ALL SPACES AND ELEMENTS THAT ARE PART OF THE UNIT  
 1002.3.2 ALL ROOMS MUST HAVE A TURNING SPACE COMPLYING WITH SECTION 304. EXCEPTION: CLOSETS 48" MAXIMUM IN DEPTH

**CLEARANCE:** MIN CLEAR WIDTH BETWEEN ALL OPPOSING COUNTERS, BASE CABINETS, COUNTERTOPS, APPLIANCES, WALLS AND HANDLES SHALL BE 40" MIN IN PASS-THROUGH KITCHENS & 60" MIN IN U-SHAPED KITCHENS PER ANSIC SEC. 1003.12.1.1 AND UFAS SEC. 4.34.6.1.

**REFRIGERATOR:** 50% MIN OF FREEZER SPACE SHALL BE BELOW 54" AFF PER ANSIC SEC. 804.6.6 AND UFAS SEC. 4.34.3.1(2a).

**CLEAR FLOOR SPACE:** 30" x 48" MIN -AT SINK - FORWARD APPROACH & CENTERED -AT DISHWASHER - ADJACENT TO DW DOOR -AT RANGE - PARALLEL APPROACH -AT WORK SURFACE - FORWARD APPROACH & CENTERED -AT REF - PARALLEL APPROACH & CENTERED

**STORAGE:** -AT LEAST ONE SHELF OF ALL CABINETS AND STORAGE ABOVE ACCESSIBLE WORK SURFACE SHALL BE MOUNTED 48" MAX AFF PER UFAS SEC. 4.34.6.1(1). -50% MIN OF KITCHEN STORAGE MUST BE WITHIN ACCESSIBLE REACH RANGES PER ANSIC SEC. 804.5

**TYPE 'B' UNITS:** -PARALLEL OR FORWARD APPROACH IS ALLOWED AT RIO, REF, AND DW IN TYPE 'B' UNITS PER ANSIC SEC. 1004.12.2 -LOWER HEIGHT ACCESSIBLE WORK SURFACE AND SINK ARE NOT REQUIRED AND SINK MAY HAVE PARALLEL APPROACH PER ANSIC SEC. 1004.12.2.1

**DISHWASHER:** -CLEAR FLOOR SPACE SHALL BE POSITIONED ADJACENT TO THE DISHWASHER DOOR AND THE OPEN DOOR SHALL NOT OBSTRUCT THE CLEAR FLOOR SPACE FOR THE DISHWASHER OR AN ADJACENT SINK PER ANSIC SEC. 804.6.3

**RANGE / OVEN:** -PROVIDE ACCESSIBLE REMOTE SWITCH FOR RANGE HOOD FAN (AND LIGHT IF APPLICABLE) -CONTROLS SHALL BE LOCATED TO PREVENT REACHING OVER BURNERS PER UFAS SEC. 4.34.6.6.1

**WORK SURFACE:** -PROVIDE A COUNTER SURFACE, 30" WIDE MIN X 24" DEEP AT 34" AFF MAX, W/ KNEE AND TOE CLEARANCES PER ANSIC SEC. 306

**IN-TYPE 'A' UNITS,** A COUNTER SPACE MUST BE ADJACENT TO THE RANGE / OVEN, HOWEVER IT IS NOT REQUIRED TO BE AN ACCESSIBLE WORK SPACE PER ANSIC SEC. 1003.12.1.5 BUT ONLY IF THE OVEN IS SELF CLEANING PER UFAS SECTION 4.34.6.6.4 & 4.34.6.7

**A REMOVABLE CABINET** MAY BE PROVIDED IN THIS LOCATION IF ALL FINISHES EXTEND THE FULL DEPTH UFAS SEC. 4.34.6.4(3)

**COUNTER AND SUPPORTING STRUCTURE** TO BE 2" THICK MAX OVER THE REQUIRED CLEAR AREA PER UFAS SEC. 4.34.6.4(3)

PLAN (FOR REFERENCE ONLY, REFER TO UNIT PLANS FOR ACTUAL KITCHEN LAYOUTS)

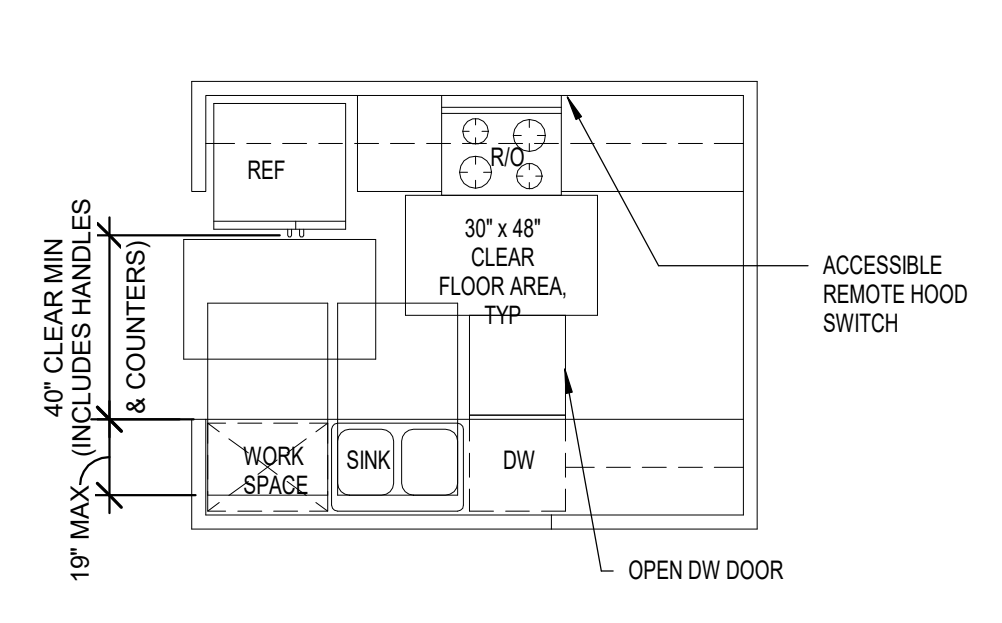

ELEVATIONS (FOR REFERENCE ONLY)

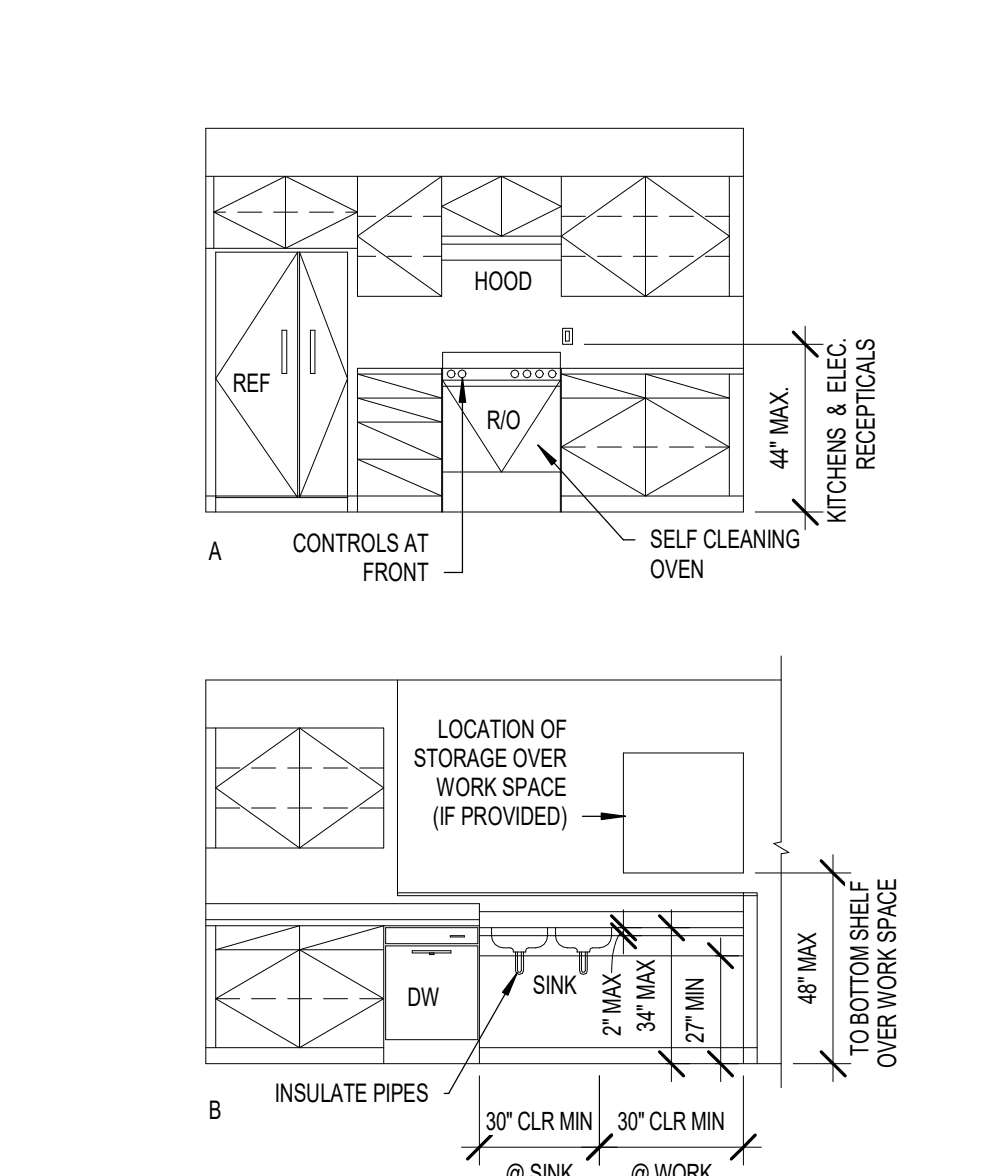

**ADA-REQUIREMENTS IN KITCHENS - TYPE 'A' & 'B'**

1/4" = 1'-0"

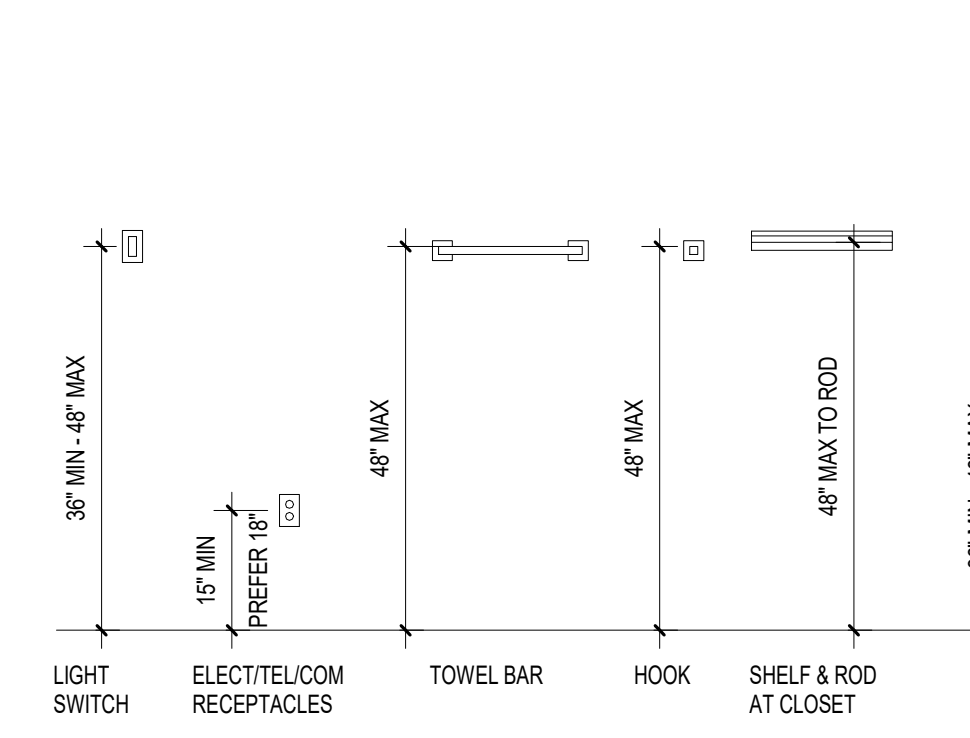

**ADA-MOUNTING HEIGHTS FOR ACCESSIBLE FIXTURES**

1/2" = 1'-0"

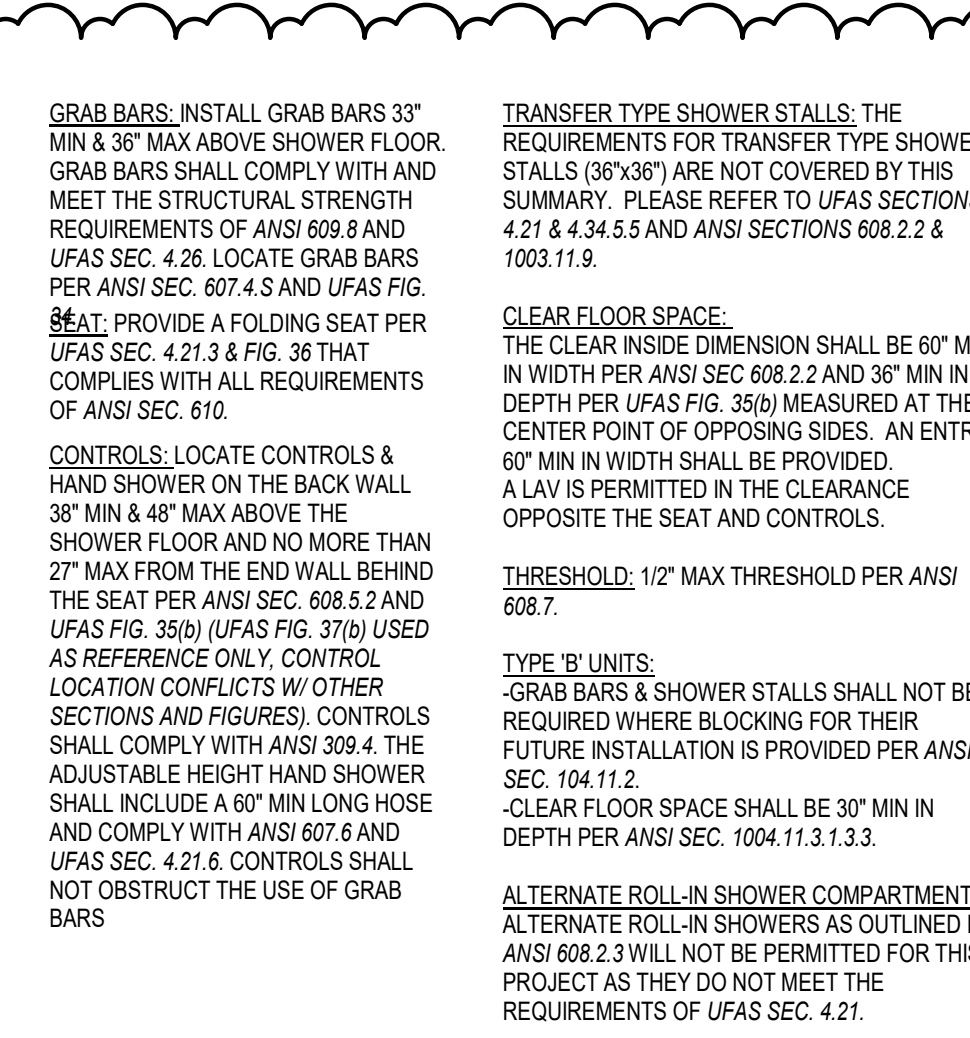

**ADA-ROLL-IN & TRANSFER SHOWER - ACCESSIBLE, TYPE 'A' & 'B'**

1/4" = 1'-0"

**ADA-BATHTUBS TYPE 'A' AND 'B'**

1/4" = 1'-0"

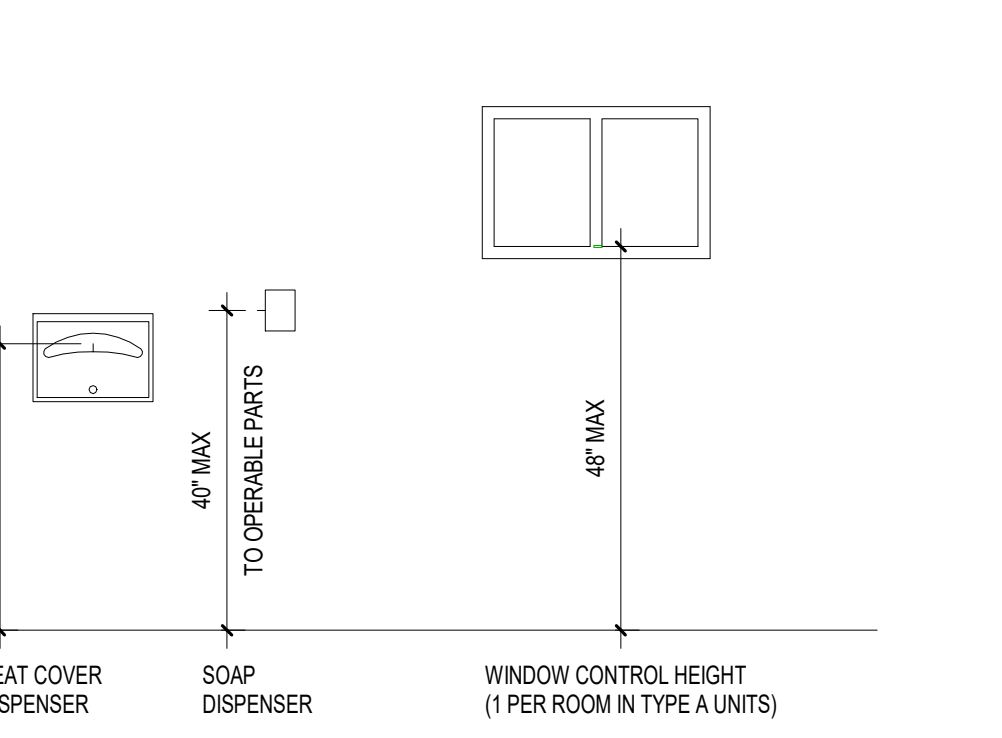

**ADA-WATER CLOSETS - TYPE 'A' & 'B'**

1/4" = 1'-0"

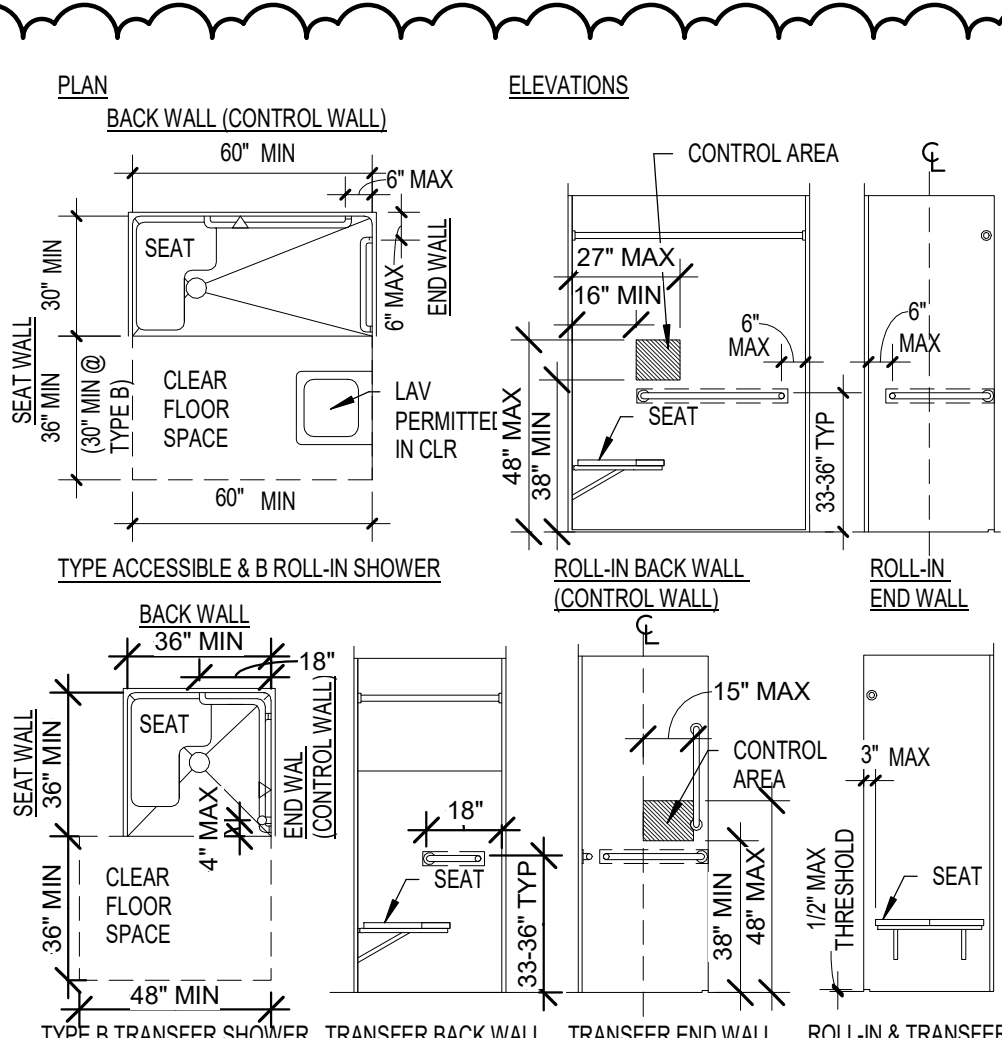

**ADA-LAVATORIES, MIRRORS, MEDICINE CABINETS & ACCESSORIES - TYPE 'A' & 'B'**

1/4" = 1'-0"

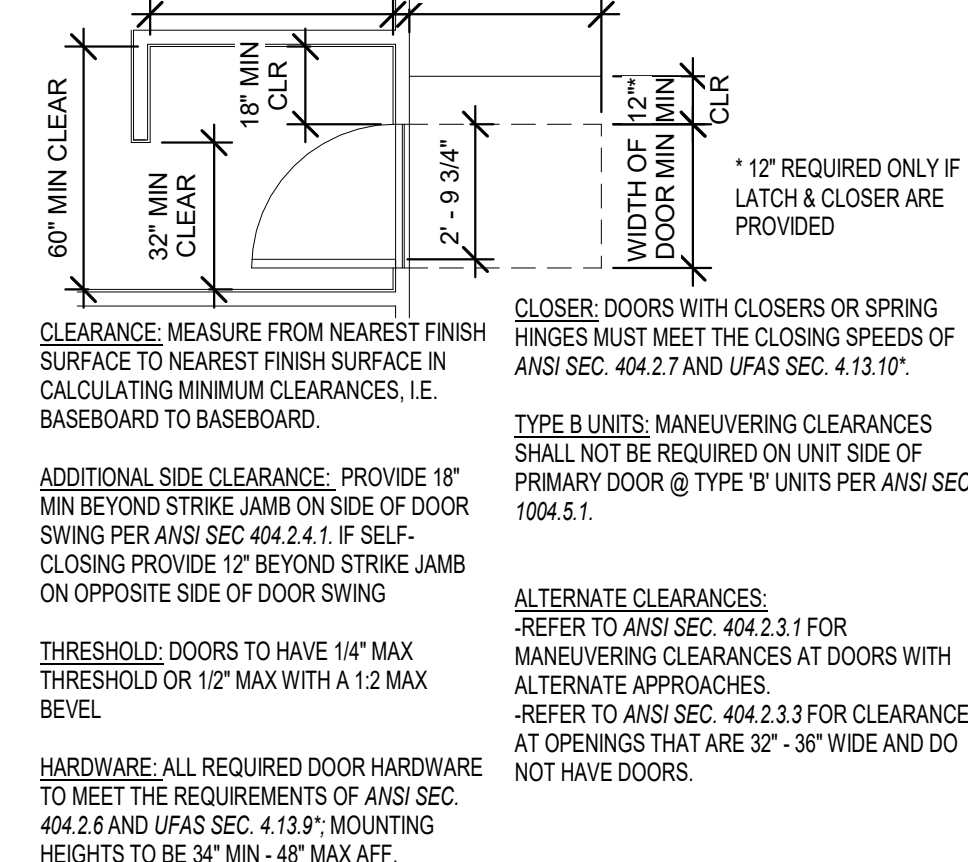

**ADA-CLEARANCES AT LAUNDRY EQUIPMENT**

1/4" = 1'-0"

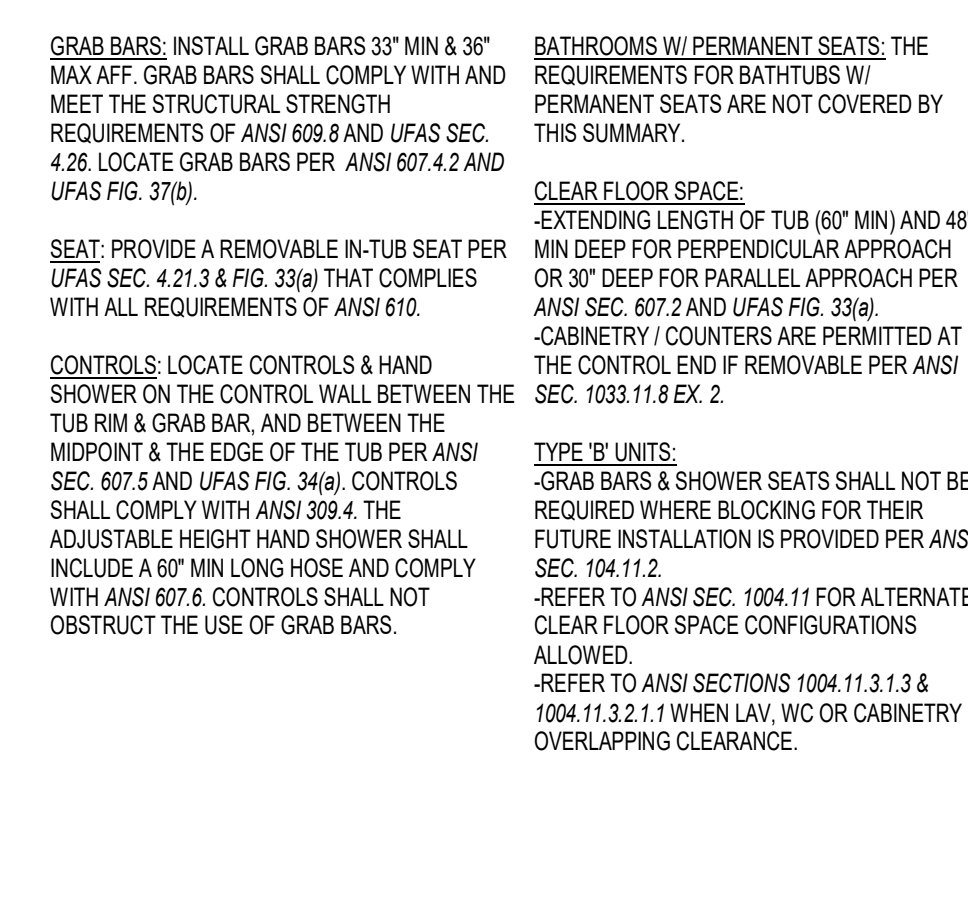

**ADA-BATHTUBS TYPE 'A' AND 'B'**

1/4" = 1'-0"

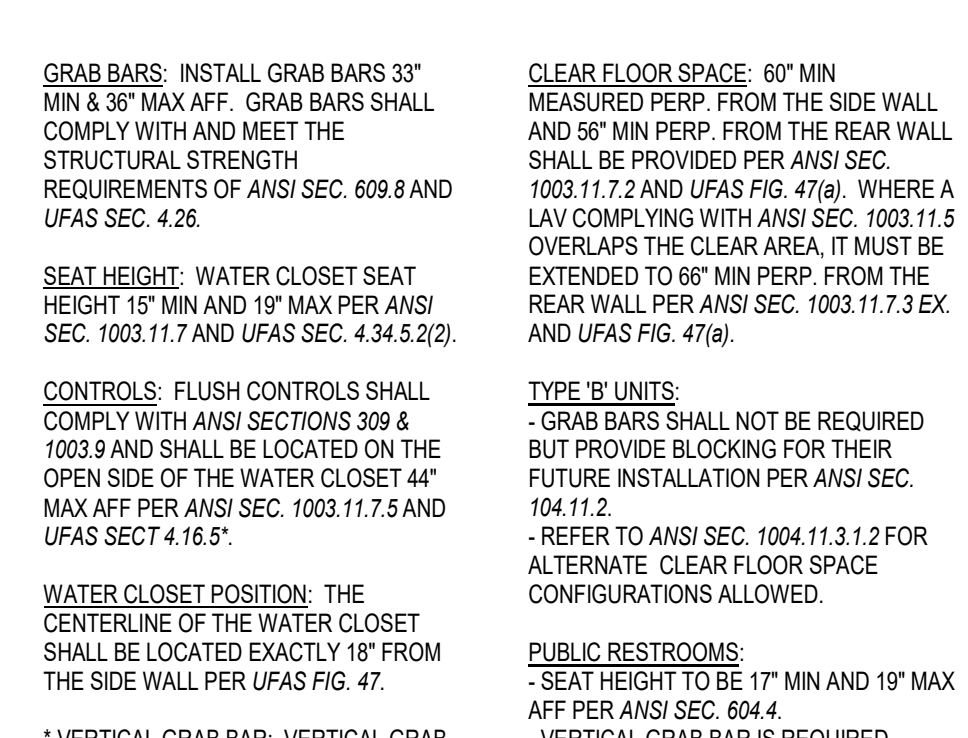

**ADA-WATER CLOSETS - TYPE 'A' & 'B'**

1/4" = 1'-0"

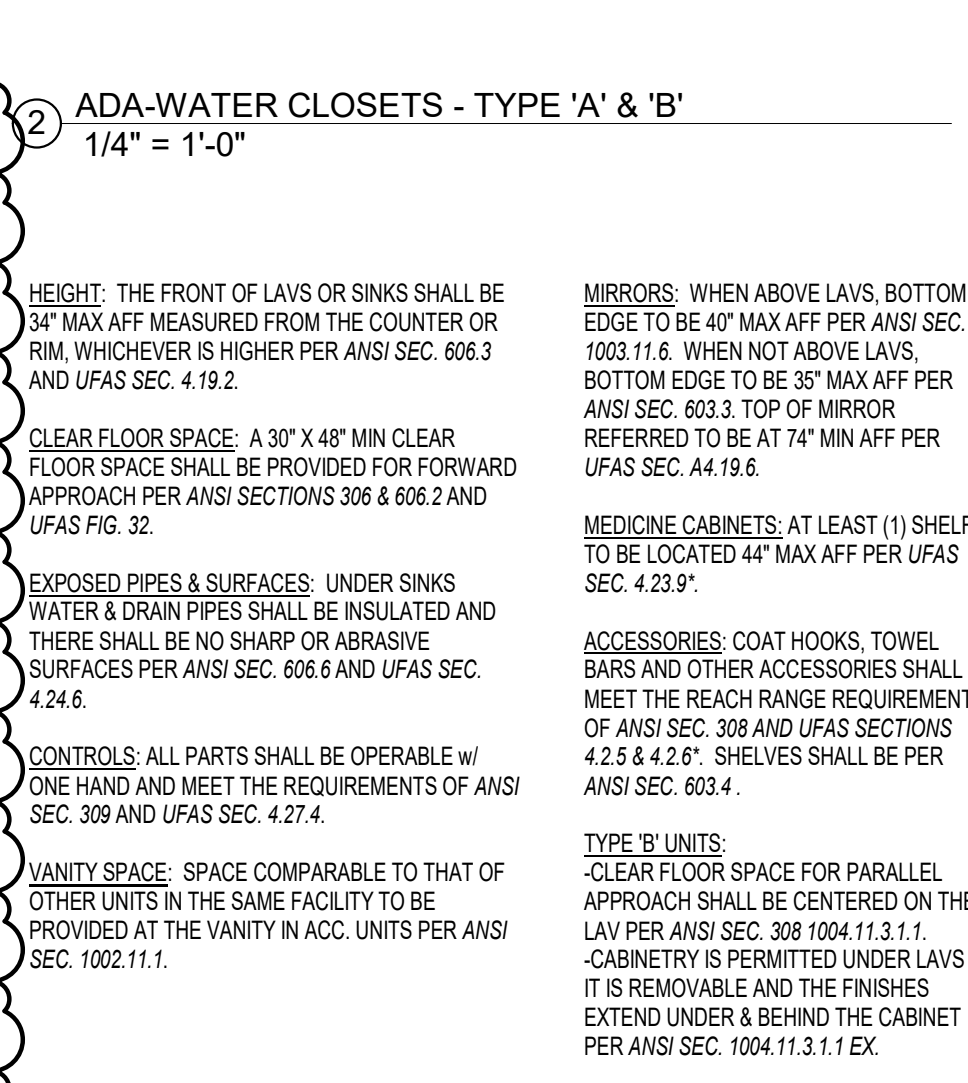

**ADA-LAVATORIES, MIRRORS, MEDICINE CABINETS & ACCESSORIES - TYPE 'A' & 'B'**

1/4" = 1'-0"

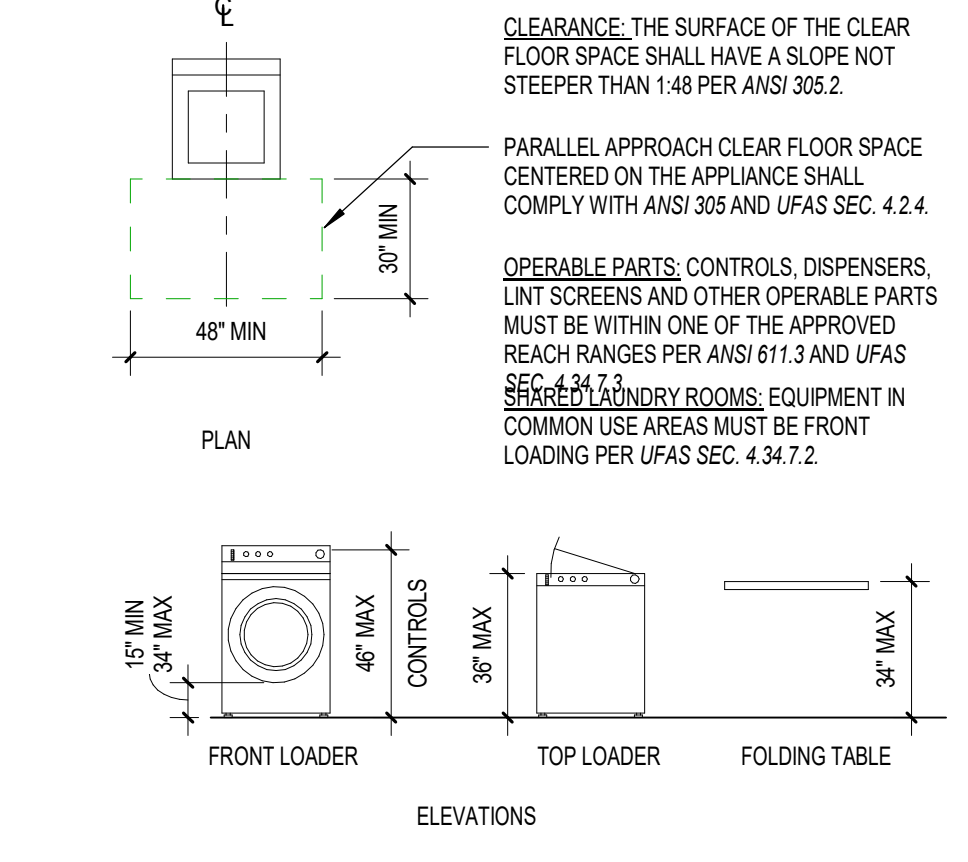

**ADA-CLEARANCES AT LAUNDRY EQUIPMENT**

1/4" = 1'-0"

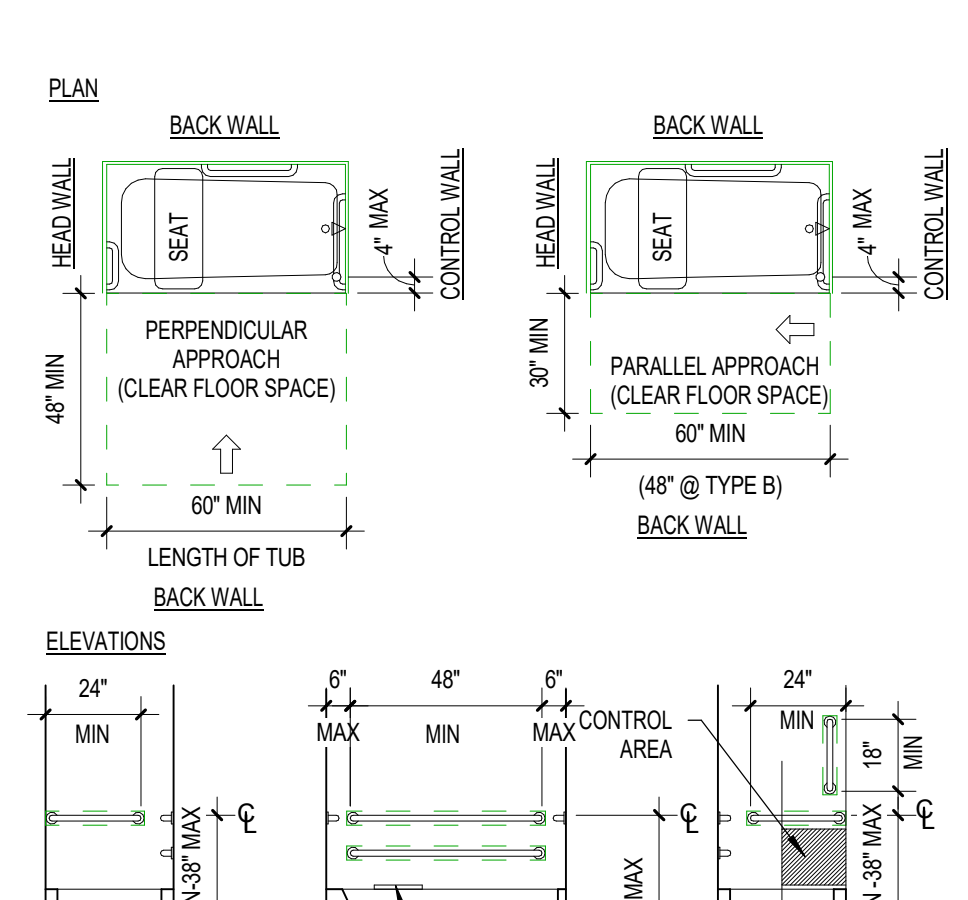

**ADA-BATHTUBS TYPE 'A' AND 'B'**

1/4" = 1'-0"

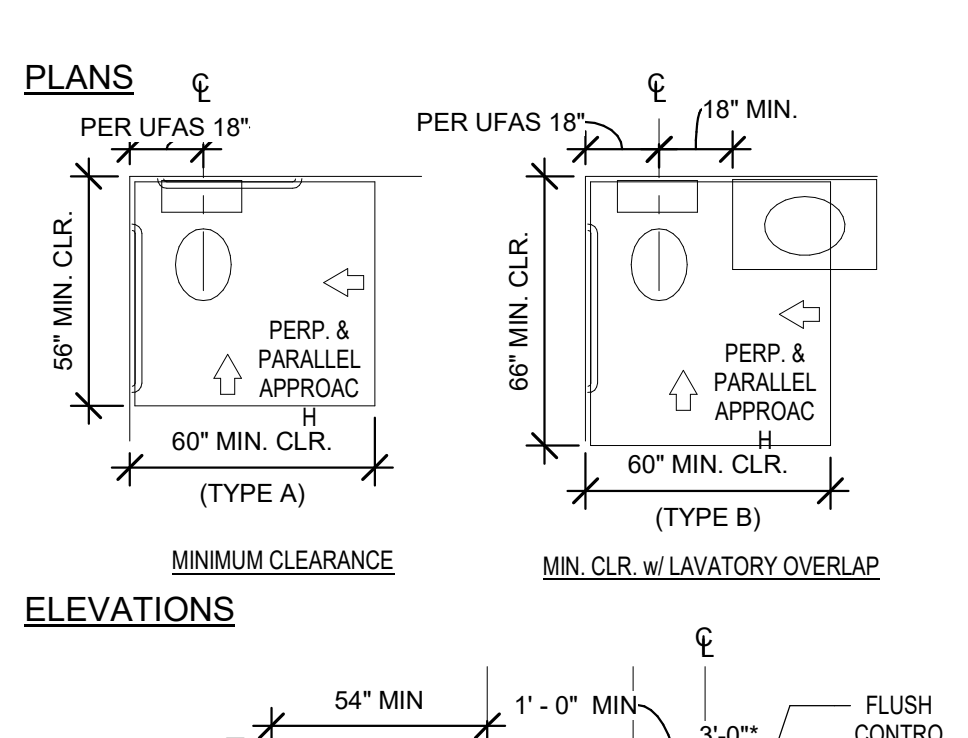

**ADA-WATER CLOSETS - TYPE 'A' & 'B'**

1/4" = 1'-0"

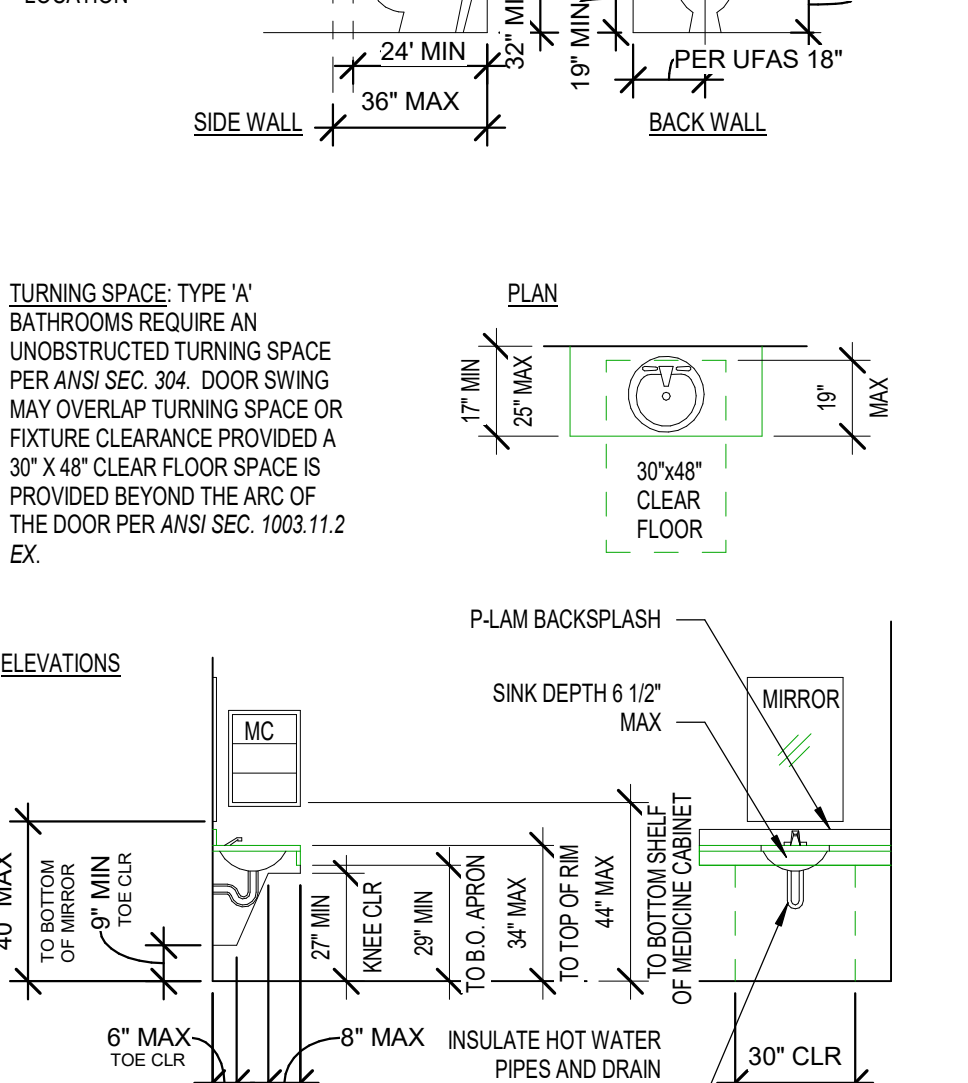

**ADA-LAVATORIES, MIRRORS, MEDICINE CABINETS & ACCESSORIES - TYPE 'A' & 'B'**

1/4" = 1'-0"

PROJ ID 643  
 PERMIT 900

RECEIVED  
 City of Lakewood



1910 EAST 4TH AVENUE PMB 9170  
 OLYMPIA, WA 98506  
 PHONE: 360-528-0513  
 JOSH@REVIVALARCHITECTS.COM

LJB DESIGNS, LLC  
 111 Market Street N.E., Suite 325  
 Olympia, Washington 98501  
 (360) 867-1945  
 E-mail: LJBDesigns@Comcast.net

**REVISIONS**

| # | ISSUED   | DATE     |
|---|----------|----------|
| 1 | 12/01/20 | 12/01/20 |



**BRISTOL APARTMENTS**  
 9615 Bristol Ave SW, Lakewood, WA

**ACCESSIBILITY NOTES/ DETAILS**

**A0.1**



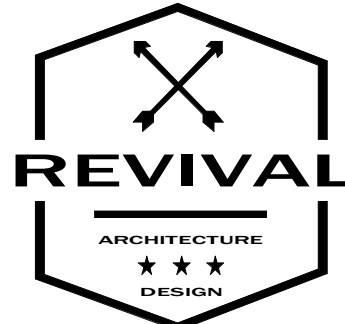

1910 EAST 4TH AVENUE PMB #170  
OLYMPIA, WA 98506  
PHONE: 360-528-0513  
JOSH@REVIVALARCHITECTS.COM

LJB DESIGNS, LLC  
111 Market Street N.E., Suite 325  
Olympia, Washington 98501  
(360) 867-1945

E-mail: LJBDesigns@Comcast.net

REVISIONS

Table with 3 columns: #, ISSUED, DATE

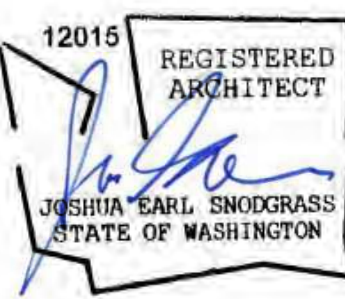

12015 REGISTERED ARCHITECT

JOSHUA EARL SMOGGRASS  
STATE OF WASHINGTON

BRISTOL APARTMENTS  
9615 Bristol Ave SW, Lakewood, WA

CODE/LIFE SAFTY

A0.2

CODE SUMMARY

PARCEL: 71550502000  
PROPERTY LOCATION:  
9615 BRISTOL AVE SW, LAKEWOOD, WA

TOTAL PROPERTY SIZE: 6,119 SF  
(0.14 ACRES)

CURRENT ZONING: HIGH DENSITY

APPLICABLE BUILDING AND ZONING CODES:  
IBC 2015 EDITION & WAC 51-50

BUILDING OCCUPANCY BY USE: R-2  
CONSTRUCTION TYPE: V-B  
FIRE SPRINKLER: NFPA 13R

AREA FACTOR INCREASE

W = (L1 x W1)/F  
W = (69.9 x 30)/69.9 = 30ft

I = (F/IP - 0.25)/W/30  
I = (69.9/254-0.25)/30/30  
I = .025

ALLOWABLE AREA MULTISTORY BUILDING PER EQUATION 5-2  
Aa = (A1 + (NS x If)) x Sa  
Aa = (71,000 + (7,000 x .025)) x 3  
Aa = 21,529  
BUILDING AREA 6,040 SF=21,529 SF

BUILDING HEIGHT: 42' - 9 1/2" FT  
BUILDING FOOTPRINT: 1,974 SF

GROSS AREAS CONDITIONED SPACES

Table with 2 columns: GROSS AREAS, CONDITIONED SPACES. Rows include FIRST FLOOR, SECOND FLOOR, THIRD FLOOR, TOTAL GROSS FLOOR AREA.

OCCUPANT LOAD  
6,040 SF / 200 SF PER OCCUPANT = 31 OCCUPANT LOAD

TABLE 1004.1.2  
MAXIMUM FLOOR AREA ALLOWANCES PER OCCUPANT  
200 SQUARE FEET PER OCCUPANT  
15 OCCUPANTS PER FLOOR  
31 OCCUPANTS TOTAL IN BUILDING

BUILDING ELEMENT

Table with 2 columns: BUILDING ELEMENT, TYPE V-B. Rows include PRIMARY STRUCTURAL FRAME, BEARING WALLS, NONBEARING WALLS AND PARTITIONS, FLOOR CONSTRUCTION AND ASSOCIATED SECONDARY MEMBERS, ROOF CONSTRUCTION AND ASSOCIATED SECONDARY MEMBERS.

PER 420.2 WALL SEPARATION REQUIRED BETWEEN DWELLING OR SLEEPING UNITS. FIRE PARTITIONS TO BE IN ACCORDANCE WITH SECTION 708

PER 420.3 HORIZONTAL SEPARATION REQUIRED BETWEEN DWELLING OR SLEEPING UNITS. FIRE PARTITIONS TO BE IN ACCORDANCE WITH SECTION 708

PER TABLE 1020 CORRIDORS TO BE RATED 1/2 HR MIN. ENTRY DOORS TO BE 20 MINUTE PER TABLE 716.5

SOUTH SIDE OF BUILDING FSD LESS THAN 10'. THEREFOR, PER TABLE 602, WALL REQUIRED TO BE 1 HOUR RATED.

PER 705.8.1 EXCEPTION 1. SOUTH SIDE BUILDING WALL PERMITTED TO HAVE UNLIMITED UNPROTECTED OPENINGS

PER 718.4.2 DRAFTSTOP REQUIRED AT ATTIC  
PER 718.4.1.1 OPENINGS IN THE PARTITIONS SHALL BE BROTECTED BY SELF CLOSING DOORS WITH AUTOMATIC LATCHES

PER 907.2.9.1 MANUAL FIRE ALARM SYSTEM NOT REQUIRED

TABLE 803.11-INTERIOR WALL AND CEILING FINISH REQUIREMENT BY OCCUPANCY

Table with 4 columns: GROUP, EXIT ENCLOSURES & EXIT PASSAGEWAYS, CORRIDORS, ROOMS AND ENCLOSED SPACES. Row for R-2 shows B, B, C.

SECTION 804 - INTERIOR FLOOR FINISH

804.2 - FLOOR FINISH AND FLOOR COVERING MATERIALS REQUIRED BY SECTION 804.4.2 SHALL BE BLOSS 1 OR II MATERIALS IN ACCORDANCE WITH NFPA 253  
CLASS 1: 0.45 WATTS/CM OR GREATER  
CLASS II: 0.22 WATT/CM OR GREATTER

804.4.2 - MINIMUM CRITICAL RADIANT FFLUX - INTERIOR FLOOR FINISHES AND FLOOR COVERING MATERIALS IN EXIT ENCLOSURES, EXIT PASSAGEWAYS, AND CORRIDORS SHALL NOT BE LESS THAN CLASS II IN OCCUPANCY GROUP R-2

SECTION 906- PORTABLE FIRE EXTINGUISHERS-THIS SECTION AND PER NFPA

906.1 - IN GROUP GROUP R-2, REQUIRED IN LOCATIONS SPECIFIED IN ITEMS 2 THROUGH 6 WHERE EACH DWELLING UNIT IS PROVIDED WITH A PORTABLE FIRE EXTINGUISHER HAVING A MIN. RATING OF 1-A:10-B-C  
2. WITHIN 30 FEET OF COMMERCIAL COOKING EQUIPMENT  
3. IN AREAS WHERE FLAMMABLE OR COMBUSTIBLE LIQUIDS ARE STORED, USED OR DISPENSED.  
4. ON EACH FLOOR OF STRUCTURES UNDER CONSTRUCTION, EXCEPT GROUP R-3 OCCUPANCIES, IN ACCORDANCE WITH SECTION 3315.1 OF THE INTERNATIONAL FIRE CODE.  
5. WHERE REQUIRED BY THE INTERNATIONAL FIRE CODE SECTIONS NDICATED IN TABLE 906.1  
6. SPECIAL-HAZARD AREAS, INCLUDING BUT NOT LIMITED TO LABORATORIES, COMPUTER ROOMS AND GENERATOR ROOMS, WHERE REQUIRED BY THE FIRE CODE OFFICIAL.

EXIT REQUIRMENTS

PER TABLE 1006.3.1 HAVE A MINIMUM OF TWO EXISTS FROM EACH STORY  
PER TABLE 1017.2 MAXIMUM EXIT ACCESS TRAVEL-250 FT WITH SPRINKLERS  
ENTRY DOORS MIN. WIDTH = 2 INCHES PER OCCUPANT

BUILDING CODE NOTES

CODE: INTERNATIONAL BUILDING CODE, 2015 EDITION & WAC 51-50  
THE FOLLOWING IS A SUMMARY AND IS NOT INTENDED TO PRECLUDE OR EXCLUDE ANY SECTIONS OF THE APPLICABLE CODES. THE CONTRACTOR SHALL STILL BE REQUIRED TO COMPLY WITH ALL APPLICABLE SECTIONS.

CHAPTER 4 - SPECIAL DETAILED REQUIREMENTS BASED ON USE AND OCCUPANCY  
420.2 SEPARATION WALLS - WALLS SEPARATING DWELLING UNITS IN THE SAME BUILDING SHALL BE CONSTRUCTED AS FIRE PARTITIONS IN ACCORDANCE WITH SECTION 709.  
420.3 HORIZONTAL SEPARATION - FLOOR ASSEMBLIES SEPARATING DWELLING UNITS IN THE SAME BUILDING SHALL BE CONSTRUCTED AS HORIZONTAL ASSEMBLIES IN ACCORDANCE WITH SECTION 711.

CHAPTER 6 - TYPES OF CONSTRUCTION  
TABLE 601 TYPE VB CONSTRUCTION (RESIDENTIAL) - STRUCTURAL FRAME, INTERIOR AND EXTERIOR BEARING WALLS, FLOOR & ROOF CONSTRUCTION ARE NOT REQUIRED TO BE FIRE-RESISTANCE RATED.

TABLE 602: WHEN THE FIRE SEPARATION DISTANCE (FSD) IS LESS THAN 10', THE EXTERIOR WALLS FOR BUILDINGS THAT ARE OCCUPANCY TYPE VB IS TO BE 1-HR MIN FIRE RATED.  
602.5 TYPE V CONSTRUCTION SHALL BE CONSTRUCTED OF ANY MATERIALS ALLOWED BY CODE.

CHAPTER 7 - FIRE-RESISTANCE-RATED CONSTRUCTION (SEE ALSO ADDITIONAL DOOR & OPENING CODE NOTES)

705.8 ALLOWABLE AREA OF OPENINGS SHALL BE PER TABLE 705.8.  
FOR FSD OF 5' TO LESS THAN 10' PROTECTED ALLOWABLE OPENING AREA = 25%  
FOR FSD OF 10' TO LESS THAN 15: UNPROTECTED, SPRINKLERED, ALLOWABLE OPENING AREA = 45%  
FOR FSD OF 15' TO LESS THAN 20: UNPROTECTED, SPRINKLERED, ALLOWABLE OPENING AREA = 75%  
FOR FSD OF 20' OR MORE: UNPROTECTED, SPRINKLERED, NO LIMIT ON OPENING AREA

705.8.3 WHERE UNPROTECTED OPENINGS ARE PERMITTED, WINDOWS AND DOORS SHALL BE CONSTRUCTED OF ANY APPROVED MATERIALS.  
705.8.5 VERTICAL SEPARATION OF OPENINGS- EXCEPTION 1: THIS SECTION DOES NOT APPLY TO BUILDINGS THAT ARE THREE STORIES OR LESS ABOVE THE GRADE PLANE.  
EXCEPTION 2: DOES NOT APPLY TO BUILDINGS EQUIPPED THROUGHOUT W/ AN AUTO SPRINKLER SYSTEM IN ACCORDANCE W/ SECTION 903.3.1.1 OR 903.3.1.2.

708.1 EXTERIOR SEPARATION WALLS AS REQUIRED BY SECTION 402.2 FOR GROUPS I-1, R-2 AND R-3  
708.3 FIRE PARTITIONS SEPARATING DWELLING UNITS SHALL HAVE A FIRE-RESISTANCE RATING OF NOT LESS THAN 1-HR.

709.4 CONTINUITY - FIRE PARTITIONS SHALL EXTEND FROM THE TOP OF THE FLOOR ASSEMBLY BELOW TO THE UNDERSIDE OF THE FLOOR OR ROOF DECK ABOVE OR TO THE FIRE-RATE HORIZONTAL ASSEMBLY ABOVE.  
711.2.4.3 HORIZONTAL ASSEMBLIES SEPARATING DWELLING UNITS IN THE SAME BUILDING SHALL BE A MINIMUM 1-HOUR FIRE-RESISTANCE RATED CONSTRUCTION.

712.1.13.2 ACCESS DOORS-ACCESS DOORS SHALL BE PERMITTED IN CEILINGS OF FIRE -RESISTANCE -RATED FLOOR/CEILING ASSEMBLIES PERMITTED BY SECTION 714.2 THROUGH 714.3.3.  
WITH ASTM E119 OR UL 263 AS HORIZONTAL ASSEMBLIES AND LABELED BY AN APPROVED AGENCY FOR SUCH PURPOSE.

714.1.1 DUCTS AND AIR TRANSFER OPENINGS-PENETRATIONS OF FIRE-RESISTANCE RATED WALLS BY DUCTS THAT ARE NOT PROTECTED WITH DAMPERS SHALL COMPLY WITH SECTIONS 714.2 THROUGH 714.3.3.  
714.2 INSTALLATION DETAILS-WHERE SLEEVES ARE USED, THEY SHALL BE SECURELY FASTENED TO THE ASSEMBLY PENETRATED.

714.3.1 THROUGH PENETRATIONS OF FIRE-RESISTANCE RATED WALLS SHALL COMPLY WITH 713.3.1.1 OR 713.3.1.2.  
714.3.1.1 FIRE-RESISTANCE-RATED ASSEMBLIES-PENETRATIONS SHALL BE INSTALLED AS TESTED IN AN APPROVED FIRE-RESISTANCE-RATED ASSEMBLY.

714.3.1.2 THROUGH - PENETRATION SYSTEM-THROUGH PENETRATIONS SHALL BE PROTECTED BY AN APPROVED PENETRATION FIRESTOP SYSTEM INSTALLED AS TESTED IN ACCORDANCE WITH ASTM E 814 OR UL 1479.  
714.3.2 MEMBRANE PENETRATIONS SHALL COMPLY WITH SECTION 713.3.1. RECESSED FIXTURES IN SHALL BE INSTALLED SO THAT FIRE-RESISTANCE WILL NOT BE REDUCED.

714.4 PENETRATIONS OF A FLOOR, FLOOR/CEILING ASSEMBLY OR THE CEILING MEMBRANE OF A ROOF/CEILING ASSEMBLY SHALL BE PROTECTED PER SECTIONS 713.4.1 THROUGH 713.4.4.  
716.5 FIRE DOOR AND SHUTTER ASSEMBLIES.  
TABLE 716.5-MINIMUM FIRE DOOR AND FIRE ASSEMBLY RATING FOR:

2 HOUR FIRE BARRIER: 1-1/2 HOURS  
1 HOUR FIRE BARRIER: 1 HOUR  
1 HOUR CORRIDOR PARTITION: 1/3 HOURS

716.5.3 FIRE DOOR SHALL BE TESTED IN ACCORDANCE TO NFPA 252 OR UL 10C WITHOUT THE HOSE STREAM TEST  
716.5.7 FIRE DOORS SHALL BE LABELED SHOWING THE NAME OF THE MANUFACTURER, THE NAME OF THE THIRD-PARTY INSPECTION AGENCY, THE FIRE PROTECTION RATING. LABELS SHALL BE PERMANENTLY AFFIXED. THE LABEL SHALL BE APPLIED AT THE FACTORY OR LOCATION WHERE FABRICATION AND ASSEMBLY ARE PERFORMED.

717.1.1 DUCTS THAT PENETRATE FIRE-RESISTANCE-RATED ASSEMBLIES WITHOUT DAMPERS SHALL COMPLY WITH THE REQUIREMENTS OF SECTIONS 714.2 THROUGH 714.3.3  
717.5.3 SHAFT ENCLOSURES THAT ARE PERMITTED TO BE PENETRATED BY DUCTS AND AIR TRANSFER OPENINGS SHALL BE PROTECTED BY WITH APPROVED FIRE AND SMOKE DAMPERS. EXCEPTION 2: GROUP R OCCUPANCIES  
EQUIPPED THROUGHOUT WITH AN AUTOMATIC SPRINKLER SYSTEM IN ACCORDANCE WITH SECTION 903.3.1.1.

SMOKE DAMPERS ARE NOT REQUIRED AT PENETRATIONS OF SHAFTS WHERE:  
2.1 KITCHEN, CLOTHES DRYER, BATH AND TOILET ROOM EXHAUST OPENINGS ARE INSTALLED WITH STEEL EXHAUST SUBDUCTS, HAVING A MINIMUM WALL THICKNESS OF 0.187 INCH (NO. 26 GAUGE)  
2.2 THE SUBDUCTS EXTEND AT LEAST 22 INCHES VERTICALLY  
2.3 AN EXHAUST FAN IS INSTALLED AT THE UPPER TERMINUS OF THE SHAFT THAT IS POWERED CONTINUOUSLY IN ACCORDANCE WITH THE PROVISIONS OF 909.11.

718.2 FIRE BLOCKS (2" NOMINAL LUMBER, 3/4" PLYWOOD, 1/2" GWB, MINERAL FIBER) SHALL BE PROVIDE IN THE FOLLOWING LOCATIONS.  
718.2.2 FIRE BLOCKS REQUIRED AT CONCEALED SPACES OF WALLS & CEILINGS: 10' INTERVALS HORIZONTALLY, AT FLOOR AND CEILING LEVELS VERTICALLY

718.2.3 FIRE BLOCKS REQUIRED AT INTERCONNECTIONS BETWEEN CONCEALED HORIZ & VERT SPACES  
718.2.5 FIRE BLOCKS REQUIRED AT OPENINGS AROUND VENTS, PIPES, DUCTS, CHIMNEYS, AT CLGS AND FLRS  
718.3.2 DRAFTS STOPS (1/2" GWB OR 3/8" PLYWOOD) SHALL BE PROVIDED IN FLOOR/CEILING ASSEMBLIES AT DEMISING WALLS BETWEEN DWELLING UNITS.

718.4.2 GROUPS R1 AND R2-DRAFTSTOPS (1/2" GWB OR 3/8" PLYWOOD) SHALL BE PROVIDED AT ATTICS IN LINE WITH DWELLING UNIT SEPARATION WALLS THAT DO NOT EXTEND TO THE UNDERSIDE OF THE ROOF SHEATHING.  
EXCEPTION 1: WHERE CORRIDOR WALLS PROVIDE A DWELLING UNIT SEPARATION DRAFTSTOPPING SHALL ONLY BE REQUIRED ABOVE ONE OF THE CORRIDOR WALLS  
EXCEPTION 2: DRAFTSTOPPING IS NOT REQUIRED IN BUILDINGS EQUIPPED THROUGHOUT WITH AN AUTOMATIC SPRINKLER SYSTEM IN ACCORDANCE WITH SECTION 903.1.1.

718.4.2 IN OCCUPANCIES IN GROUP R-2 THAT DO NOT EXCEED FOUR STORIES ABOVE GRADE PLANE, THE ATTIC SPACE SHALL BE SUBDIVIDED BY DRAFTSTOPS INTO AREAS NOT EXCEEDING 3,000 SQUARE FEET OR ABOVE EVERY TWO DWELLING UNITS, WHICHEVER IS SMALLER.  
720 INSULATION SHALL HAVE A MAX FLAME-SPREAD RATING OF 25 AND A MAX SMOKE DENSITY RATING OF 450.

721.1.1 THICKNESS OF PROTECTIVE COVERINGS -THE THICKNESS OF FIRE-RESISTANT MATERIALS REQUIRED FOR PROTECTION OF STRUCTURAL MEMBERS SHALL BE NOT LESS THAN SET FORTH IN TABLE 721.1

CHAPTER 9 - FIRE PROTECTION SYSTEMS (SEE ALSO 2006 INTERNATIONAL FIRE CODE NOTES)

903.2.8 ALL BUILDINGS WITH A GROUP R FIRE AREA SHALL BE PROVIDED WITH AN AUTOMATIC SPRINKLER SYSTEM PER SECTION 903.3.  
903.3.1.2 IN BUILDINGS OF GROUP R, UP TO AND INCLUDING FOUR STORIES IN HEIGHT, AUTOMATIC SPRINKLER SYSTEMS SHALL BE INSTALLED THROUGHOUT IN ACCORDANCE WITH NFPA 13R

903.4 THE ENTIRE AUTOMATIC SPRINKLER SYSTEM SHALL BE ELECTRICALLY SUPERVISED.  
EXCEPTION: AUTOMATIC SPRINKLER SYSTEM INSTALLED IN ACCORDANCE WITH NFPA 13R WHERE A COMMON SUPPLY MAIN IS USED TO SUPPLY BOTH DOMESTIC WATER AND THE AUTOMATIC SPRINKLER SYSTEM, AND A SEPARATE SHUTOFF VALVE FOR THE AUTOMATIC SPRINKLER SYSTEM IS NOT PROVIDED.

903.4.1 MONITORING - ALARM, SUPERVISORY, AND TROUBLE SIGNALS SHALL BE DISTINCTLY DIFFERENT AND SHALL BE AUTOMATICALLY TRANSMITTED TO AN APPROVED SUPERVISING STATION OR WHEN APPROVED BY THE FIRE CODE OFFICIAL SHALL SOUND AN AUDIBLE SIGNAL AT A CONSTANTLY ATTENDED LOCATION.  
907.2.9.1 A MANUAL FIRE ALARM SYSTEM THAT ACTIVATES THE OCCUPANT NOTIFICATION SYSTEM IN ACCORDANCE WITH SECTION 907.5 SHALL BE INSTALLED IN GROUP 2 OCCUPANCIES WHERE

3. THE BUILDING CONTAINS MORE THAN 16 DWELLING UNITS.  
EXCEPTION: 3. A FIRE ALARM SYSTEM IS NOT REQUIRED IN BUILDINGS THAT DO NOT HAVE INTERIOR CORRIDORS SERVING DWELLING UNITS AND ARE PROTECTED BY AN APPROVED AUTOMATIC SPRINKLER SYSTEM...

907.2.11.2 PROVIDE SMOKE ALARMS IN THE FOLLOWING LOCATIONS:  
1. ON THE WALL OR CEILING IN THE IMMEDIATE VICINITY OUTSIDE OF THE BEDROOM/S.  
2. IN EACH SLEEPING ROOM.  
3. IN EACH STORY WITHIN A DWELLING UNIT

907.2.11.5 ALL SMOKE ALARMS WITHIN AN INDIVIDUAL DWELLING UNIT SHALL BE INTERCONNECTED.  
907.2.11.6 SMOKE ALARMS SHALL BE HARDWIRED TO BUILDING WIRING AND SHALL BE PROVIDED W/ BATTERY BACK-UP  
907.5.2.1 AUDIBLE ALARM NOTIFICATION APPLIANCES SHALL BE PROVIDED  
907.5.2.3 IN GROUP R-2 OCCUPANCIES REQUIRED TO HAVE A FIRE ALARM SYSTEM ALL DWELLING UNITS SHALL BE PROVIDED WITH THE CAPABILITY TO SUPPORT VISIBLE ALARM NOTIFICATION APPLIANCES.

CHAPTER 10 - MEANS OF EGRESS

1003.2 CEILING HEIGHT: THE MEANS OF EGRESS SHALL HAVE A CEILING HEIGHT OF NOT LESS THAN 7 FEET 6 INCHES  
EXCEPTIONS:  
2. CEILINGS OF DWELLING UNITS AND SLEEPING UNITS WITHIN RESIDENTIAL OCCUPANCIES IN ACCORDANCE WITH SECTION 1208.2  
4. STAIR HEADROOM IN ACCORDANCE WITH SECTION 1009.2  
5. DOOR HEIGHT IN ACCORDANCE WITH SECTION 1008.1.1

1003.3.1 A BARRIER SHALL BE PROVIDED WHERE THE VERTICAL CLEARANCE IS LESS THAN 80 INCHES HIGH. THE LEADING EDGE OF THE BARRIER SHALL BE LOCATED 27" MAXIMUM ABOVE THE FLOOR.  
1004 TABLE 1004.1.1-OCCUPANT LOAD SHALL BE 200 SF GROSS PER OCCUPANT FOR RESIDENTIAL OCCUPANCIES

1009.1 ACCESSIBLE MEANS OF EGRESS REQUIRED  
1009.3 EXIT ACCESS STAIRWAYS SHALL HAVE A CLEAR WIDTH OF 48" BETWEEN HANDRAILS AND AN AREA OF REFUGE  
EXCEPTIONS: CLEAR WIDTH OF 48" AND AN AREA OF REFUGE NOT REQUIRED FOR BUILDINGS EQUIPPED THROUGHOUT WITH AN AUTOMATIC SPRINKLER SYSTEM.

1010.1 MEANS OF EGRESS DOORS SHALL HAVE A MINIMUM CLEAR OPENING WIDTH OF 32" AND A MAXIMUM SWINGING DOOR LEAF SIDE OF 48"  
EXCEPTION: MINIMUM AND MAXIMUM WIDTHS DO NOT APPLY TO DOORS NOT PART OF A REQUIRED MEANS OF EGRESS IN R-2 OCCUPANCIES

1011.1 MINIMUM STAIRWAY WIDTH SHALL BE 44"  
EXCEPTION: STAIRWAYS SERVING AN OCCUPANT LOAD OF LESS THAN 50 SHALL HAVE A WIDTH OF NOT LESS THAN 36"

1011.3 MINIMUM STAIRWAY HEADROOM CLEARANCE SHALL BE 80"  
1011.5.2 STAIR RISER HEIGHTS SHALL BE 7" MAXIMUM AND 4" MINIMUM. RECTANGULAR TREAD DEPTHS SHALL BE 11" MINIMUM

1011.6 STAIRWAY LANDINGS WIDTH AND DEPTH SHALL NOT BE LESS THAN THE WIDTH OF THE STAIRWAYS THEY SERVE.  
1011.11 STAIRS SHALL HAVE HANDRAILS ON BOTH SIDES

1014.2 HANDRAIL HEIGHT MEASURED FROM STAIR TREAD NOSING SHALL BE UNIFORM, NOT LESS THAN 34" AND NOT MORE THAN 38".  
1014.6 HANDRAIL EXTENSIONS SHALL EXTEND AT LEAST 12" HORIZONTALLY BEYOND TOP RISER AND CONTINUE TO SLOPE FOR TREAD DEPTH OF ONE TREAD BEYOND THE BOTTOM RISER.

1015.2 GUARDS REQUIRED FOR OPEN WALKING SURFACES MORE THAN 30" VERTICALLY FROM THE FLOOR OR GRADE BELOW.  
1015.3 MINIMUM HEIGHT FOR REQUIRED GUARDS IS 42"

1015.4 REQUIRED GUARDS SHALL NOT HAVE OPENINGS THAT ALLOW PASSAGE OF A SPHERE 4" IN DIAMETER PER TABLE 1017.2 MAXIMUM EXIT ACCESS TRAVEL FOR R-2 WITH SPRINKLER SYSTEM IS 250 FT.  
1020.2 MINIMUM CORRIDOR WIDTH IS 44" EXCEPTION: MIN 36" WITH OCCUPANT CAPACITY OF LESS THAN 50.  
1020.4 MAXIMUM DEAD END CORRIDOR LENGTH IS 20".  
EXCEPTION: FOR R-2 OCCUPANCY WITH AUTOMATIC SPRINKLER THROUGHOUT DEAD END CORRIDOR LENGTH SHALL NOT EXCEED 50".

CHAPTER 11 - ACCESSIBILITY - SEE SHEET A00.30 FOR ICC A117.1-2009 NOTES

1104.1 SITE ARRIVAL POINTS-AT LEAST ONE ACCESSIBLE ROUTE FROM ACCESSIBLE PARKING SPACES, ACCESSIBLE PASSENGER LOADING ZONES, PUBLIC STREETS AND SIDEWALKS, AND PUBLIC TRANSPORTATION STOPS  
1104.2 WITHIN A SITE-AT LEAST ONE ACCESSIBLE ROUTE CONNECTING ACCESSIBLE BUILDINGS, FACILITIES, ELEMENTS AND SPACES ON THE SAME SITE.

1106.1 PARKING SPACES MINIMUM NUMBER PER TABLE 1106.1-FOR 1 TO 25 TOTAL SPACES: MINIMUM 1 ACCESSIBLE SPACE.  
1106.5 VAN PARKING SPACES-ONE FOR EVERY SIX OR FRACTION OF SIX ACCESSIBLE SPACES  
1107.2 ACCESSIBLE DWELLING UNITS SHALL COMPLY WITH THE WITH THE APPLICABLE PORTIONS OF CHAPTER 10 OF ICC A117.1.

1107.6 TYPE A UNITS SHALL BE APPORTIONED IN PROPORTION TO THE NUMBER OF EACH UNIT SIZE IN THE BUILDING  
1107.6.2.1.1 AT LEAST 5% OF THE UNITS ON SITE SHALL BE A TYPE A UNIT. ALL UNITS ON SITE SHALL BE CONSIDERED TO DETERMINE THE TOTAL NUMBER OF UNITS AND THE REQUIRED NUMBER OF TYPE A UNITS:  
5% OF 13 UNITS = 1 TYPE A UNITS.

1107.6.2.1.2 ALL OTHER UNITS SHALL BE TYPE B UNITS.  
1107.7.1 WHERE NO ELEVATOR SERVICE IS PROVIDED IN A STRUCTURE ONLY UNITS LOCATED ON A STORY WITH A BUILDING ENTRANCE ARE REQUIRED TO TYPE B.

1108.1 EACH TOILET ROOM SHALL BE ACCESSIBLE.  
1110.1 PROVIDE SIGNAGE WITH THE INTERNATIONAL SYMBOL OF ACCESSIBILITY:  
AT ALL ACCESSIBLE PARKING SPACES EXCEPT WHEN THE NUMBER OF SPACES PROVIDED IS FOUR OR LESS, AND AT ACCESSIBLE ENTRANCES, AND AT UNISEX TOILET ROOMS.

CHAPTER 12 - INTERIOR ENVIRONMENT

1203.2 VENTILATION OF ATTIC SPACES REQUIRED  
1203.2.1 SCREENING OF ATTIC VENTILATION OPENINGS REQUIRED  
1205.2 MINIMUM NET GLAZING AREA SHALL NOT BE LESS THAN 8 PERCENT OF THE FLOOR AREA SERVED.

1207.2 SOUND TRANSMISSION CONTROL - WALLS, PARTITIONS, AND FLOOR/CEILING ASSEMBLIES SEPARATING DWELLING UNITS FOR EACH OTHER AND FROM PUBLIC OR SERVICE AREAS SHALL HAVE AN STC OF NOT LESS THAN 50.  
1208.1 HABITABLE ROOMS OTHER THAN A KITCHEN SHALL HAVE A MINIMUM DIMENSION OF 7'-0" IN ANY DIRECTION.  
1208.2 MINIMUM CEILING HEIGHT SHALL BE 7'-6".

1208.3 EACH DWELLING UNIT SHALL HAVE AT LEAST ONE ROOM THAT IS 120 SF MINIMUM. OTHER HABITABLE ROOMS SHALL BE 70 SF MINIMUM. EXCEPTION: KITCHENS  
1210.1 FLOORS AND WALL BASE FINISH MATERIALS IN TOILET ROOMS NOT IN DWELLING UNITS SHALL HAVE A SMOOTH HARD NONABSORBENT SURFACE.

1210.2 WALLS AND PARTITIONS WITHIN 2' OF WATER CLOSETS SHALL HAVE A SMOOTH HARD NON ABSORBENT SURFACE.  
EXCEPTIONS: DWELLING UNITS AND TOILET ROOMS NOT ACCESSIBLE TO THE PUBLIC WHICH HAVE NOT MORE THAN ONE WATER CLOSET  
1210.3 WALLS AROUND SHOWERS SHALL BE FINISHED WITH A SMOOTH, NONABSORBENT SURFACE TO A HEIGHT NOT LESS THAN 70" ABOVE THE DRAIN INLET.

CHAPTER 14 - EXTERIOR WALLS

1406.3 BALCONIES- EXCEPTION 3: BALCONIES ON TYPE V BUILDINGS SHALL NOT BE REQUIRED TO HAVE A FIRE RESISTANCE RATING WHERE SPRINKLER PROTECTION IS EXTENDED TO THESE AREAS.  
EXCEPTION 4: WHERE SPRINKLER PROTECTION IS EXTENDED TO BALCONY AREAS, THE AGGREGATE LENGTH OF THE BALCONY ON EACH FLOOR SHALL NOT BE LIMITED.

CHAPTER 15 - ROOF ASSEMBLIES AND ROOFTOP STRUCTURES

TABLE 1505.1 REQUIRED: CLASS B ROOFING

CHAPTER 23 - WOOD

2304.11.2.2 WOOD FRAMING MEMBERS, INCLUDING WOOD SHEATHING, THAT REST ON EXTERIOR FOUNDATION WALLS AND ARE LESS THAN 8" FROM EXPOSED EARTH SHALL BE OF NATURALLY DURABLE OR PRESERVATIVE TREATED WOOD.CHAPTER 24 - GLAZING

2406.3 SAFETY GLAZING REQUIRED AT THE FOLLOWING HAZARDOUS LOCATIONS:  
EACH LITE OF SAFETY GLAZING SHALL BE IDENTIFIED BY A LABEL.  
1. SWINGING DOORS  
2. FIXED AND SLIDING PANELS OF SLIDING GLASS DOORS  
3. BATH AND TUB ENCLOSURES  
4. GLAZING WITHIN 24" OF DOORS WHERE BOT. EDGE OF GLAZING < 60" AFF  
5. GLAZING PANEL > 9 SF, BOTTOM<18" AFF, TOP> 36" AFF  
6. GLAZING IN RAILINGS REGARDLESS OF HEIGHT ABOVE A WALKING SURFACE  
7. GLAZING IN WALLS AT STAIRWAY LANDINGS < 60" AFF FT





1910 EAST 4TH AVENUE PMB #170  
OLYMPIA, WA 98506  
PHONE: 360-528-0513  
JOSH@REVIVALARCHITECTS.COM

12015 REGISTERED ARCHITECT  
JOSHUA EARL SMOODGRASS  
STATE OF WASHINGTON

12015 REGISTERED ARCHITECT  
JOSHUA EARL SMOODGRASS  
STATE OF WASHINGTON

## WALL ASSEMBLIES

NOTE: ALL NOTED NAILING REQUIREMENTS ARE MINIMUM AND ARE FOR MINIMUM FIRE RATINGS. SEE STRUCTURAL FOR ADDITIONAL REQUIREMENTS.

| TYPE                    | DESCRIPTION   | RATING SOURCE  | SOUND RATING |
|-------------------------|---|--|--------------|
| W4<br>TYP INTERIOR WALL | <p>INTERIOR SIDE</p> <p>PLYWOOD SHEATHING WHERE REQUIRED PER STRUCTURAL</p> <p>2 5/8" TYPE "X" GWB EACH SIDE (PROVIDE WATER RESISTANT GWB AT ALL WET WALLS)</p> <p>1 2X4 WOOD FRAMING</p> <p>NOTE: WRAP ALL PLUMBING W/SOUND INSULATION TYP AND FILL ENTIRE CAVITY WITH INSULATION.</p> | GA 3510<br>2 X 4 WALLS, TYP.<br>2 X 6 BEHIND LAUNDRY | 35-30 STC    |

| TYPE                 | DESCRIPTION  | RATING SOURCE           | SOUND RATING |
|----------------------|--|-------------------------|--------------|
| W2<br>TYP PARTY WALL | <p>DWELLING UNIT</p> <p>4 (1) LAYER 5/8" TYPE "X" GWB</p> <p>5 MIN. 3 1/2" MINERAL FIBER INSULATION</p> <p>1 2x6 WOOD FRAMING @ 16" OC UNO PER STRUCTURAL</p> <p>DWELLING UNIT</p> <p>2 1/2" RESILIENT CHANNEL @ 16" OR 24" OC</p> <p>3 (1) LAYER 5/8" TYPE "X" GWB (PROVIDE WATER RESISTANT GWB AT ALL WET WALLS)</p> <p>PENETRATIONS SHALL COMPLY WITH IBC SECTION 713.</p> <p>SEE SHEET A0.3 FOR FULL DESCRIPTION</p> | GA FILE WP 3243<br>1 HR | 50-54 STC    |

| TYPE                        | DESCRIPTION  | RATING SOURCE | SOUND RATING |
|-----------------------------|--|---------------|--------------|
| W1<br>TYPICAL EXTERIOR WALL | <p>NOTE: PROVIDE ADDITIONAL GWB LAYER WHERE REQUIRED TO ALIGN WITH INTERIOR WALLS</p> <p>EXTERIOR SIDE</p> <p>6 SIDING OVER WEATHER RESISTIVE BARRIER</p> <p>5 7/16" OSB SHEATHING UNO PER STRUCTURAL</p> <p>1 2x6 WOOD STUD FRAMING PER STRUCTURAL</p> <p>4 R-21 BATT INSULATION</p> <p>INTERIOR SIDE</p> <p>2 5/8" GWB TYPE "X" APPLY W/6D COATED NAILS, 1-7/8" LONG, .0915" SHANK, 1/4" HEAD, 7" OC LOAD BEARING</p> <p>SEE SHEET A0.3 FOR FULL DESCRIPTION</p> | UL U356       |              |

- 1 2X4 WOOD FRAMING AT 16" OR 24" O.C. UNLESS OTHER WISE NOTED BY STRUCTURAL ENGINEER.
  - 2 ONE LAYER 5/8" TYPE X GYPSUM WALLBOARD APPLIED PARALLEL OR AT RIGHT ANGLES TO EACH SIDE OF WOOD FRAMING STUDS 24" O.C. WITH 6D COATED NAILS, 1 7/8" LONG, .0915 SHANK, 1/4" HEADS, 7" O.C.
- JOINTS STAGGERED 24" ON OPPOSITE SIDES AT LOADING BEARING WALLS

- 1 2X6 WOOD FRAMING AT 16" O.C. UNLESS OTHER WISE NOTED BY STRUCTURAL ENGINEER.
- 2 RESILIENT CHANNELS 24" O.C. ATTACHED AT RIGHT ANGLES TO ONE SIDE OF THE 2X4 WOOD STUDS 16" OR 24" O.C. WITH 1 1/4" TYPE S DRYWALL SCREWS.
- 3 ONE LAYER 5/8" PROPRIETARY TYPE X GYPSUM WALLBOARD APPLIED TO CHANNELS WITH 1" TYPE S DRYWALL SCREWS AT 12" O.C..
- 4 OPPOSITE SIDE: ONE LAYER 5/8" PROPRIETARY TYPE X GYPSUM WALL BOARD OR GYPSUM VENEER BASE APPLIED AT RIGHT ANGLES TO STUDS WITH 1 1/4" TYPE W DRYWALL SCREWS 12" O.C.
- 5 VERTICAL JOINTS STAGGERED 48" ON OPPOSITE SIDES. SOUNDS TESTED WITH TUDS 16" OC.C. AND OPEN FACE OF MINERAL FIBER INSULATION BLANKETS TOWARD RESILIENT CHANNEL-SIDE OF STUD SPACE.

- 1 WOOD STUDS — NOM 2 BY 4 IN. SPACED 16 IN. OC WITH TWO 2 BY 4 IN. TOP AND ONE 2 BY 4 IN. BOTTOM PLATES. STUDS LATERALLY-BRACED BY WOOD STRUCTURAL PANEL SHEATHING (ITEM 5). WHEN MINERAL AND FIBER BOARDS\* (ITEM 5A) ARE CONSIDERED AS BRACING FOR THE STUDS, THE LOAD IS RESTRICTED TO 76% OF ALLOWABLE AXIAL LOAD. WALLS EFFECTIVELY FIRE STOPPED AT TOP AND BOTTOM OF WALL.
- 2 GYPSUM BOARD\* — ANY 5/8 IN. THICK UL CLASSIFIED GYPSUM BOARD THAT IS ELIGIBLE FOR USE IN DESIGN NOS. L501, G512 OR U305. NOM 5/8 IN. THICK, 4 FT WIDE, APPLIED VERTICALLY AND NAILED TO STUDS AND BEARING PLATES 7 IN. OC WITH 6D CEMENT-COATED NAILS, 1-7/8 IN. LONG WITH 1/4 IN. DIAM HEAD.
- \*\*\*WHEN ITEM 7, 7B, 7C, 7D OR 7E STEEL FRAMING MEMBERS\*, IS USED, GYPSUM PANELS ATTACHED TO FURRING CHANNELS WITH 1 IN. LONG TYPE S BUGLE-HEAD STEEL SCREWS SPACED 12 IN. OC.
- \*\*\*WHEN ITEM 7A STEEL FRAMING MEMBERS\*, IS USED, TWO LAYERS OF GYPSUM PANELS ATTACHED TO FURRING CHANNELS. BASE LAYER ATTACHED TO FURRING CHANNELS WITH 1 IN. LONG TYPE S BUGLE-HEAD STEEL SCREWS SPACED 12 IN. OC. FACE LAYER ATTACHED TO FURRING CHANNELS WITH 1-5/8 IN. LONG TYPE S BUGLE-HEAD STEEL SCREWS SPACED 12 IN. OC. ALL JOINTS IN FACE LAYERS STAGGERED WITH JOINTS IN BASE LAYERS.
- 3 JOINTS AND FASTENER HEADS — (NOT SHOWN) — GYPSUM BOARD JOINTS COVERED WITH TAPE AND JOINT COMPOUND, FASTENER HEADS COVERED WITH JOINT COMPOUND.
- 4 BATTS AND BLANKETS\* — MINERAL FIBER OR GLASS FIBER INSULATION, 3-1/2 IN. THICK. PRESSURE FIT TO FILL WALL CAVITIES BETWEEN STUDS AND PLATES. MINERAL FIBER INSULATION TO BE UNFACED AND TO HAVE A MIN DENSITY OF 3 PCF. GLASS FIBER INSULATION TO BE FACED WITH ALUMINUM FOIL OR KRAFT PAPER AND TO HAVE A MIN DENSITY OF 0.9 PCF (MIN R-13 THERMAL INSULATION RATING).
- SEE BATTS AND BLANKETS\* (BKNV) CATEGORY IN THE BUILDING MATERIALS DIRECTORY AND BATTS AND BLANKETS\* (BZJZ) CATEGORY IN THE FIRE RESISTANCE DIRECTORY FOR NAMES OF CLASSIFIED COMPANIES.
- 5 WOOD STRUCTURAL PANEL SHEATHING — MIN 7/16 IN. THICK, 4 FT WIDE WOOD STRUCTURAL PANELS, MIN GRADE "C-D" OR "SHEATHING". INSTALLED WITH LONG DIMENSION OF SHEET (STRENGTH AXIS) OR FACE GRAIN OF PLYWOOD PARALLEL WITH OR PERPENDICULAR TO STUDS. VERTICAL JOINTS CENTERED ON STUDS. HORIZONTAL JOINTS BACKED WITH NOM 2 BY 4 IN. WOOD BLOCKING. ATTACHED TO STUDS ON EXTERIOR SIDE OF WALL WITH 6D CEMENT COATED BOX NAILS SPACED 6 IN. OC AT PERIMETER OF PANELS AND 12 IN. OC ALONG INTERIOR STUDS.
- 6 EXTERIOR FACINGS — INSTALLED IN ACCORDANCE WITH THE MANUFACTURER'S INSTALLATION INSTRUCTIONS. ONE OF THE FOLLOWING EXTERIOR FACINGS IS TO BE APPLIED OVER THE SHEATHING:

**PROPRIETARY GYPSUM BOARD**

|   |   |
|---|---|
| American Gypsum Company                   | 5/8" FIREBLOC TYPE C                                |
| CertainTeed Gypsum, Inc.                  | 5/8" ProRoc™ Type C Gypsum Panels                   |
| G-P Gypsum                                | 5/8" ToughRock® Fireguard® C                        |
| Lafarge North America Inc.                | 5/8" Firecheck® Type C                              |
| National Gypsum Company                   | 5/8" Gold Bond® Brand FIRE-SHIELD™ Gypsum Wallboard |
| PABCO Gypsum                              | 1/2" FLAME CURB® Super "C"                          |
| Temple-Inland Forest Products Corporation | 5/8" TG-C   |

†Contact the manufacturer for more detailed information on proprietary products.

|                 |   |
|-----------------|---|
| Thickness:      | 5 3/8"  |
| Approx. Weight: | 7 psf   |
| Fire Test:      | Based on UL R3660-7, 11-12-87; UL R2717-61, 6-16-87; UL R7034, 10-24-90; UL Design U311 |
| Sound Test:     | Estimated   |

718.4.2 GROUPS R-1 AND R-2. DRAFTSTOPPING SHALL BE PROVIDED IN ATTICS, MANSARDS, OVERHANGS OR OTHER CONCEALED ROOF SPACES OF GROUP R-2 BUILDINGS WITH THREE OR MORE DWELLING UNITS AND IN ALL GROUP R-1 BUILDINGS. DRAFTSTOP-PING SHALL BE INSTALLED ABOVE, AND IN LINE WITH, SLEEPING UNIT AND DWELLING UNIT SEPARATION WALLS THAT DO NOT EXTEND TO THE UNDERSIDE OF THE ROOF SHEATHING ABOVE.

- EXCEPTIONS:**
- WHERE CORRIDOR WALLS PROVIDE A SLEEPING UNIT OR DWELLING UNIT SEPARATION, DRAFTSTOPPING SHALL ONLY BE REQUIRED ABOVE ONE OF THE CORRIDOR WALLS.
  - DRAFTSTOPPING IS NOT REQUIRED IN BUILDINGS EQUIPPED THROUGHOUT WITH AN AUTOMATIC SPRINKLER SYSTEM IN ACCORDANCE WITH SECTION 903.3.1.1.
  - IN OCCUPANCIES IN GROUP R-2 THAT DO NOT EXCEED FOUR STORIES ABOVE GRADE PLANE, THE ATTIC SPACE SHALL BE SUBDIVIDED BY DRAFTSTOPS INTO AREAS NOT EXCEEDING 3,000 SQUARE FEET (279 M<sup>2</sup>) OR ABOVE EVERY TWO DWELLING UNITS, WHICHEVER IS SMALLER.
  - DRAFTSTOPPING IS NOT REQUIRED IN BUILDINGS EQUIPPED THROUGHOUT WITH AN AUTOMATIC SPRINKLER SYSTEM IN ACCORDANCE WITH SECTION 903.3.1.2, PROVIDED THAT AUTOMATIC SPRINKLERS ARE INSTALLED IN THE COMBUSTIBLE CONCEALED SPACE WHERE THE DRAFTSTOP-PING IS BEING OMITTED.

|   | DESCRIPTION   | FIRE RATING     |
|---|---|-----------------|
| F1<br>TYPICAL FLOOR-CEILING SEPARATING APARTMENTS<br>UL L502<br>GA 5105 | <p>1" PROPRIETARY GYPSUM BOARD</p> <p>FLOOR LEVEL</p> <p>19/32" PLYWOOD</p> <p>WOOD JOISTS PER STRUCTURAL</p> <p>3-1/2" SOUND BATT INSULATION</p> <p>RESILIENT CHANNEL @ 16" O.C. WITH 6D COMMON NAILS</p> <p>STC RATING - 55-59</p> <p>(2) LAYERS 1/2" TYPE "X" GWB APPLIED AT RIGHT ANGLES TO RESILIENT FURRING 24" O.C. WITH 1" TYPE S DRYWALL SCREWS 12" O.C.</p>   | 1 HR            |
| S1<br>TYPICAL SLAB @ HEATED SPACE                                       | <p>FINISH FLOOR PER PLANS</p> <p>FLOOR LEVEL</p> <p>CONCRETE SLAB PER STRUCTURAL</p> <p>10 MIL VAPOR BARRIER</p> <p>STRUCTURAL FILL PER SOILS REPORT</p> <p>DRAIN PIPE WHERE OCCURS</p> <p>COMPACTED FILL OR STRUCTURAL FILL</p>  |                 |
| R1<br>TYPICAL CEILING @ HEATED SPACE                                    | <p>ASPHALT COMPOSITION SHINGLES (CLASS B) OVER WEATHER RESISTIVE BARRIER UNDERLAYMENT MIN 4:12 SLOPE (MAY BE AS SHALLOW AS 2:12 WITH (2) LAYERS UNDERLAYMENT PER IBC 2009 SECTION 1507.2.8)</p> <p>7/16 PLYWOOD SHEATHING</p> <p>PRE-MANUFACTURED ROOF TRUSSES (24" OC MAX)</p> <p>R-49 BATT INSULATION</p> <p>VAPOR BARRIER ON WARM SIDE</p> <p>(2) LAYERS TYPE "X" 5/8" GWB</p>                                       | GA#2602<br>1 HR |
| R2<br>TYPICAL CEILING @ EXTERIOR  | <p>ASPHALT COMPOSITION SHINGLES (CLASS B) OVER WEATHER RESISTIVE BARRIER UNDERLAYMENT MIN 4:12 SLOPE (MAY BE AS SHALLOW AS 2:12 WITH (2) LAYERS UNDERLAYMENT PER IBC 2009 SECTION 1507.2.8)</p> <p>7/16 PLYWOOD SHEATHING</p> <p>PRE-MANUFACTURED ROOF TRUSSES (24" OC MAX)</p> <p>R-49 BATT INSULATION</p> <p>VAPOR BARRIER ON WARM SIDE</p> <p>(1) LAYERS TYPE "X" 5/8" GWB</p> <p>(1) LAYERS TYPE "X" DENS GLASS</p> | 1 HR            |

BRISTOL APARTMENTS  
9615 Bristol Ave SW, Lakewood, WA

| No. | Description        | Date   |
|-----|--------------------|--------|
| 1   | CITY PLAN COMMENTS | 4/7/20 |

WALL ASSEMBLIES

SCALE 1" = 1'-0"

5-6-19

A0.3



4/24/2020 9:50:26 AM G:\My Drive\2019 Projects\19-018 Bristol Apts Oleg\Drawings\Oleg Apartments - Arch jlb.rvt

PROJ ID 643  
PERMIT 900

RECEIVED  
10/10/2022  
City of Lakewood



LJB DESIGNS, LLC  
111 Market Street N.E., Suite 325  
Olympia, Washington 98501  
(360) 867-1945  
E-mail: LJBDesigns@Comcast.net

REVISIONS

| # | ISSUED      | DATE    |
|---|-------------|---------|
| 1 | CITY PERMIT | 4/27/20 |

12015 REGISTERED ARCHITECT  
JOSHUA EARL SMOGRASS  
STATE OF WASHINGTON

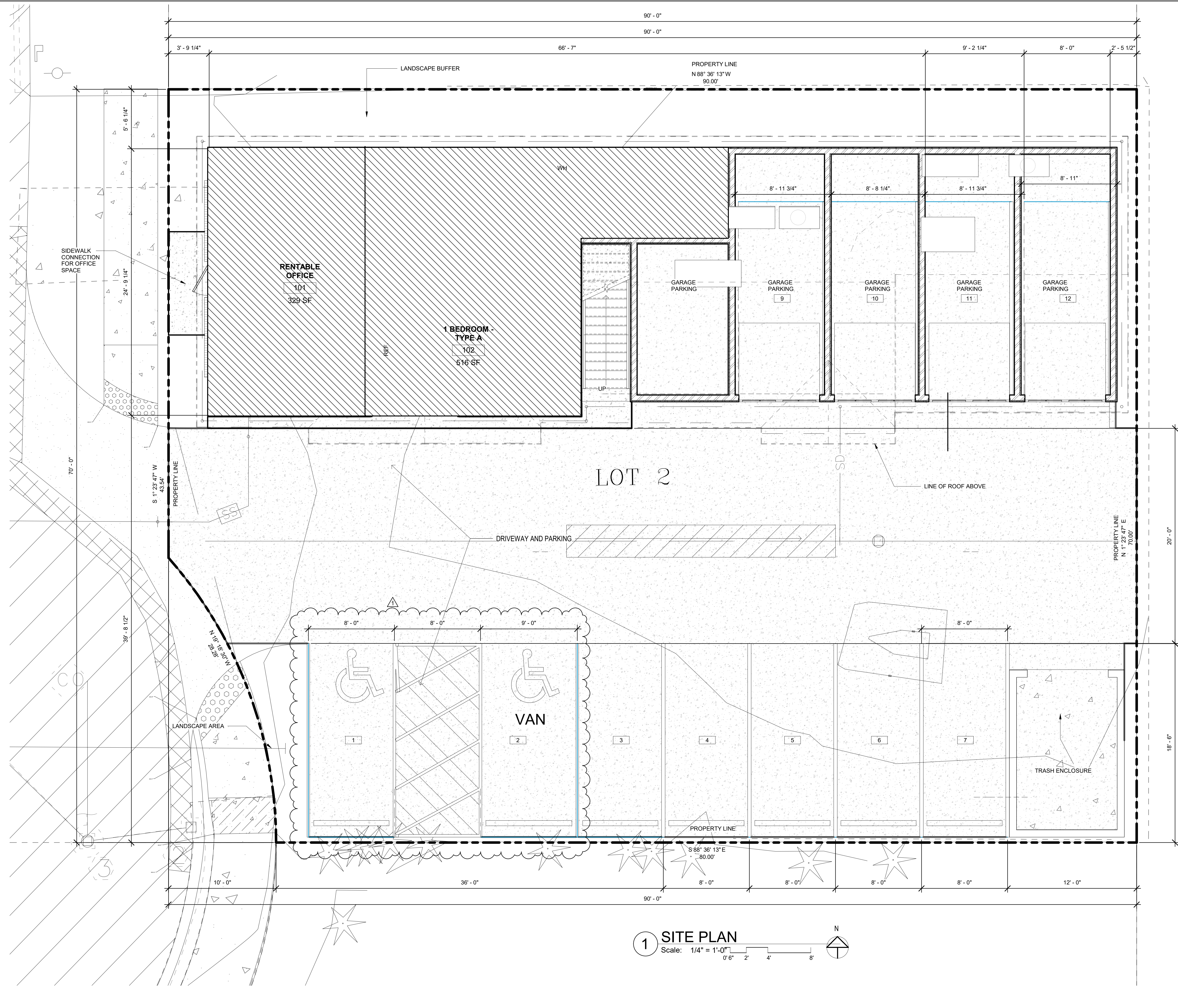

**SITE ADDRESS:** 9615 BRISTOL AVE SW, LAKEWOOD WA 98499

**ZONING:** CBD CENTRAL BUSINESS DISTRICT  
MULTIFAMILY DWELLING (LEVEL 2/3)

**PROPERTY INFORMATION**

|       |             |
|-------|-------------|
| ACRES | SQUARE FEET |
| 0.14  | 6119 SF     |

**DENSITY CALCULATIONS**

**REQUIRED** 54 DWELLING UNITS PER ACRE  
.14 ACRES X 54 DUA = 7.56 DU'S MAX

**PROPOSED** 7 DWELLING UNITS PROPOSED

**PROPOSED PARKING COUNT**

|    |                     |
|----|---------------------|
| 1  | Parking Space - ADA |
| 1  | Parking Space - ADA |
| 9  | Parking Space       |
| 11 |                     |

**SQUARE FOOTAGE CALCULATIONS**

|                         |          |
|-------------------------|----------|
| FIRST FLOOR:            | 1,974 SF |
| SECOND FLOOR:           | 2,033 SF |
| THIRD FLOOR:            | 2,033 SF |
| TOTAL GROSS FLOOR AREA: | 6,040 SF |

1 SITE PLAN  
Scale: 1/4" = 1'-0"

BRISTOL APARTMENTS  
9615 Bristol Ave SW, Lakewood, WA

SITE PLAN

A1.0





1910 EAST 4TH AVENUE PMB #170  
OLYMPIA, WA 98506  
PHONE: 360-528-0513  
JOSH@REVIVALARCHITECTS.COM

LJB DESIGNS, LLC  
111 Market Street N.E., Suite 325  
Olympia, Washington 98501  
(360) 867-1945

E-mail: LJBDesigns@Comcast.net

REVISIONS

| # | ISSUED   | DATE     |
|---|----------|----------|
| 1 | 12/15/20 | 12/15/20 |

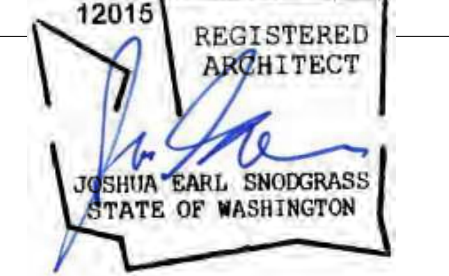

WALL ASSEMBLIES

NOTE: ALL NOTED NAILING REQUIREMENTS ARE MINIMUM AND ARE FOR MINIMUM FIRE RATINGS. SEE STRUCTURAL FOR ADDITIONAL REQUIREMENTS.

|    | DESCRIPTION  | RATING SOURCE                                  | SOUND RATING |
|----|--|--|--------------|
| W1 | <p>NOTE: PROVIDE ADDITIONAL GWB LAYER WHERE REQUIRED TO ALIGN WITH INTERIOR WALLS</p> <p>EXTERIOR SIDE: SIDING OVER WEATHER RESISTIVE BARRIER, 7/16" OSB SHEATHING UNO PER STRUCTURAL, 2x6 WOOD STUD FRAMING PER STRUCTURAL WOOD STUDS - SPACED 16 IN. OC WITH TWO 2 BY 6 IN. TOP AND ONE 2 BY 6 IN. BOTTOM PLATES. STUDS Laterally-Braced BY WOOD STRUCTURAL PANEL SHEATHING.</p> <p>INTERIOR SIDE: R-21 BATT INSULATION, 5/8" GWB TYPE "X" APPLY W/BD COATED NAILS, 1-7/8" LONG, 0.0915" SHANK, 1/4" HEAD, 7" OC LOAD BEARING.</p> | UL U366  |              |
| W2 | <p>DWELLING UNIT: 7/16 OSB WHERE REQ'D BY PER STRUCTURAL, MIN. 3 1/2" MINERAL FIBER INSULATION, 2x6 WOOD FRAMING @ 16" OC UNO PER STRUCTURAL, 1/2" RESILIENT CHANNEL @ 24" OC.</p> <p>DWELLING UNIT: (1) LAYER 5/8" TYPE "X" GWB (PROVIDE WATER RESISTANT GWB AT ALL WET WALLS).</p> <p>PENETRATIONS SHALL COMPLY WITH IBC SECTION 713.</p>  | GA FILE WP.3243 1 HR                           | 50-54 STC    |
| W3 | <p>NOTE: PROVIDE ADDITIONAL GWB LAYER WHERE REQUIRED TO ALIGN WITH INTERIOR WALLS</p> <p>EXTERIOR SIDE: SIDING OVER WEATHER RESISTIVE BARRIER, 5/8" TYPE "X" BENS GLASS SHEATHING, 2x6 WOOD STUD FRAMING PER STRUCTURAL, R-21 BATT INSULATION, 5/8" GWB TYPE "X" APPLY W/BD COATED NAILS, 1-7/8" LONG, 0.0915" SHANK, 1/4" HEAD, 7" OC LOAD BEARING.</p>   | GA 8105 1 HOUR                                 |              |
| W4 | <p>INTERIOR SIDE: PLYWOOD SHEATHING WHERE REQUIRED PER STRUCTURAL, 5/8" TYPE "X" GWB EACH SIDE (PROVIDE WATER RESISTANT GWB AT ALL WET WALLS).</p> <p>NOTE: WRAP ALL PLUMBING W/ SOUND INSULATION TYP AND FILL ENTIRE CAVITY WITH INSULATION.</p>  | GA 3510 2 X 4 WALLS, TYP. 2 X 6 BEHIND LAUNDRY | 35-39 STC    |

SEE SHEET A0.3 FOR FULL WALL ASSEMBLY DETAIL

MECHANICAL VENTILATION RATE

THE WHOLE-HOUSE MECHANICAL VENTILATION SYSTEM SHALL PROVIDE OUTDOOR AIR TO EACH HABITABLE SPACE AT A CONTINUOUS RATE OF NOT LESS THAN THAT DETERMINED IN ACCORDANCE WITH TABLE M1507.3.3(1)  
EXEMPTION: THE WHOLE-HOUSE MECHANICAL VENTILATION SYSTEM IS PERMITTED TO OPERATE INTERMITTENTLY WHERE THE SYSTEM HAS CONTROLS THAT ENABLE OPERATION FOR NOT LESS THAN 25 PERCENT OF EACH 4-HOUR SEGMENT AND THE VENTILATION RATE PRESCRIBED IN TABLE M1507.3.3(1) IS MULTIPLIED BY THE FACTOR DETERMINED IN ACCORDANCE WITH TABLE M1507.3.3(1)

| DWELLING UNIT FLOOR AREA (SQUARE FEET) | NUMBER OF BEDROOMS |     |     |     |     |
|--|--------------------|-----|-----|-----|-----|
|  | 0-1                | 2-3 | 4-5 | 6-7 | <7  |
| <1,500                                 | 30                 | 45  | 60  | 75  | 90  |
| 1,501-3,000                            | 45                 | 60  | 75  | 90  | 105 |
| 3,001-4,500                            | 60                 | 75  | 90  | 105 | 120 |
| 4,501-6,000                            | 75                 | 90  | 105 | 120 | 135 |
| 6,001-7,500                            | 90                 | 105 | 120 | 135 | 150 |
| >7,500                                 | 105                | 120 | 135 | 150 | 165 |

DUCT LEAKAGE PROTECTION:

DUCTS SHALL BE LEAK TESTED IN ACCORDANCE WITH WSU RS-33, USING THE MAXIMUM DUCT LEAKAGE RATES SPECIFIED

FLOOR PLAN NOTES:

- ALL EXTERIOR WALLS SHALL BE W1 or W3 U.N.O.
- ALL PARTY WALLS SHALL BE W2 U.N.O.
- SEE SHEET A0.1 FOR ACCESSIBLE DETAIL REQUIREMENTS.
- DIMENSIONS ARE TO STUD OR GRID LINE U.N.O.
- WINDOWS ARE DIMENSIONED TO CENTERLINE U.N.O.
- DOOR JAMBS ARE 4" FROM CORNER U.N.O.
- SEE SHEETS A7.0 FOR DOOR DETAILS AND SCHEDULE
- SEE SHEETS A7.0 FOR WINDOW DETAILS AND SCHEDULE
- TOILETS IN ADA UNITS ARE TO BE LOCATED MIN 18" CLEAR FROM THE CENTERLINE TO ANY OBSTRUCTION.
- CLOSETS SHALL HAVE THE SAME FINISHES AS THE CONNECTING ROOM, U.N.O.
- WASHER PANS TO BE USED IN ALL UNITS EXCEPT ADA UNITS. ADA UNITS TO HAVE FLOOR DRAINS.
- DIMENSION LUMBER FOR FLOOR FRAMING, TYP.

SQUARE FOOTAGE

- UNIT A: 515 SQ.FT.
- RENTABLE OFFICE: 330 SQ.FT.
- FIRE RISER: 119 SQ.FT.
- GARAGES: 185 SQ.FT.

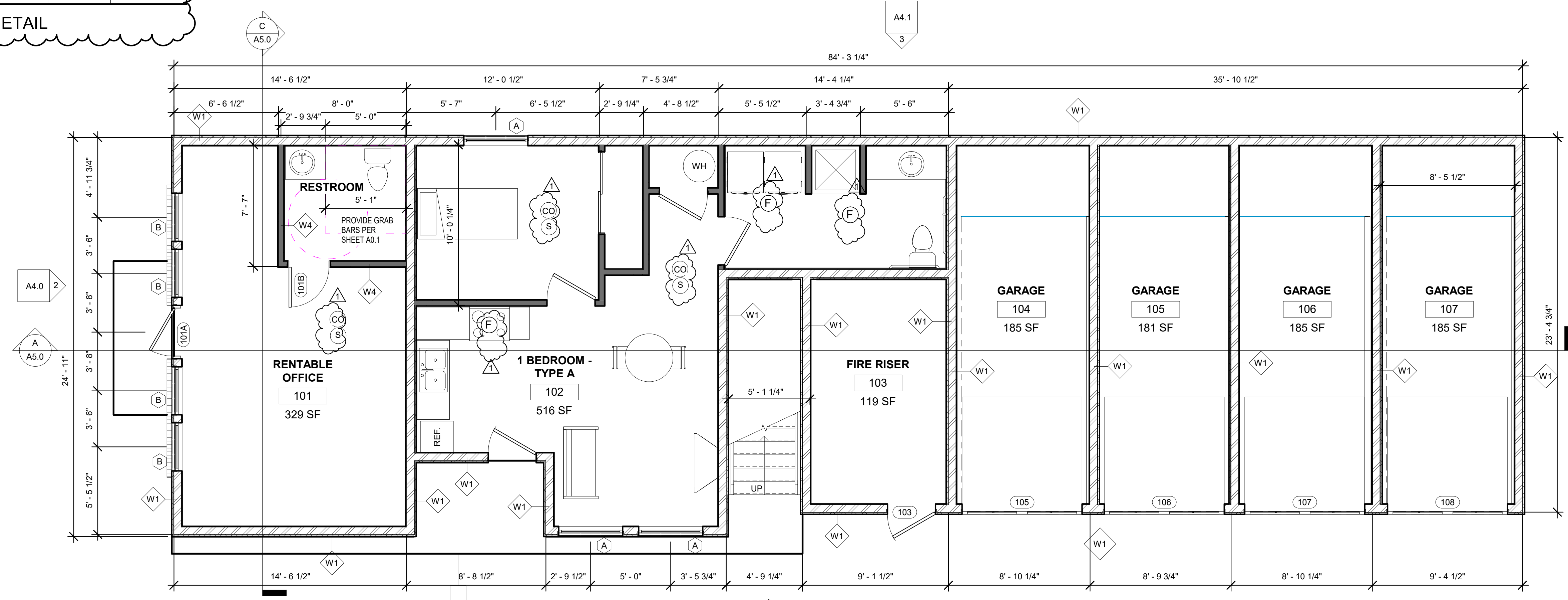

1 1ST FLOOR  
Scale: 1/4" = 1'-0"

BRISTOL APARTMENTS  
9615 Bristol Ave SW, Lakewood, WA

1ST FLOOR PLAN

A2.0

4/24/2020 9:50:27 AM G:\My Drive\2019 Projects\19-018 Bristol Apts Oleg\Drawings\Oleg Apartments - Arch jlb.rvt





1910 EAST 4TH AVENUE PMB #170  
OLYMPIA, WA 98506  
PHONE: 360-528-0513  
JOSH@REVIVALARCHITECTS.COM

LJB DESIGNS, LLC  
111 Market Street N.E., Suite 325  
Olympia, Washington 98501  
(360) 867-1945

E-mail: LJBDesigns@Comcast.net

REVISIONS

| # | ISSUED | DATE    |
|---|--------|---------|
| 1 | 12015  | 1/17/20 |
| 2 | 12015  | 1/20    |

REGISTERED ARCHITECT  
JOSHUA EARL SMOGGRASS  
STATE OF WASHINGTON

WALL ASSEMBLIES

NOTE: ALL NOTED NAILING REQUIREMENTS ARE MINIMUM AND ARE FOR MINIMUM FIRE RATINGS SEE STRUCTURAL FOR ADDITIONAL REQUIREMENTS.

|                             | DESCRIPTION  | RATING SOURCE                                  | SOUND RATING |
|-----------------------------|--|--|--------------|
| W1<br>TYPICAL EXTERIOR WALL | <p>NOTE: PROVIDE ADDITIONAL GWB LAYER WHERE REQUIRED TO ALIGN WITH INTERIOR WALLS</p> <p>EXTERIOR SIDE: SIDING OVER WEATHER RESISTIVE BARRIER, 7/16" OSB SHEATHING UNO PER STRUCTURAL, 2x6 WOOD STUD FRAMING PER STRUCTURALWOOD STUDS - SPACED 16 IN. OC WITH TWO 2 BY 8 IN. TOP AND ONE 2 BY 6 IN. BOTTOM PLATES. STUDS LATERALLY-BRACED BY WOOD STRUCTURAL PANEL SHEATHING.</p> <p>INTERIOR SIDE: R-21 BATT INSULATION, 5/8" GWB TYPE "X" APPLY W/6D COATED NAILS, 1-7/8" LONG, 0.0915" SHANK, 1/4" HEAD, 7" OC LOAD BEARING</p> | UL U366  |              |
| W2<br>TYP PARTY WALL        | <p>DWELLING UNIT: (1) LAYER 5/8" TYPE "X" GWB, 7/16 OSB WHERE REQ'D BY PER STRUCTURAL, MIN. 3 1/2" MINERAL FIBER INSULATION, 2x6 WOOD FRAMING @ 16" OC UNO PER STRUCTURAL, 1/2" RESILIENT CHANNEL @ 24" OC</p> <p>DWELLING UNIT: (1) LAYER 5/8" TYPE "X" GWB (PROVIDE WATER RESISTANT GWB AT ALL WET WALLS)</p> <p>PENETRATIONS SHALL COMPLY WITH IBC SECTION 713.</p>   | GA FILE WP 3243 1 HR                           | 50-54 STC    |
| W3<br>1 HR EXTERIOR WALL    | <p>NOTE: PROVIDE ADDITIONAL GWB LAYER WHERE REQUIRED TO ALIGN WITH INTERIOR WALLS</p> <p>EXTERIOR SIDE: SIDING OVER WEATHER RESISTIVE BARRIER, 5/8" TYPE "X" CLEAR GLASS SHEATHING, 2x6 WOOD STUD FRAMING PER STRUCTURAL, R-21 BATT INSULATION, 5/8" GWB TYPE "X" APPLY W/6D COATED NAILS, 1-7/8" LONG, 0.0915" SHANK, 1/4" HEAD, 7" OC LOAD BEARING</p>   | GA 8105 1 HOUR                                 |              |
| W4<br>TYP INTERIOR WALL     | <p>INTERIOR SIDE: PLYWOOD SHEATHING WHERE REQUIRED PER STRUCTURAL, 5/8" TYPE "X" GWB EACH SIDE (PROVIDE WATER RESISTANT GWB AT ALL WET WALLS)</p> <p>NOTE: WRAP ALL PLUMBING W/SOUND INSULATION TYP AND FILL ENTIRE CAVITY WITH INSULATION.</p>  | GA 3510 2 X 4 WALLS, TYP. 2 X 6 BEHIND LAUNDRY | 35-39 STC    |

SEE SHEET A0.3 FOR FULL WALL ASSEMBLY DETAIL

MECHANICAL VENTILATION RATE

THE WHOLE-HOUSE MECHANICAL VENTILATION SYSTEM SHALL PROVIDE OUTDOOR AIR TO EACH HABITABLE SPACE AT A CONTINUOUS RATE OF NOTE LESS THAN THAT DETERMINED IN ACCORDANCE WITH TABLE M1507.3.3(1)  
EXEMPTION: THE WHOLE-HOUSE MECHANICAL VENTILATION SYSTEM IS PERMITTED TO OPERATE INTERMITTENTLY WHERE THE SYSTEM HAS CONTROLS THAT ENABLE OPERATION FOR NOT LESS THAN 25 PERCENT OF EACH 4-HOUR SEGMENT AND THE VENTILATION RATE PRESCRIBED IN TABLE M1507.3.3(1) IS MULTIPLIED BY THE FACTOR DETERMINED IN ACCORDANCE WITH TABLE M1507.3.3(1)

| DWELLING UNIT FLOOR AREA (SQUARE FEET) | NUMBER OF BEDROOMS |     |     |     |     |
|--|--------------------|-----|-----|-----|-----|
|  | 0-1                | 2-3 | 4-5 | 6-7 | <7  |
| <1,500                                 | 30                 | 45  | 60  | 75  | 90  |
| 1,501-3,000                            | 45                 | 60  | 75  | 90  | 105 |
| 3,001-4,500                            | 60                 | 75  | 90  | 105 | 120 |
| 4,501-6,000                            | 75                 | 90  | 105 | 120 | 135 |
| 6,001-7,500                            | 90                 | 105 | 120 | 135 | 150 |
| >7,500                                 | 105                | 120 | 135 | 150 | 165 |

DUCT LEAKAGE PROTECTION:

DUCTS SHALL BE LEAK TESTED IN ACCORDANCE WITH WSU RS-33, USING THE MAXIMUM DUCT LEAKAGE RATES SPECIFIED

FLOOR PLAN NOTES:

- ALL EXTERIOR WALLS SHALL BE W1 or W3 U.N.O.
- ALL PARTY WALLS SHALL BE W2 U.N.O.
- SEE SHEET A0.1 FOR ACCESSIBLE DETAIL REQUIREMENTS.
- DIMENSIONS ARE TO STUD OR GRID LINE U.N.O.
- WINDOWS ARE DIMENSIONED TO CENTERLINE U.N.O.
- DOOR JAMBS ARE 4" FROM CORNER U.N.O.
- SEE SHEETS A7.0 FOR DOOR DETAILS AND SCHEDULE
- SEE SHEETS A7.0 FOR WINDOW DETAILS AND SCHEDULE
- TOILETS IN ADA UNITS ARE TO BE LOCATED MIN 18" CLEAR FROM THE CENTERLINE TO ANY OBSTRUCTION.
- CLOSETS SHALL HAVE THE SAME FINISHES AS THE CONNECTING ROOM, U.N.O.
- WASHER PANS TO BE USED IN ALL UNITS EXCEPT ADA UNITS. ADA UNITS TO HAVE FLOOR DRAINS.
- DIMENSION LUMBER FOR FLOOR FRAMING, TYP.

SQUARE FOOTAGE

UNIT B: 402 SQ.FT. DECK: 51 SQ.FT.  
UNIT C: 445 SQ.FT. DECK: 45 SQ.FT.  
UNIT D: 621 SQ.FT. DECK: 50 SQ.FT.  
EXTERIOR CORRIDOR: 336 SQ.FT.

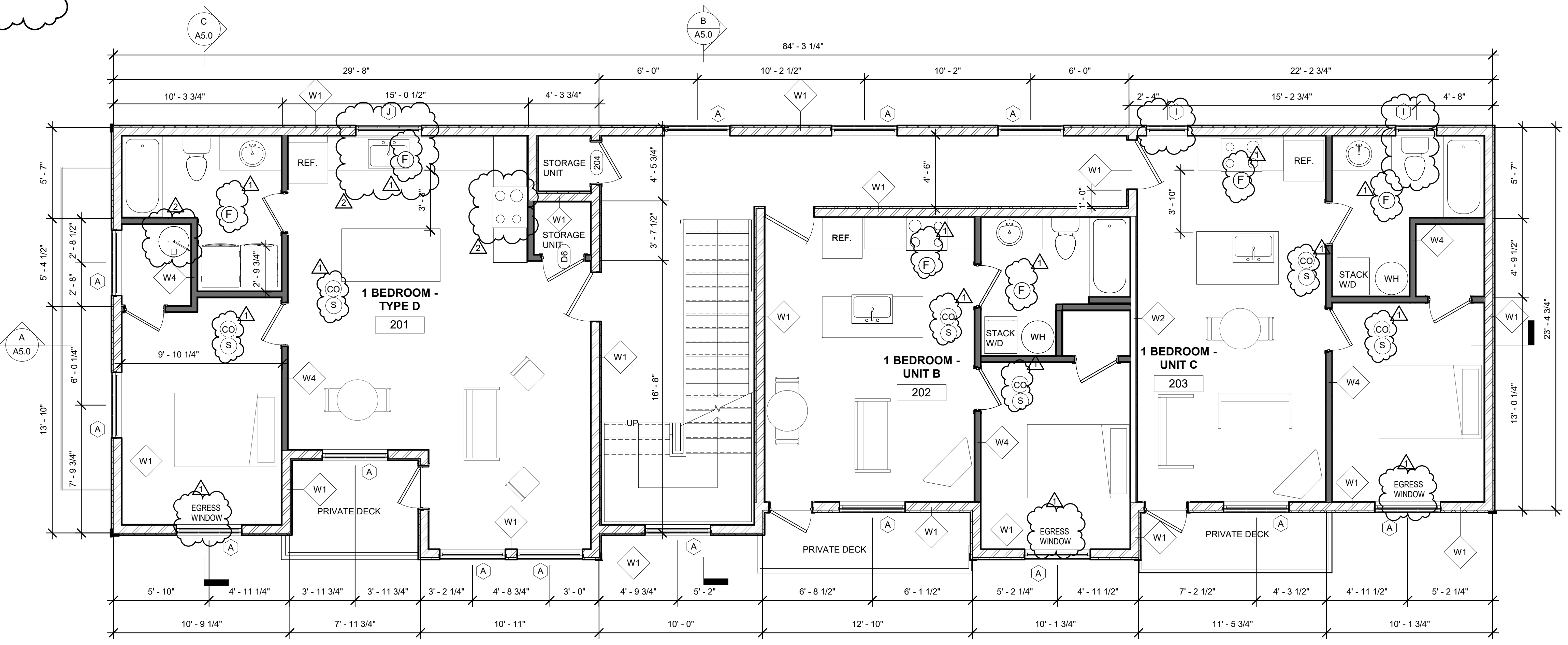

1 2ND FLOOR  
Scale: 1/4" = 1'-0"

BRISTOL APARTMENTS  
9615 Bristol Ave SW, Lakewood, WA

2ND FLOOR PLAN

A2.1

4/24/2020 9:50:28 AM G:\My Drive\2019 Projects\19-018 Bristol Apts Oleg\Drawings\Oleg Apartments - Arch jlb.rvt





1910 EAST 4TH AVENUE PMB #170  
OLYMPIA, WA 98506  
PHONE: 360-528-0513  
JOSH@REVIVALARCHITECTS.COM

LJB DESIGNS, LLC  
111 Market Street N.E., Suite 325  
Olympia, Washington 98501  
(360) 867-1945

E-mail: LJBDesigns@Comcast.net

REVISIONS

| # | ISSUED               | DATE |
|---|----------------------|------|
| 1 | 12015                | 1/20 |
| 2 | REGISTERED ARCHITECT | 1/20 |

WALL ASSEMBLIES

NOTE: ALL NOTED NAILING REQUIREMENTS ARE MINIMUM AND ARE FOR MINIMUM FIRE RATINGS SEE STRUCTURAL FOR ADDITIONAL REQUIREMENTS.

|    | DESCRIPTION  | RATING SOURCE                                  | SOUND RATING |
|----|--|--|--------------|
| W1 | <p>NOTE: PROVIDE ADDITIONAL GWB LAYER WHERE REQUIRED TO ALIGN WITH INTERIOR WALLS</p> <p>EXTERIOR SIDE: SIDING OVER WEATHER RESISTIVE BARRIER, 7/16" OSB SHEATHING UNO PER STRUCTURAL</p> <p>INTERIOR SIDE: 2x6 WOOD STUD FRAMING PER STRUCTURAL WOOD STUDS - SPACED 16 IN. OC WITH TWO 2 BY 6 IN. TOP AND ONE 2 BY 6 IN. BOTTOM PLATES. STUDS LATERALLY-BRACED BY WOOD STRUCTURAL PANEL SHEATHING.</p> <p>R-21 BATT INSULATION</p> <p>5/8" GWB TYPE "X" APPLY W/BD COATED NAILS, 1-7/8" LONG, 0.0915" SHANK, 1/4" HEAD, 7" OC LOAD BEARING</p> <p>(1) LAYER 5/8" TYPE "X" GWB</p> | UL U556  |              |
| W2 | <p>DWELLING UNIT</p> <p>7/16 OSB WHERE REQ'D BY PER STRUCTURAL</p> <p>MIN. 3 1/2" MINERAL FIBER INSULATION</p> <p>2x6 WOOD FRAMING @ 16" OC UNO PER STRUCTURAL</p> <p>1/2" RESILIENT CHANNEL @ 24" OC</p> <p>DWELLING UNIT</p> <p>(1) LAYER 5/8" TYPE "X" GWB (PROVIDE WATER RESISTANT GWB AT ALL WET WALLS)</p> <p>PENETRATIONS SHALL COMPLY WITH IBC SECTION 713.</p>  | GA FILE WP 3243 1 HR                           | 50-54 STC    |
| W3 | <p>NOTE: PROVIDE ADDITIONAL GWB LAYER WHERE REQUIRED TO ALIGN WITH INTERIOR WALLS</p> <p>EXTERIOR SIDE: SIDING OVER WEATHER RESISTIVE BARRIER, 5/8" TYPE "X" DENS GLASS SHEATHING</p> <p>2x6 WOOD STUD FRAMING PER STRUCTURAL</p> <p>R-21 BATT INSULATION</p> <p>5/8" GWB TYPE "X" APPLY W/BD COATED NAILS, 1-7/8" LONG, 0.0915" SHANK, 1/4" HEAD, 7" OC LOAD BEARING</p>  | GA 8105 1 HOUR                                 |              |
| W4 | <p>INTERIOR SIDE: PLYWOOD SHEATHING WHERE REQUIRED PER STRUCTURAL</p> <p>5/8" TYPE "X" GWB EACH SIDE (PROVIDE WATER RESISTANT GWB AT ALL WET WALLS)</p> <p>NOTE: WRAP ALL PLUMBING W/ SOUND INSULATION TYP AND FILL ENTIRE CAVITY WITH INSULATION.</p>   | GA 3510 2 X 4 WALLS, TYP. 2 X 6 BEHIND LAUNDRY | 35-39 STC    |

MECHANICAL VENTILATION RATE

THE WHOLE-HOUSE MECHANICAL VENTILATION SYSTEM SHALL PROVIDE OUTDOOR AIR TO EACH HABITABLE SPACE AT A CONTINUOUS RATE OF NOTE LESS THAN THAT DETERMINED IN ACCORDANCE WITH TABLE M1507.3.3(1)

EXEMPTION: THE WHOLE-HOUSE MECHANICAL VENTILATION SYSTEM IS PERMITTED TO OPERATE INTERMITTENTLY WHERE THE SYSTEM HAS CONTROLS THAT ENABLE OPERATION FOR NOT LESS THAN 25 PERCENT OF EACH 4-HOUR SEGMENT AND THE VENTILATION RATE PRESCRIBED IN TABLE M1507.3.3(1) IS MULTIPLIED BY THE FACTOR DETERMINED IN ACCORDANCE WITH TABLE M1507.3.3(1)

| DWELLING UNIT FLOOR AREA (SQUARE FEET) | NUMBER OF BEDROOMS |     |     |     |     |
|--|--------------------|-----|-----|-----|-----|
|  | 0-1                | 2-3 | 4-5 | 6-7 | <7  |
| <1,500                                 | 30                 | 45  | 60  | 75  | 90  |
| 1,501-3,000                            | 45                 | 60  | 75  | 90  | 105 |
| 3,001-4,500                            | 60                 | 75  | 90  | 105 | 120 |
| 4,501-6,000                            | 75                 | 90  | 105 | 120 | 135 |
| 6,001-7,500                            | 90                 | 105 | 120 | 135 | 150 |
| >7,500                                 | 105                | 120 | 135 | 150 | 165 |

DUCT LEAKAGE PROTECTION:

DUCTS SHALL BE LEAK TESTED IN ACCORDANCE WITH WSU RS-33, USING THE MAXIMUM DUCT LEAKAGE RATES SPECIFIED

FLOOR PLAN NOTES:

- ALL EXTERIOR WALLS SHALL BE W1 or W3 U.N.O.
- ALL PARTY WALLS SHALL BE W2 U.N.O.
- SEE SHEET A0.1 FOR ACCESSIBLE DETAIL REQUIREMENTS.
- DIMENSIONS ARE TO STUD OR GRID LINE U.N.O.
- WINDOWS ARE DIMENSIONED TO CENTERLINE U.N.O.
- DOOR JAMBS ARE 4" FROM CORNER U.N.O.
- SEE SHEETS A7.0 FOR DOOR DETAILS AND SCHEDULE
- SEE SHEETS A7.0 FOR WINDOW DETAILS AND SCHEDULE
- TOILETS IN ADA UNITS ARE TO BE LOCATED MIN 18" CLEAR FROM THE CENTERLINE TO ANY OBSTRUCTION.
- CLOSETS SHALL HAVE THE SAME FINISHES AS THE CONNECTING ROOM, U.N.O.
- WASHER PANS TO BE USED IN ALL UNITS EXCEPT ADA UNITS. ADA UNITS TO HAVE FLOOR DRAINS.
- DIMENSION LUMBER FOR FLOOR FRAMING, TYP.

SQUARE FOOTAGE

UNIT B: 402 SQ.FT. DECK: 51 SQ.FT.  
UNIT C: 445 SQ.FT. DECK: 45 SQ.FT.  
UNIT D: 621 SQ.FT. DECK: 50 SQ.FT.  
EXTERIOR CORRIDOR: 336 SQ.FT.

SEE SHEET A0.3 FOR FULL WALL ASSEMBLY DETAIL

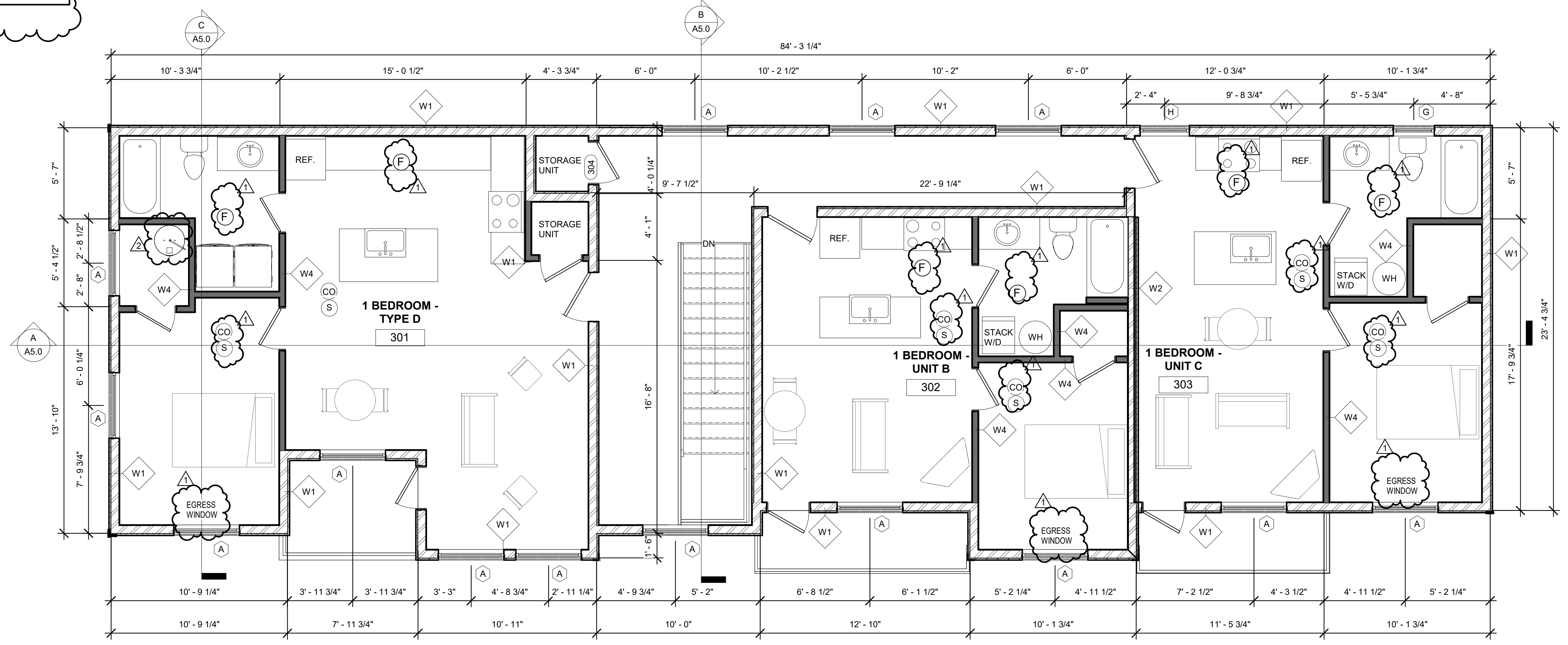

1 3RD FLOOR  
Scale: 1/4" = 1'-0"

BRISTOL APARTMENTS  
9615 Bristol Ave SW, Lakewood, WA

3RD FLOOR PLAN

A2.2

4/24/2020 9:50:29 AM G:\My Drive\2019 Projects\19-018 Bristol Apts Oleg\Drawings\Oleg Apartments - Arch jlb.rvt

PROJ ID 643  
 PERMIT 900  
 RECEIVED  
 10/10/2022  
 City of Lakewood



LJB DESIGNS, LLC  
 111 Market Street N.E., Suite 325  
 Olympia, Washington 98501  
 (360) 867-1945  
 E-mail: LJBDesigns@Comcast.net

| ROOF AREA VENTING |            |                  |            |            |           |                  |
|-------------------|------------|------------------|------------|------------|-----------|------------------|
| ROOF AREA         | AREA       | VENTING REQUIRED | GABLE VENT | RIDGE VENT | EAVE VENT | VENTING PROVIDED |
| ROOF AREA A       | 1,559 S.F. | 749 S.I.         | 112 S.I.   | 15 LF REQ. | 64 S.I.   | 916 S.I.         |
| ROOF AREA B       | 1,989 S.F. | 955 S.I.         | 56 S.I.    | 24 LF REQ. | 91 S.I.   | 1,049 S.I.       |

**ROOF NOTES:**

1. DS = DOWNSPOUT
2. PROVIDE VENT HOLES IN PLYWOOD SHEATHING BENEATH OVERFRAMED VENTED ROOFS
3. PROVIDE VAPOR BARRIER ON WARM SIDE OF ALL ATTICS
5. ROOF PITCH 6:12 U. N. O.
6. ROOF OVERHANG 1'-0" U. N. O.
7. FOR ROOF ASSEMBLIES SEE SHEET A5.0
8. DRAFTSTOP ACCESS DOORS SHALL BE PROVIDED WITH AUTOMATIC LATCHES PER IBC SECTION 717.4.1.1
9. REQUIRED NET FREE VENTILATION AREA = 1/300TH OF AREA TO BE VENTILATED
10. PROVIDE RAT RUN (CONSISTING OF 2 2X10s) THROUGH DRAFTSTOP ACCESS DOORS AND TO MECHANICAL EQUIPMENT LOCATIONS AS NEEDED

**VENT NOTES:**

- RIDGE VENT = 17 SI (SQUARE INCHES) PER LINEAL FOOT
- EAVE VENT = 2 1/2" DIAMETER HOLES (4.9 SI PER HOLE) 2 PER FRAMING BAY
- GABLE VENT = TRIANGULAR VENT 4:12 PITCH 56 SI PER VENT

REVISIONS

| # | ISSUED | DATE |
|---|--------|------|
|   |        |      |

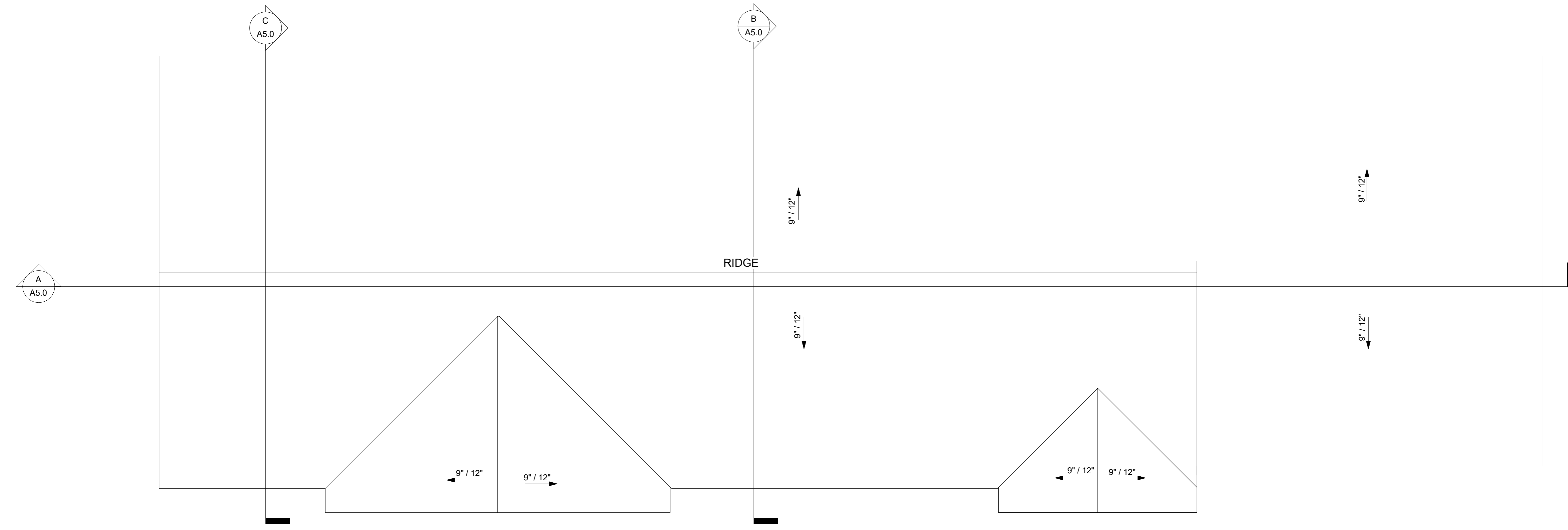
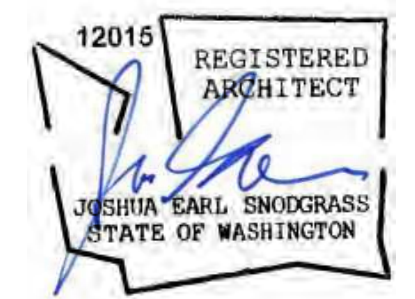

**A ROOF PLAN**  
 Scale: 1/4" = 1'-0"  
 0' 6" 2' 4' 8"

BRISTOL APARTMENTS  
 9615 Bristol Ave SW, Lakewood, WA

ROOF PLAN

A2.3



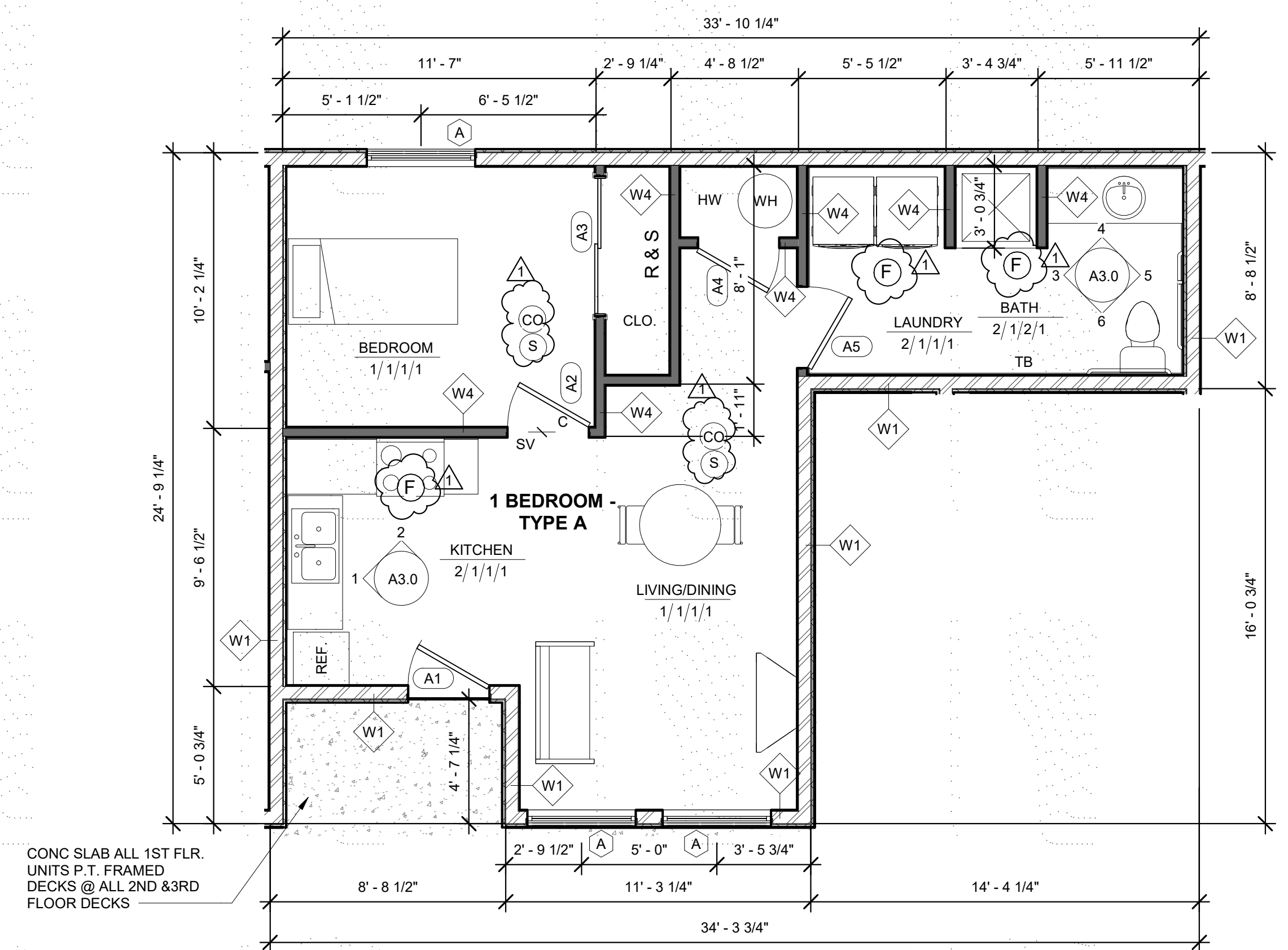

**A UNIT TYPE A ONE BEDROOM**  
1/4" = 1'-0"

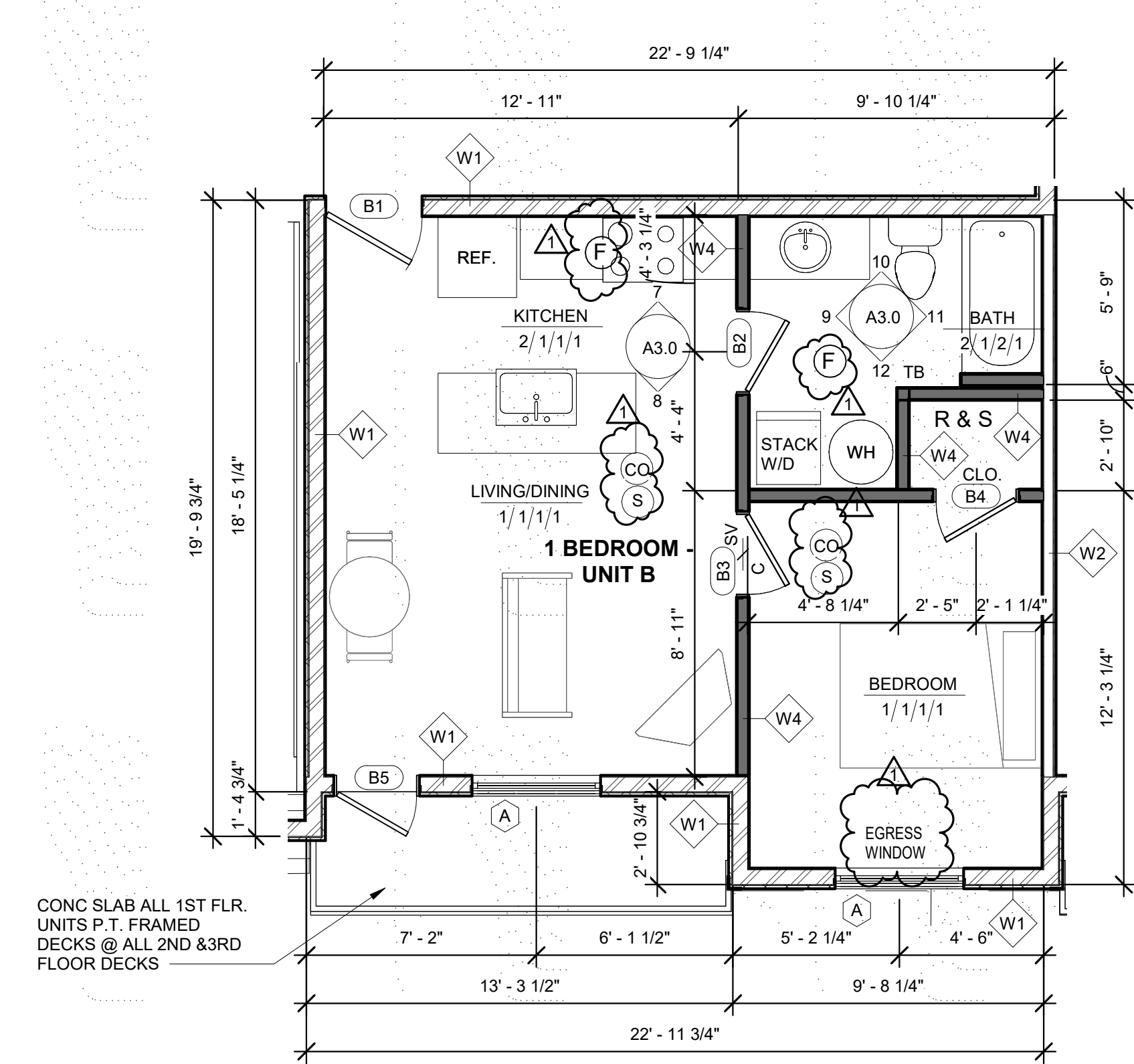

**B UNIT TYPE B ONE BEDROOM**  
1/4" = 1'-0"

**FINISH SCHEDULE**

**FLOOR:**  
1. CARPET (C)  
2. SHEET VINYL (SV)  
3. CONCRETE SEALED (CONC)

**BASE:**  
1. RUBBER BASE  
2. NO BASE

**WALLS:**  
1. PAINTED GWB  
2. PAINTED WATER RESISTANT GWB  
3. UNPAINTED GWB  
FIRE TAP GWB  
NO TEXTURE  
NO PAINT  
AND/OR CONCRETE

**KEY: ROOM NAME**  
X / X / X / X

**FLOOR**  
**BASE**  
**WALLS**  
**CEILING**

**CEILING:**  
1. PAINTED GWB  
2. UNPAINTED GWB  
3. NONE

- REVISIONS**
- | # | ISSUED    | DATE    |
|---|-----------|---------|
| 1 | CITY CALL | 4/20/20 |
- 12015 REGISTERED ARCHITECT  
JOSHUA EARL SMOGRASS  
STATE OF WASHINGTON
- CO CARBON MONOXIDE DETECTOR  
S SMOKE DETECTOR  
\*\* COMBO DETECTOR IS ALLOWED

- FLOOR PLAN NOTES:**
- ALL EXTERIOR WALLS SHALL BE W1 or W3 U.N.O.
  - ALL PARTY WALLS SHALL BE W2 U.N.O.
  - SEE SHEET A0.1 FOR ACCESSIBLE DETAIL REQUIREMENTS.
  - DIMENSIONS ARE TO STUD OR GRID LINE U.N.O.
  - WINDOWS ARE DIMENSIONED TO CENTERLINE U.N.O.
  - DOOR JAMBS ARE 4" FROM CORNER U.N.O.
  - SEE SHEETS A7.0 FOR DOOR DETAILS AND SCHEDULE
  - SEE SHEETS A7.0 FOR WINDOW DETAILS AND SCHEDULE
  - TOILETS IN ADA UNITS ARE TO BE LOCATED MIN 18" CLEAR FROM THE CENTERLINE TO ANY OBSTRUCTION.
  - CLOSETS SHALL HAVE THE SAME FINISHES AS THE CONNECTING ROOM, U.N.O.
  - WASHER PANS TO BE USED IN ALL UNITS EXCEPT ADA UNITS. ADA UNITS TO HAVE FLOOR DRAINS.
  - DIMENSION LUMBER FOR FLOOR FRAMING, TYP.

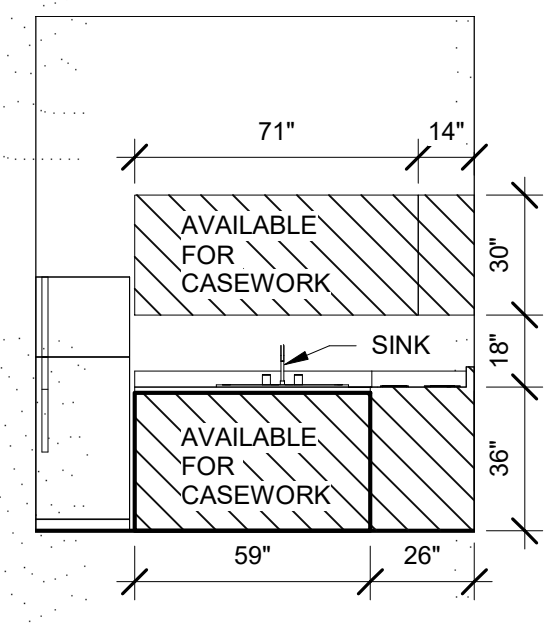

**1 KITCHEN**  
1/4" = 1'-0"

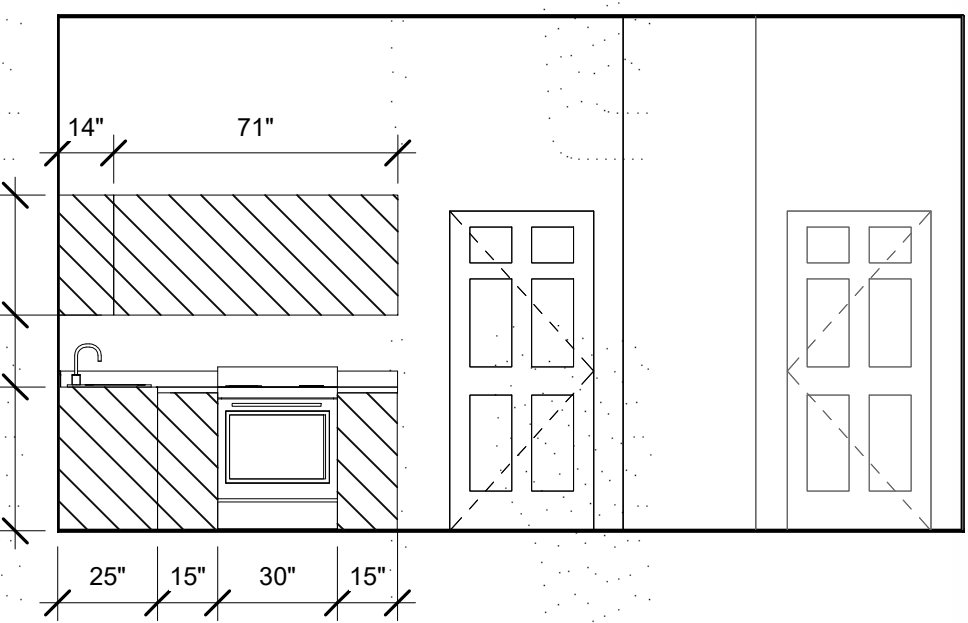

**2 KITCHEN**  
1/4" = 1'-0"

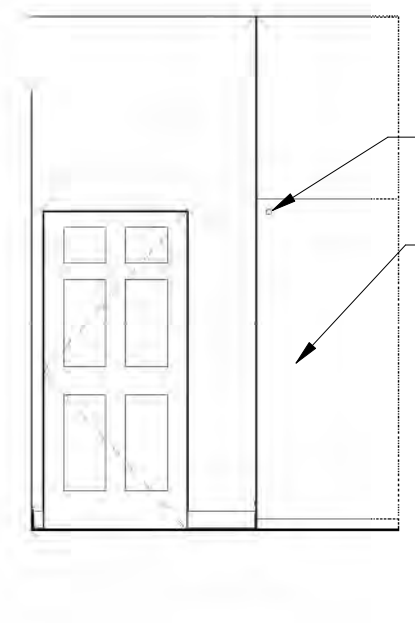

**3 BATH**  
1/4" = 1'-0"

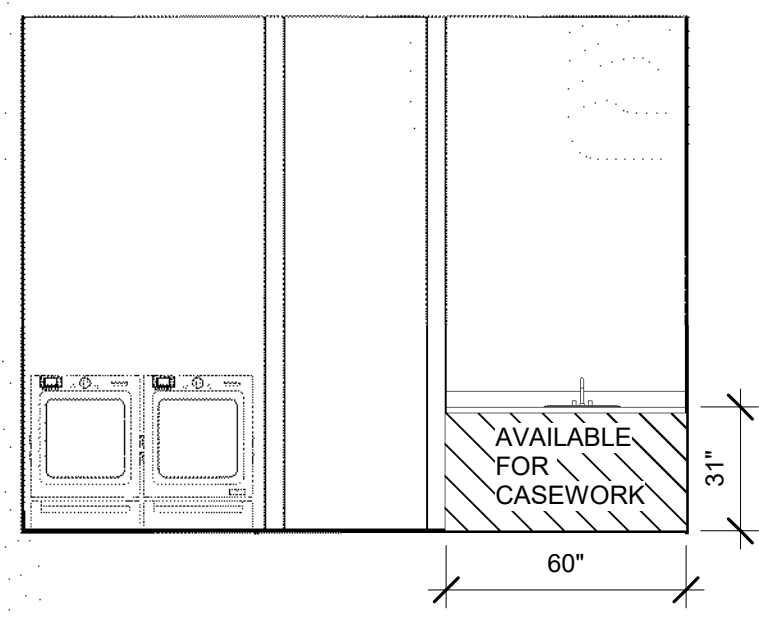

**4 BATH**  
1/4" = 1'-0"

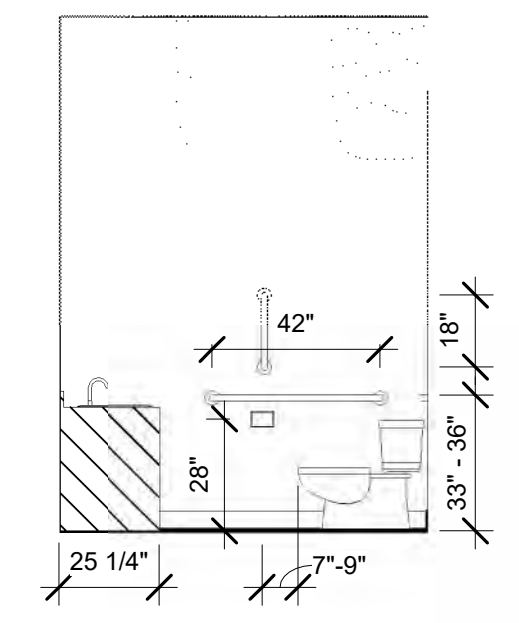

**5 BATH**  
1/4" = 1'-0"

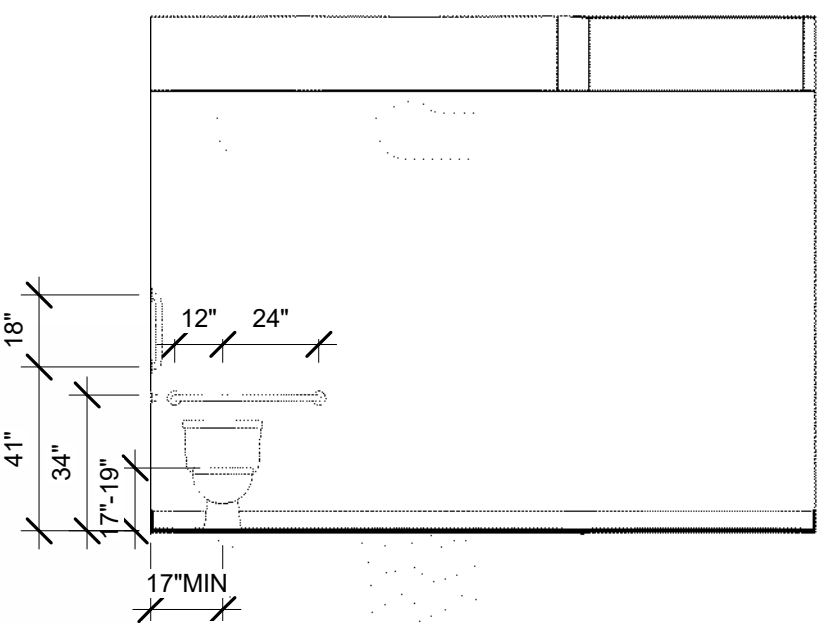

**6 BATH**  
1/4" = 1'-0"

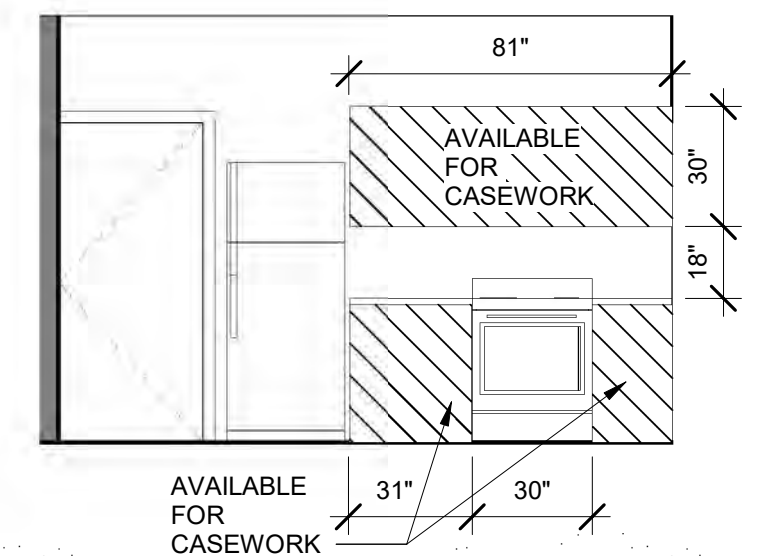

**7 KITCHEN**  
1/4" = 1'-0"

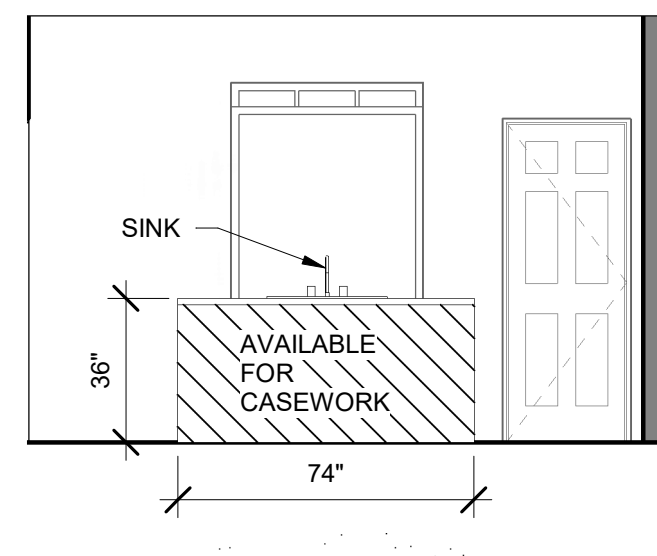

**8 KITCHEN**  
1/4" = 1'-0"

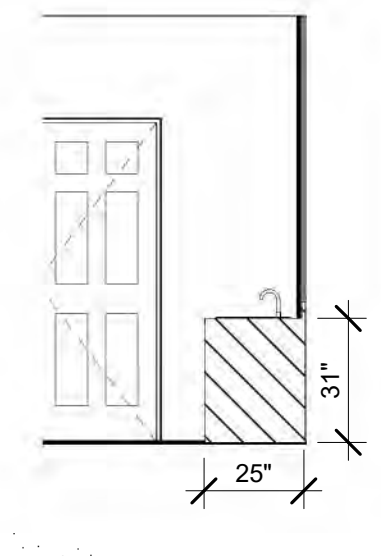

**9 BATH**  
1/4" = 1'-0"

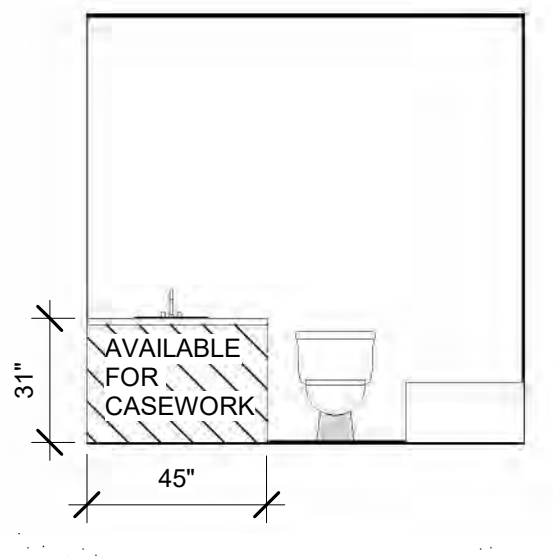

**10 BATH**  
1/4" = 1'-0"

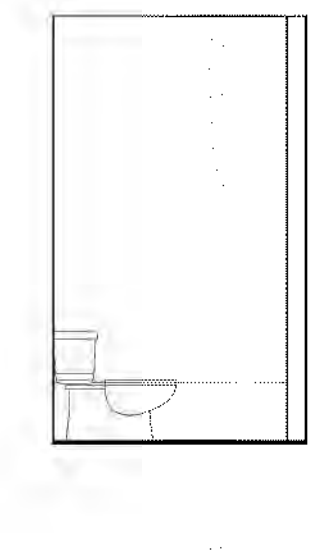

**11 BATH**  
1/4" = 1'-0"

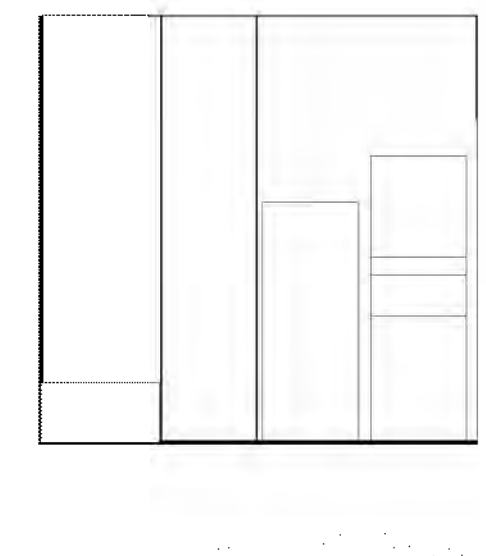

**12 BATH**  
1/4" = 1'-0"

**DOOR SCHEDULE UNIT A & B**

| NO. | TYPE | DOOR MAT'L | DOOR FINISH | Width | Height | Thickness | FRAME TYPE | FRAME FINISH | UL RTG | HARDWARE | REMARKS |
|-----|------|------------|-------------|-------|--------|-----------|------------|--------------|--------|----------|---------|
| A1  | A    | WD         | PAINT       | 3'-0" | 6'-8"  | 0'-1 3/4" | METAL      | PAINT        |        |          |         |
| A2  | B    | WD         | PAINT       | 3'-0" | 6'-8"  | 0'-1 3/8" |            | PAINT        |        |          |         |
| A3  | C    | WD         | PAINT       | 5'-0" | 6'-8"  | 0'-1 3/8" |            | PAINT        |        |          |         |
| A4  | B    | WD         | PAINT       | 3'-0" | 6'-8"  | 0'-1 3/8" |            | PAINT        |        |          |         |
| A5  | B    | WD         | PAINT       | 3'-0" | 6'-8"  | 0'-1 3/8" |            | PAINT        |        |          |         |
| B1  | A    | WD         | PAINT       | 3'-0" | 6'-8"  | 0'-1 3/4" | METAL      | PAINT        |        |          |         |
| B2  | B    | WD         | PAINT       | 2'-6" | 6'-8"  | 0'-1 3/4" |            | PAINT        |        |          |         |
| B3  | B    | WD         | PAINT       | 2'-6" | 6'-8"  | 0'-1 3/4" |            | PAINT        |        |          |         |
| B4  | B    | WD         | PAINT       | 2'-6" | 6'-8"  | 0'-1 3/4" |            | PAINT        |        |          |         |
| B5  | B    | WD         | PAINT       | 2'-6" | 6'-8"  | 0'-1 3/4" |            | PAINT        |        |          |         |

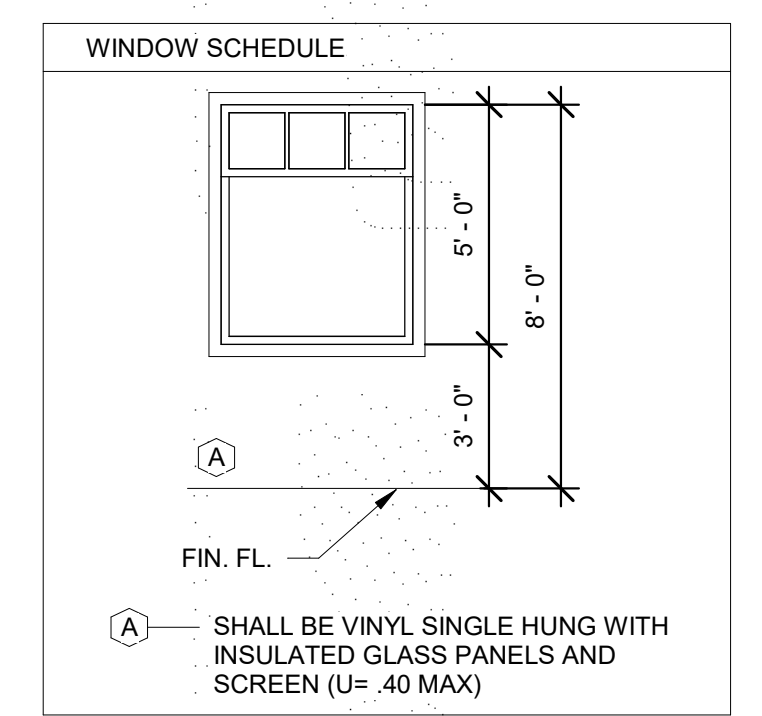
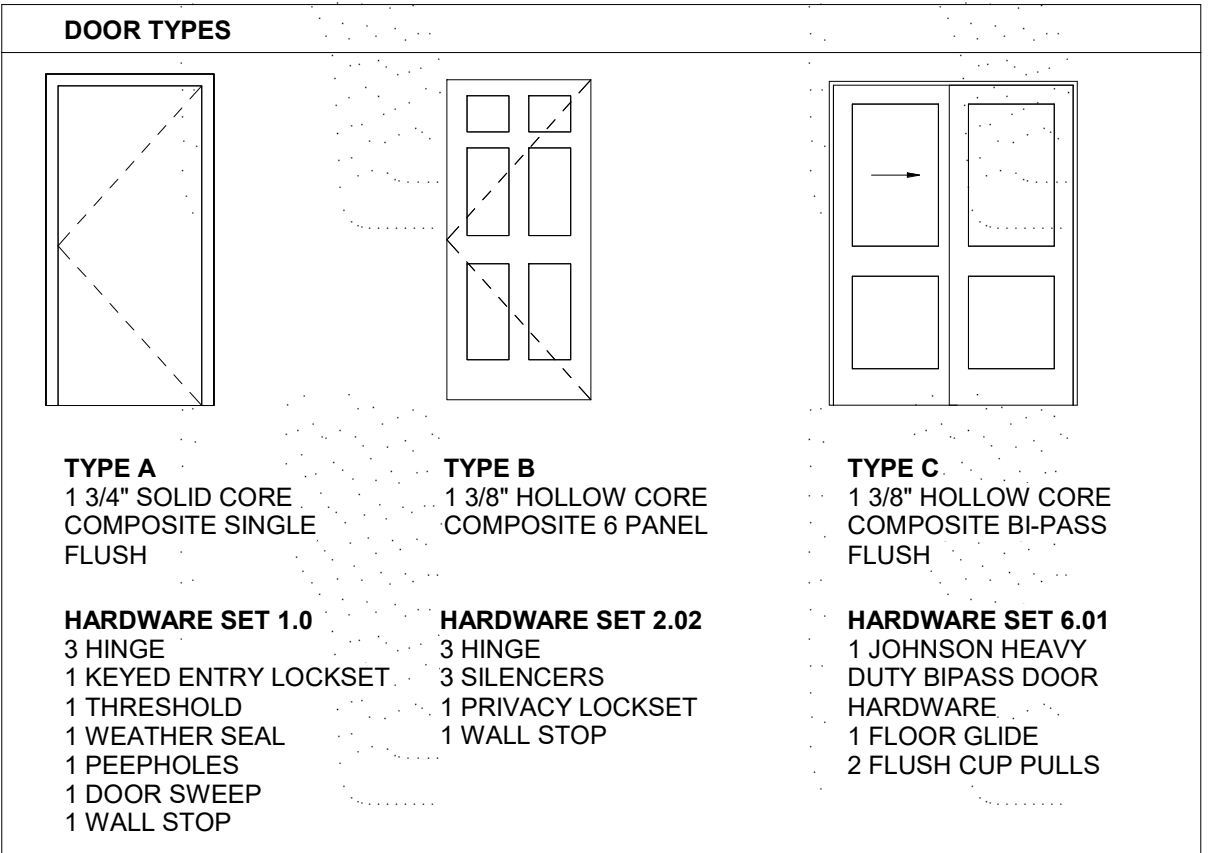

**LJB DESIGNS, LLC**  
111 Market Street N.E., Suite 325  
Olympia, Washington 98501  
(360) 867-1945  
E-mail: LJBDesigns@Comcast.net

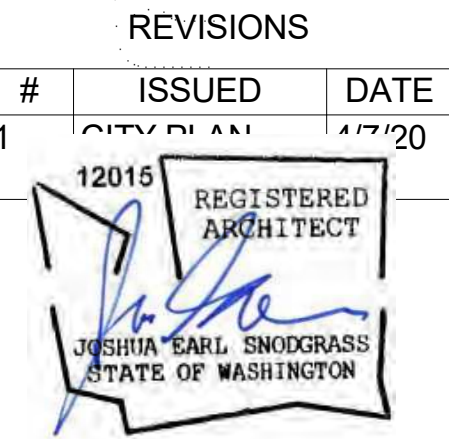

**BRISTOL APARTMENTS**  
9615 Bristol Ave SW, Lakewood, WA

**ENLARGED UNIT A & UNIT B PLANS**



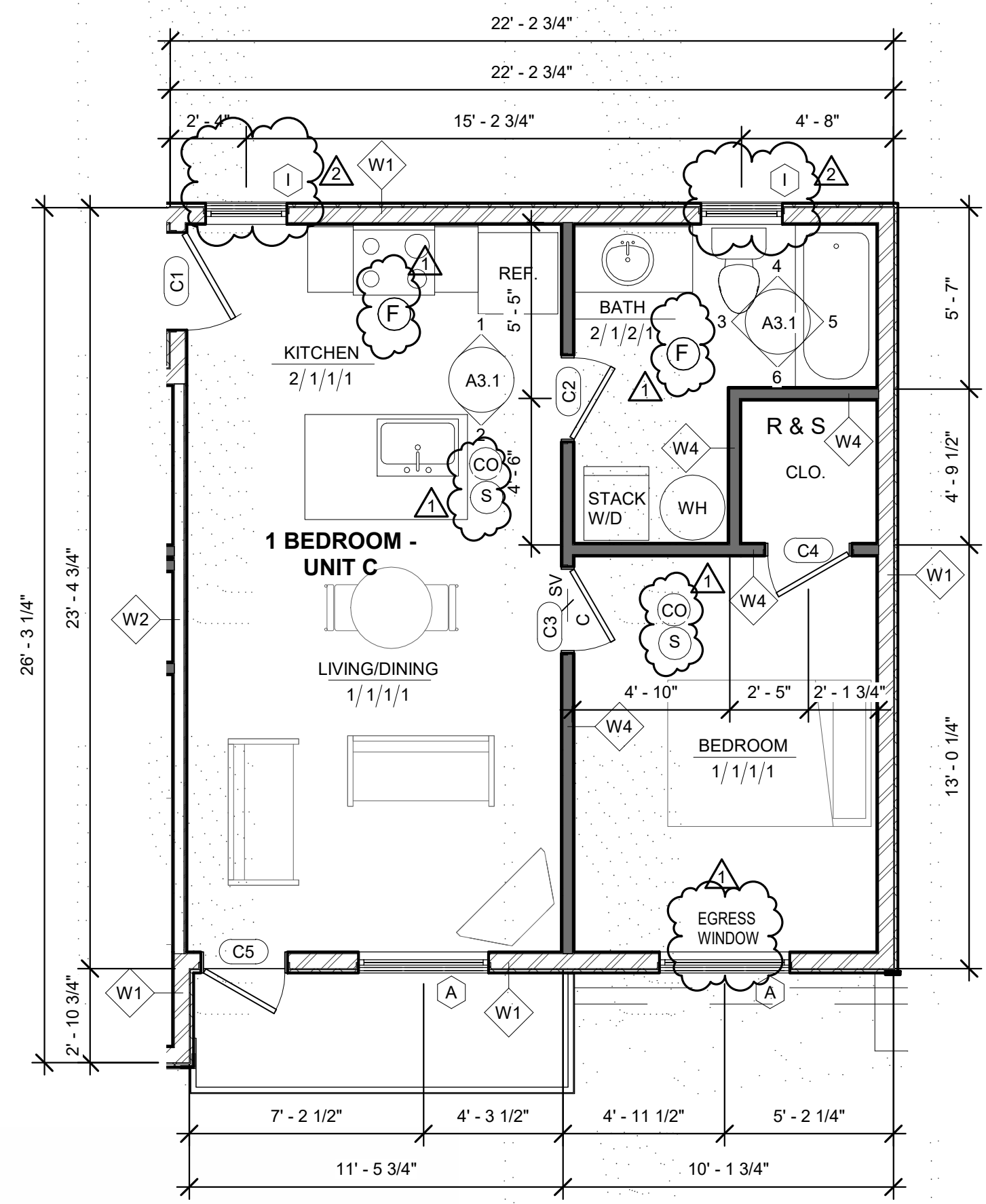

**A** UNIT TYPE C ONE BEDROOM  
1/4" = 1'-0"

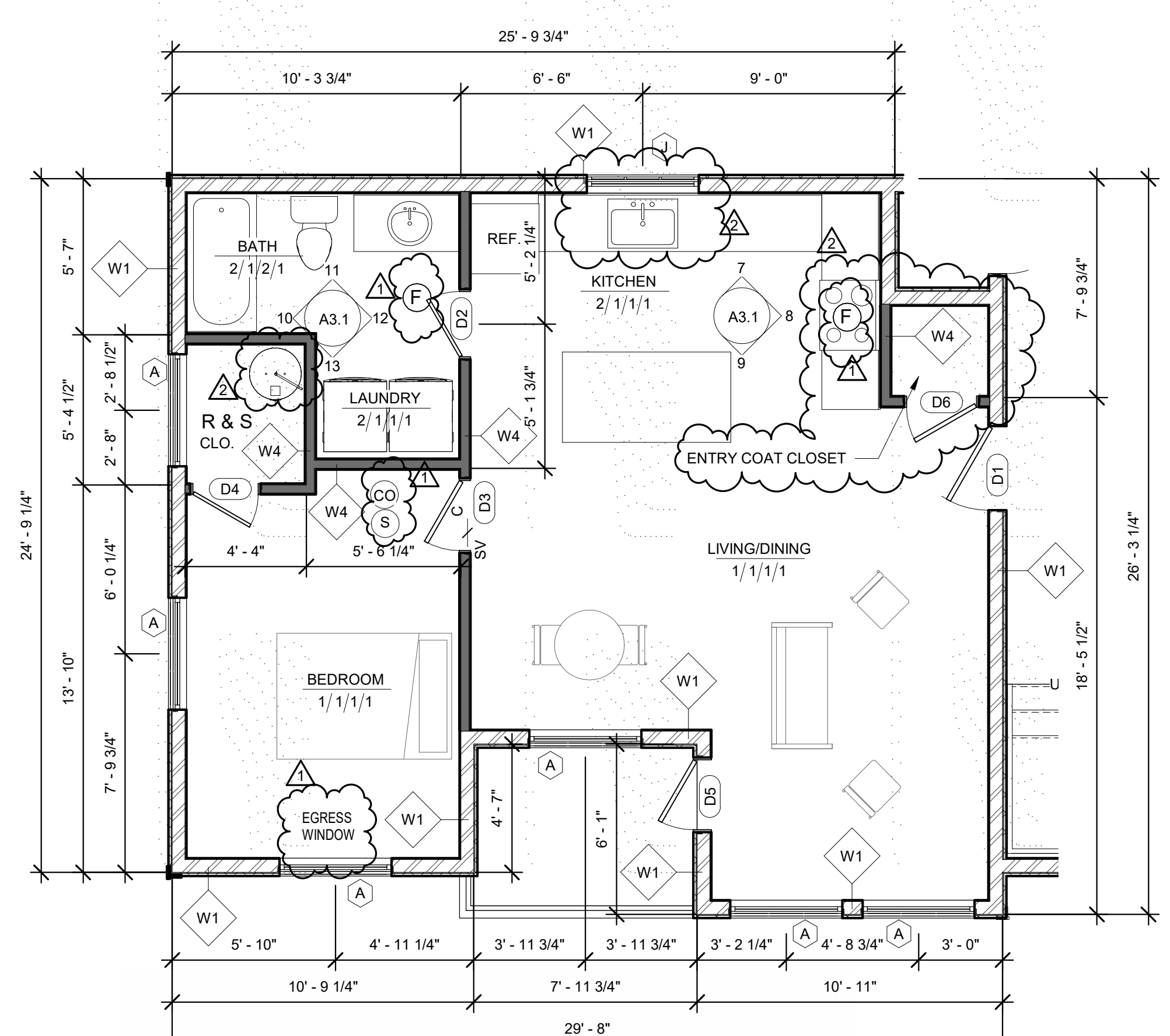

**B** UNIT TYPE D ONE BEDROOM  
1/4" = 1'-0"

**FINISH SCHEDULE**

**FLOOR:**  
1. CARPET (C)  
2. SHEET VINYL (SV)  
3. CONCRETE SEALED (CONC)

**BASE:**  
1. RUBBER BASE  
2. NO BASE

**WALLS:**  
1. PAINTED GWB  
2. PAINTED WATER RESISTANT GWB  
3. UNPAINTED GWB  
FIRE TAP GWB  
NO TEXTURE  
NO PAINT  
AND/OR CONCRETE

**CEILING:**  
1. PAINTED GWB  
2. UNPAINTED GWB  
3. NONE

**KEY: ROOM NAME**  
X / X / X / X

**LEGEND:**  
CO CARBON MONOXIDE DETECTOR  
S SMOKE DETECTOR  
\*\* COMBO DETECTOR IS ALLOWED

**FLOOR PLAN NOTES:**

- ALL EXTERIOR WALLS SHALL BE W1 or W3 U.N.O.
- ALL PARTY WALLS SHALL BE W2 U.N.O.
- SEE SHEET A0.1 FOR ACCESSIBLE DETAIL REQUIREMENTS.
- DIMENSIONS ARE TO STUD OR GRID LINE U.N.O.
- WINDOWS ARE DIMENSIONED TO CENTERLINE U.N.O.
- DOOR JAMBS ARE 4" FROM CORNER U.N.O.
- SEE SHEETS A7.0 FOR DOOR DETAILS AND SCHEDULE
- SEE SHEETS A7.0 FOR WINDOW DETAILS AND SCHEDULE
- TOILETS IN ADA UNITS ARE TO BE LOCATED MIN 18" CLEAR FROM THE CENTERLINE TO ANY OBSTRUCTION.
- CLOSETS SHALL HAVE THE SAME FINISHES AS THE CONNECTING ROOM, U.N.O.
- WASHER PANS TO BE USED IN ALL UNITS EXCEPT ADA UNITS. ADA UNITS TO HAVE FLOOR DRAINS.
- DIMENSION LUMBER FOR FLOOR FRAMING, TYP.

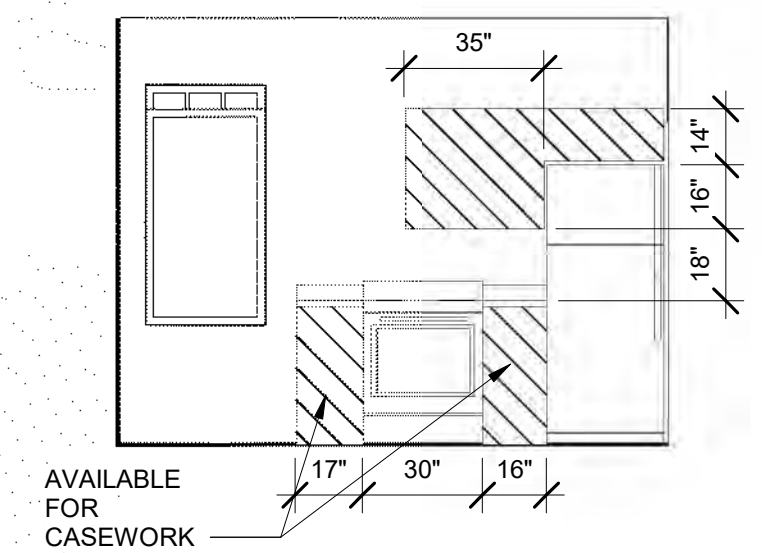

**1** KITCHEN  
1/4" = 1'-0"

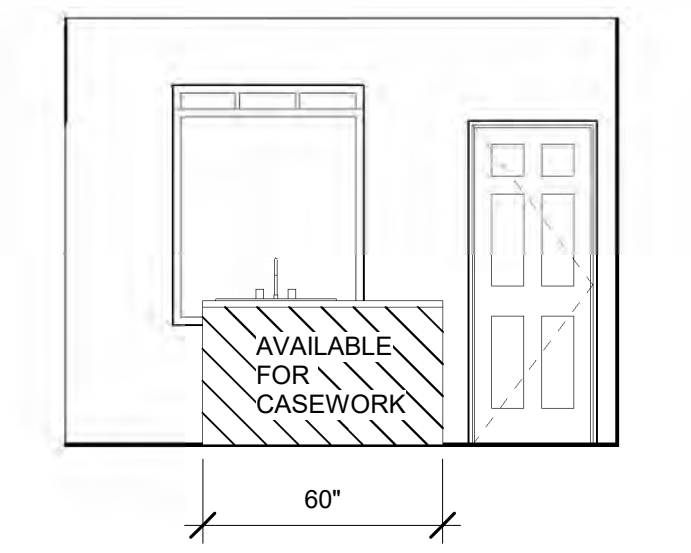

**2** KITCHEN  
1/4" = 1'-0"

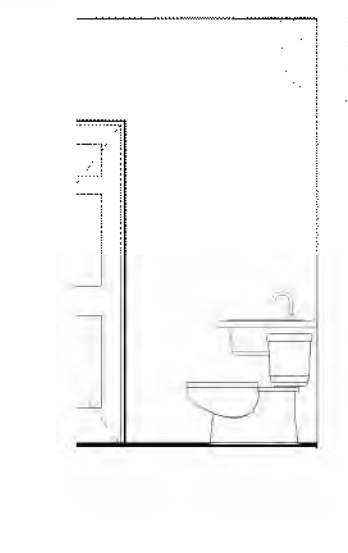

**3** BATH  
1/4" = 1'-0"

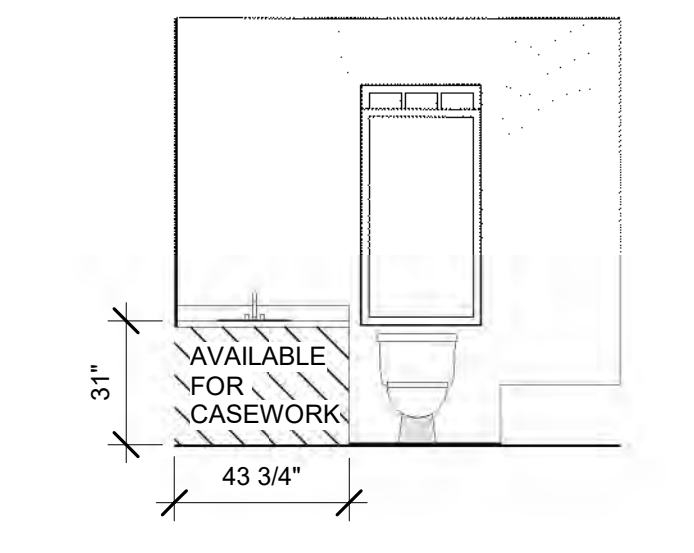

**4** BATH  
1/4" = 1'-0"

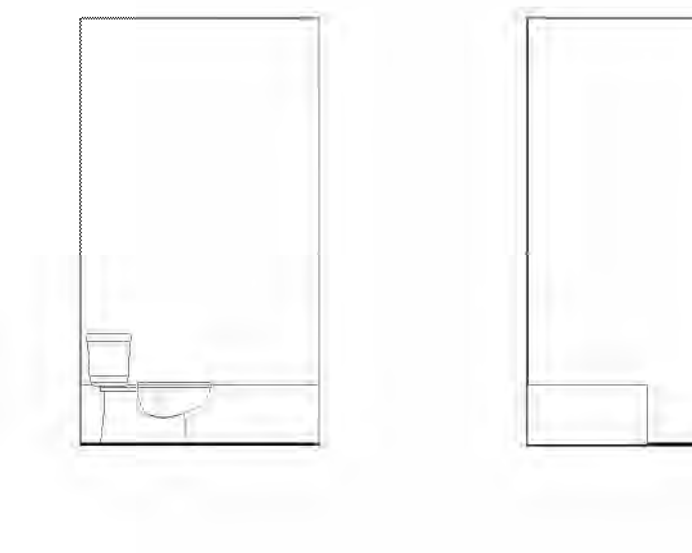

**5** BATH  
1/4" = 1'-0"

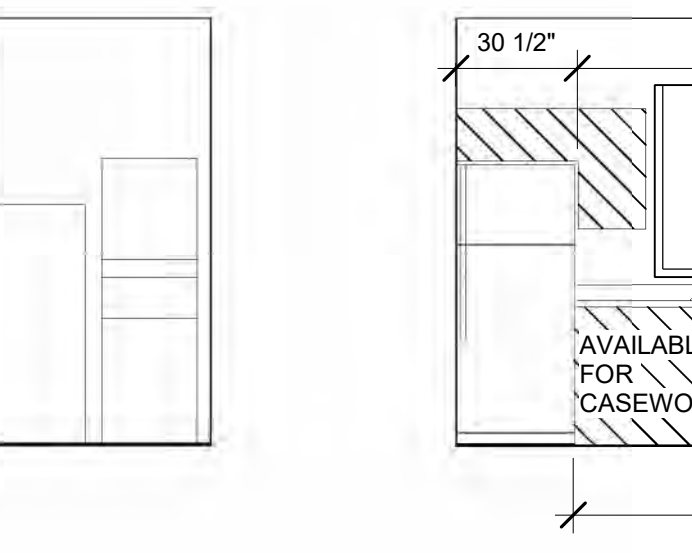

**6** BATH  
1/4" = 1'-0"

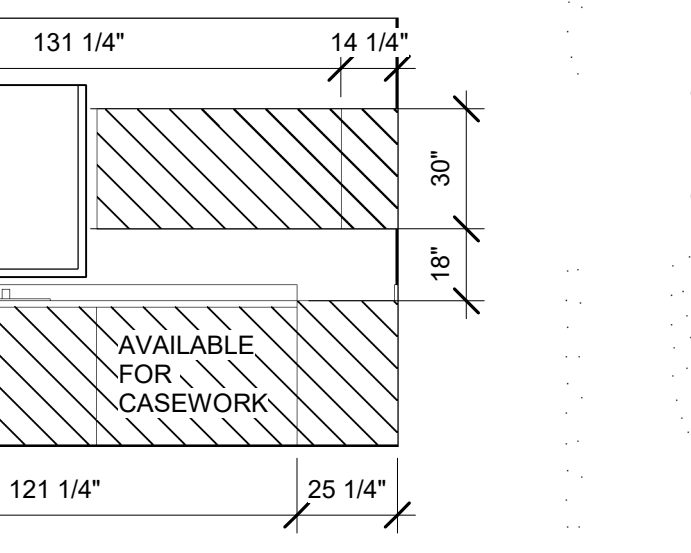

**7** KITCHEN  
1/4" = 1'-0"

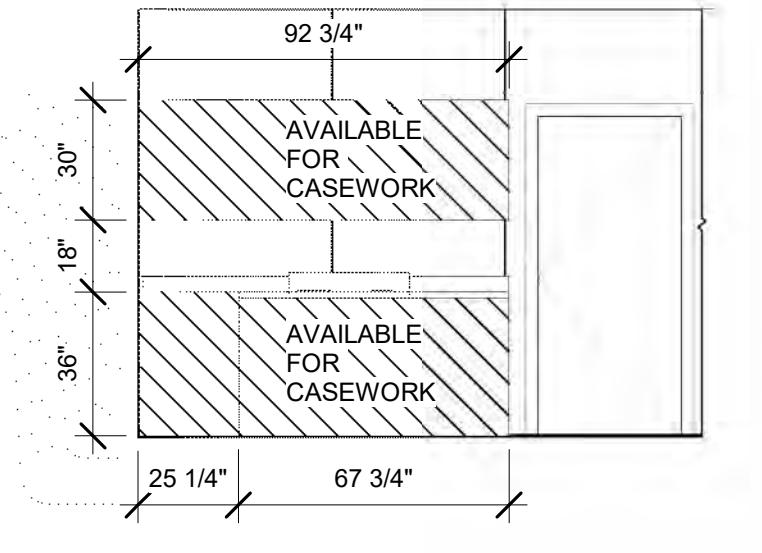

**8** KITCHEN  
1/4" = 1'-0"

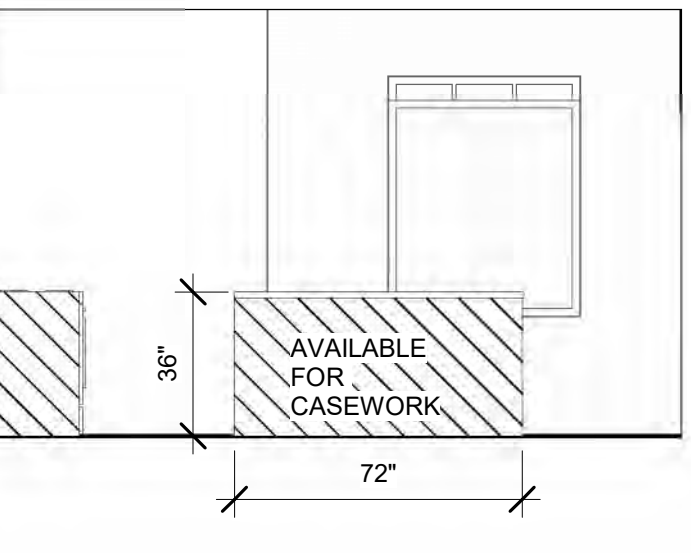

**9** KITCHEN  
1/4" = 1'-0"

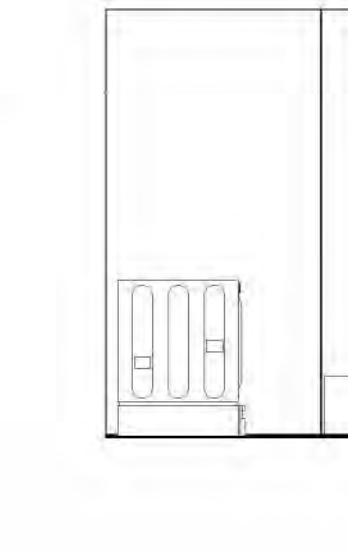

**10** BATH  
1/4" = 1'-0"

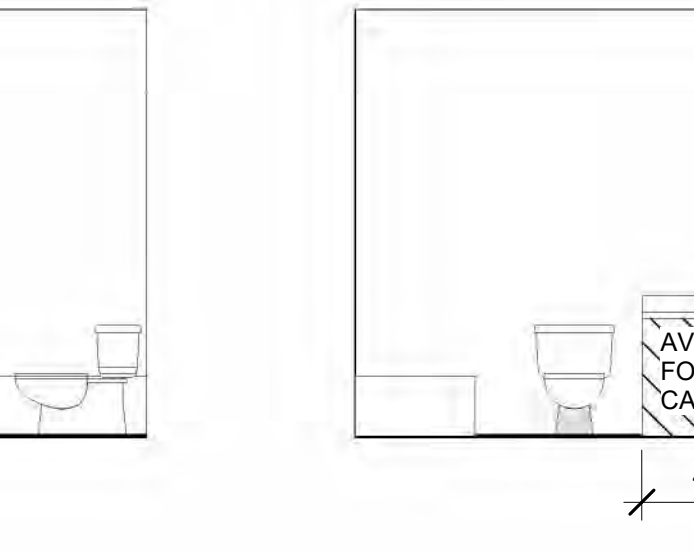

**11** BATH  
1/4" = 1'-0"

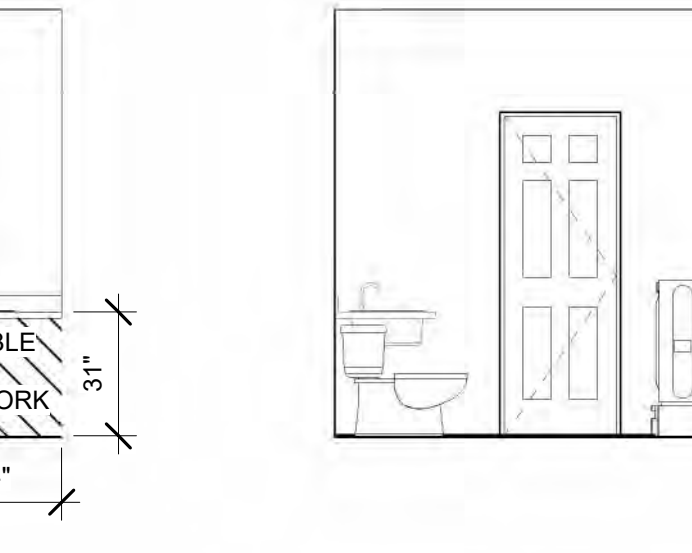

**12** BATH  
1/4" = 1'-0"

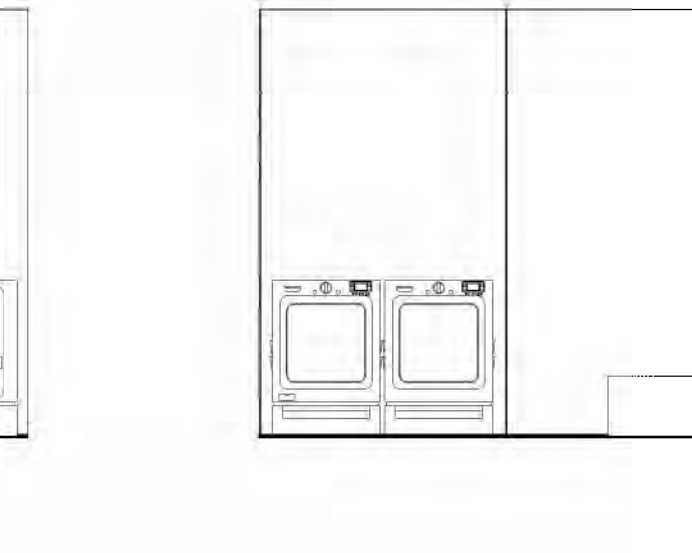

**13** BATH  
1/4" = 1'-0"

**DOOR SCHEDULE UNIT C & D**

| NO. | TYPE | DOOR MAT'L | DOOR FINISH | Width | Height | Thickness | FRAME TYPE | FRAME FINISH | UL RTG | HARDWARE | REMARKS |
|-----|------|------------|-------------|-------|--------|-----------|------------|--------------|--------|----------|---------|
| C1  | A    | WD         | PAINT       | 3'-0" | 6'-8"  | 0'-1 3/4" | METAL      | PAINT        |        |          |         |
| C2  | B    | WD         | PAINT       | 2'-6" | 6'-8"  | 0'-1 3/4" |            | PAINT        |        |          |         |
| C3  | B    | WD         | PAINT       | 2'-6" | 6'-8"  | 0'-1 3/4" |            | PAINT        |        |          |         |
| C4  | B    | WD         | PAINT       | 2'-6" | 6'-8"  | 0'-1 3/4" |            | PAINT        |        |          |         |
| C5  | B    | WD         | PAINT       | 2'-6" | 6'-8"  | 0'-1 3/4" |            | PAINT        |        |          |         |
| D1  | A    | WD         | PAINT       | 3'-0" | 6'-8"  | 0'-1 3/4" | METAL      | PAINT        |        |          |         |
| D2  | B    | WD         | PAINT       | 2'-4" | 6'-8"  | 0'-1 3/8" |            | PAINT        |        |          |         |
| D3  | B    | WD         | PAINT       | 2'-6" | 6'-8"  | 0'-1 3/4" |            | PAINT        |        |          |         |
| D4  | B    | WD         | PAINT       | 2'-4" | 6'-8"  | 0'-1 3/8" |            | PAINT        |        |          |         |
| D5  | B    | WD         | PAINT       | 2'-6" | 6'-8"  | 0'-1 3/4" |            | PAINT        |        |          |         |
| D6  | B    | WD         | PAINT       | 2'-6" | 6'-8"  | 0'-1 3/4" |            | PAINT        |        |          |         |
| D7  | B    | WD         | PAINT       | 2'-6" | 6'-8"  | 0'-1 3/4" |            | PAINT        |        |          |         |
| D8  | B    | WD         | PAINT       | 2'-6" | 6'-8"  | 0'-1 3/4" |            | PAINT        |        |          |         |
| D9  | B    | WD         | PAINT       | 2'-6" | 6'-8"  | 0'-1 3/4" |            | PAINT        |        |          |         |
| D10 | B    | WD         | PAINT       | 2'-6" | 6'-8"  | 0'-1 3/4" |            | PAINT        |        |          |         |
| D11 | B    | WD         | PAINT       | 2'-6" | 6'-8"  | 0'-1 3/4" |            | PAINT        |        |          |         |
| D12 | B    | WD         | PAINT       | 2'-6" | 6'-8"  | 0'-1 3/4" |            | PAINT        |        |          |         |

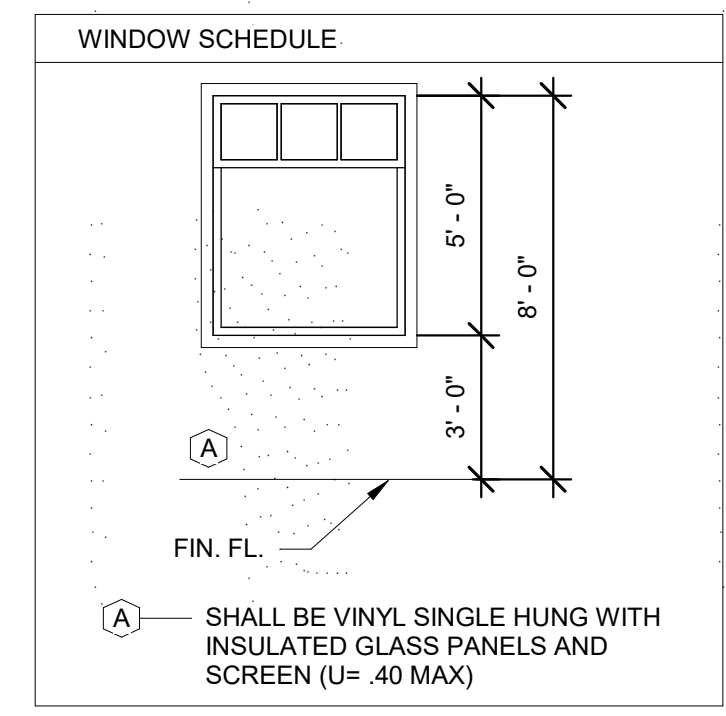
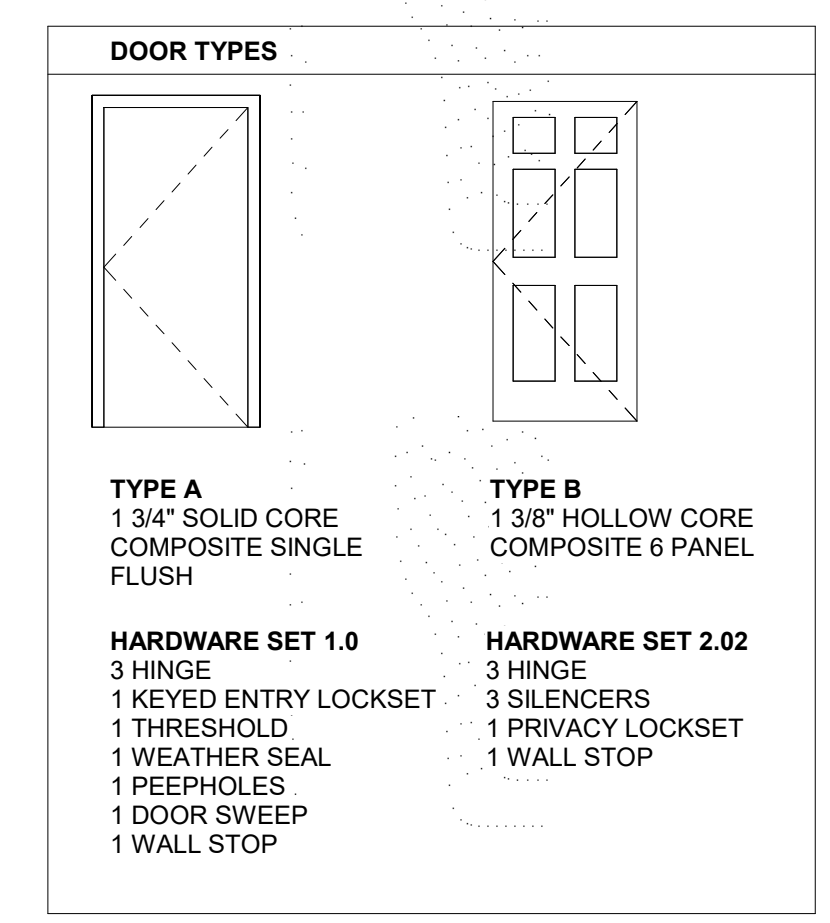

**LJB DESIGNS, LLC**  
111 Market Street N.E., Suite 325  
Olympia, Washington 98501  
(360) 867-1945  
E-mail: LJBDesigns@Comcast.net

**REVISIONS**

| # | ISSUED               | DATE    |
|---|----------------------|---------|
| 1 | REVISED              | 4/27/20 |
| 2 | REGISTERED ARCHITECT | 4/20/20 |

JOSHUA EARL SMOGRASS  
STATE OF WASHINGTON

**BRISTOL APARTMENTS**  
9615 Bristol Ave SW, Lakewood, WA

**ENLARGED UNIT C & UNIT D PLAN**

**A3.1**





1910 EAST 4TH AVENUE PMB #170  
OLYMPIA, WA 98506  
PHONE: 360-528-0513  
JOSH@REVIVALARCHITECTS.COM

LJB DESIGNS, LLC  
111 Market Street N.E., Suite 325  
Olympia, Washington 98501  
(360) 867-1945  
E-mail: LJBDesigns@Comcast.net

| REVISIONS |        |      |
|-----------|--------|------|
| #         | ISSUED | DATE |
|           |        |      |



**1 SOUTH ELEVATION**  
Scale: 1/4" = 1'-0"



**2 WEST ELEVATION**  
Scale: 1/4" = 1'-0"

BRISTOL APARTMENTS  
9615 Bristol Ave SW, Lakewood, WA

EXTERIOR ELEVATIONS

A4.0





1910 EAST 4TH AVENUE PMB #170  
OLYMPIA, WA 98506  
PHONE: 360-528-0513  
JOSH@REVIVALARCHITECTS.COM

LJB DESIGNS, LLC  
111 Market Street N.E., Suite 325  
Olympia, Washington 98501  
(360) 867-1945  
E-mail: LJBDesigns@Comcast.net

| REVISIONS |        |      |
|-----------|--------|------|
| #         | ISSUED | DATE |
|           |        |      |

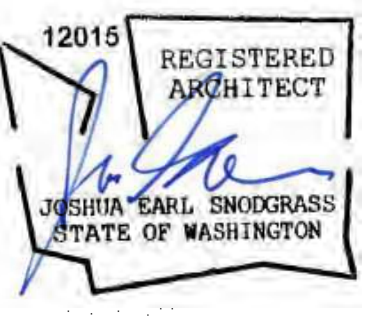

ANTIQUE BLACK  
ARCHITECTURAL SHINGLES

FASCIA BOARDS: SHERWIN  
WILLIAMS TRICORN BLACK  
6258

LAP SIDING: BEHR PPU 25-12  
MINIMALISTIC MINE

FASCIA BOARDS: SHERWIN  
WILLIAMS TRICORN BLACK  
6258

LAP SIDING: SHERWIN  
WILLIAMS GRAPY 7629

3 NORTH ELEVATION  
Scale: 1/4" = 1'-0"

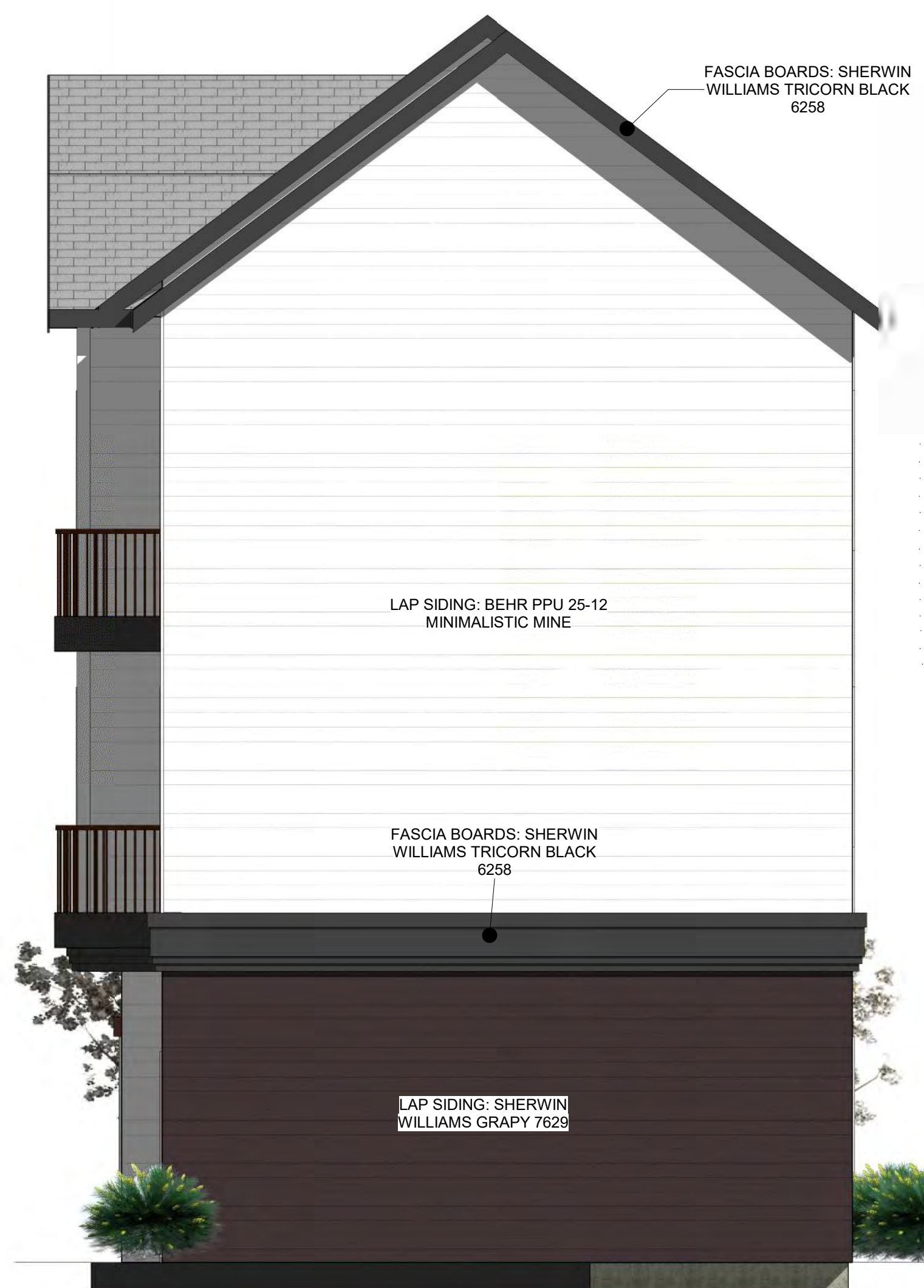

FASCIA BOARDS: SHERWIN  
WILLIAMS TRICORN BLACK  
6258

LAP SIDING: BEHR PPU 25-12  
MINIMALISTIC MINE

FASCIA BOARDS: SHERWIN  
WILLIAMS TRICORN BLACK  
6258

LAP SIDING: SHERWIN  
WILLIAMS GRAPY 7629

4 EAST ELEVATION  
Scale: 1/4" = 1'-0"

BRISTOL APARTMENTS  
9615 Bristol Ave SW, Lakewood, WA

EXTERIOR  
ELEVATION





1910 EAST 4TH AVENUE PMB #170  
OLYMPIA, WA 98506  
PHONE: 360-528-0513  
JOSH@REVIVALARCHITECTS.COM

**LJB DESIGNS, LLC**  
111 Market Street N.E., Suite 325  
Olympia, Washington 98501  
(360) 867-1945  
E-mail: LJBDesigns@Comcast.net

| REVISIONS |                      |      |
|-----------|----------------------|------|
| #         | ISSUED               | DATE |
| 12015     | REGISTERED ARCHITECT |      |

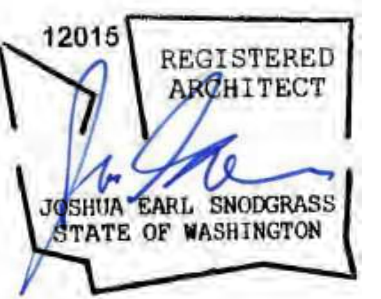

718.4.2 GROUPS R-1 AND R-2. DRAFTSTOPPING SHALL BE PROVIDED IN ATTICS, MANSARDS, OVERHANGS OR OTHER CONCEALED ROOF SPACES OF GROUP R-2 BUILDINGS WITH THREE OR MORE DWELLING UNITS AND IN ALL GROUP R-1 BUILDINGS. DRAFTSTOPPING SHALL BE INSTALLED ABOVE, AND IN LINE WITH, SLEEPING UNIT AND DWELLING UNIT SEPARATION WALLS THAT DO NOT EXTEND TO THE UNDERSIDE OF THE ROOF SHEATHING ABOVE.

- EXCEPTIONS:**
1. WHERE CORRIDOR WALLS PROVIDE A SLEEPING UNIT OR DWELLING UNIT SEPARATION, DRAFTSTOPPING SHALL ONLY BE REQUIRED ABOVE ONE OF THE CORRIDOR WALLS.
  2. DRAFTSTOPPING IS NOT REQUIRED IN BUILDINGS EQUIPPED THROUGHOUT WITH AN AUTOMATIC SPRINKLER SYSTEM IN ACCORDANCE WITH SECTION 903.3.1.1.
  3. IN OCCUPANCIES IN GROUP R-2 THAT DO NOT EXCEED FOUR STORIES ABOVE GRADE PLANE, THE ATTIC SPACE SHALL BE SUBDIVIDED BY DRAFTSTOPS INTO AREAS NOT EXCEEDING 3,000 SQUARE FEET (279 M<sup>2</sup>) OR ABOVE EVERY TWO DWELLING UNITS, WHICHEVER IS SMALLER.
  4. DRAFTSTOPPING IS NOT REQUIRED IN BUILDINGS EQUIPPED THROUGHOUT WITH AN AUTOMATIC SPRINKLER SYSTEM IN ACCORDANCE WITH SECTION 903.3.1.2, PROVIDED THAT AUTOMATIC SPRINKLERS ARE INSTALLED IN THE COMBUSTIBLE CONCEALED SPACE WHERE THE DRAFTSTOPPING IS BEING OMITTED.

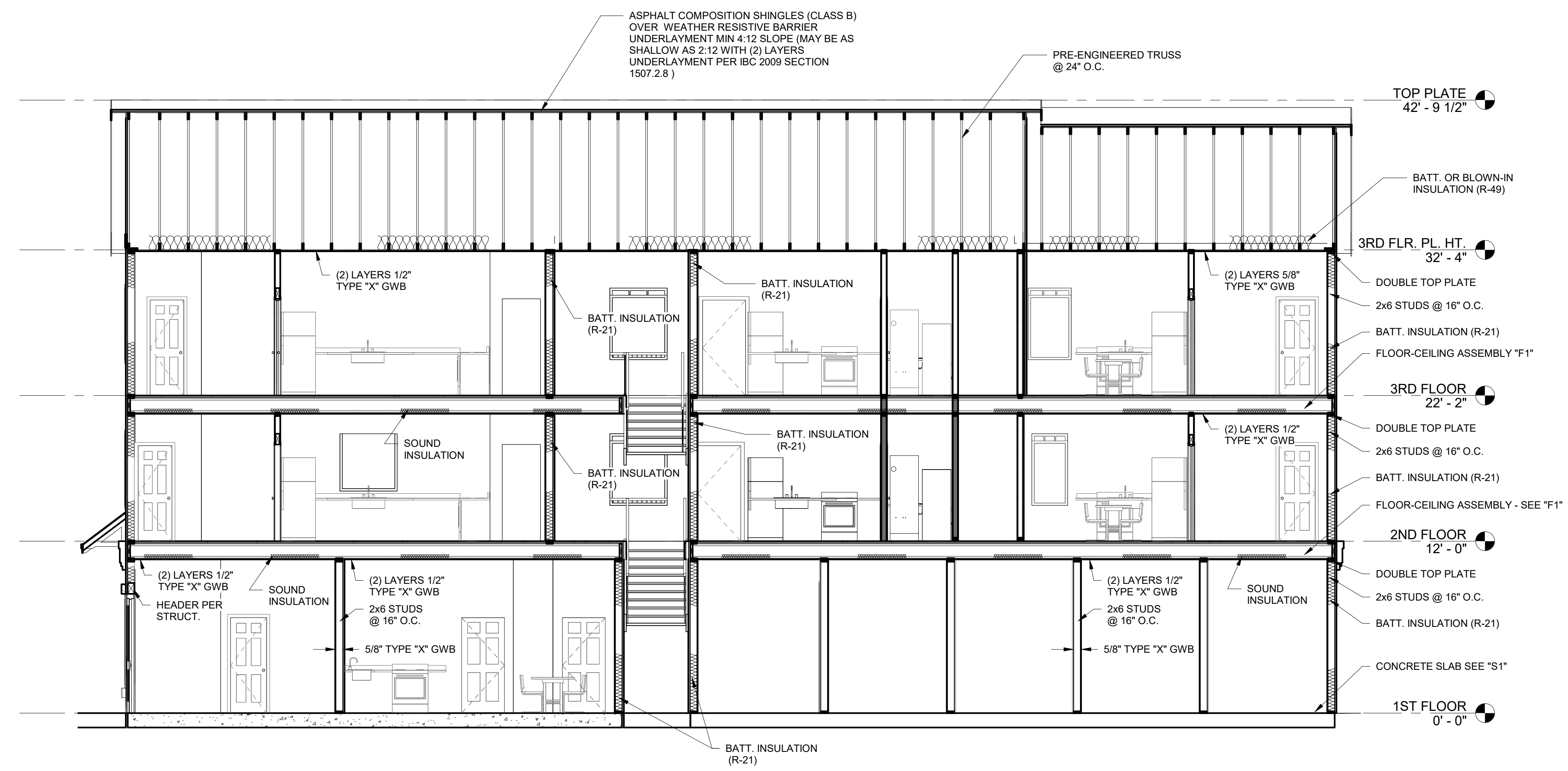

**A BUILDING SECTION**  
3/16" = 1'-0"

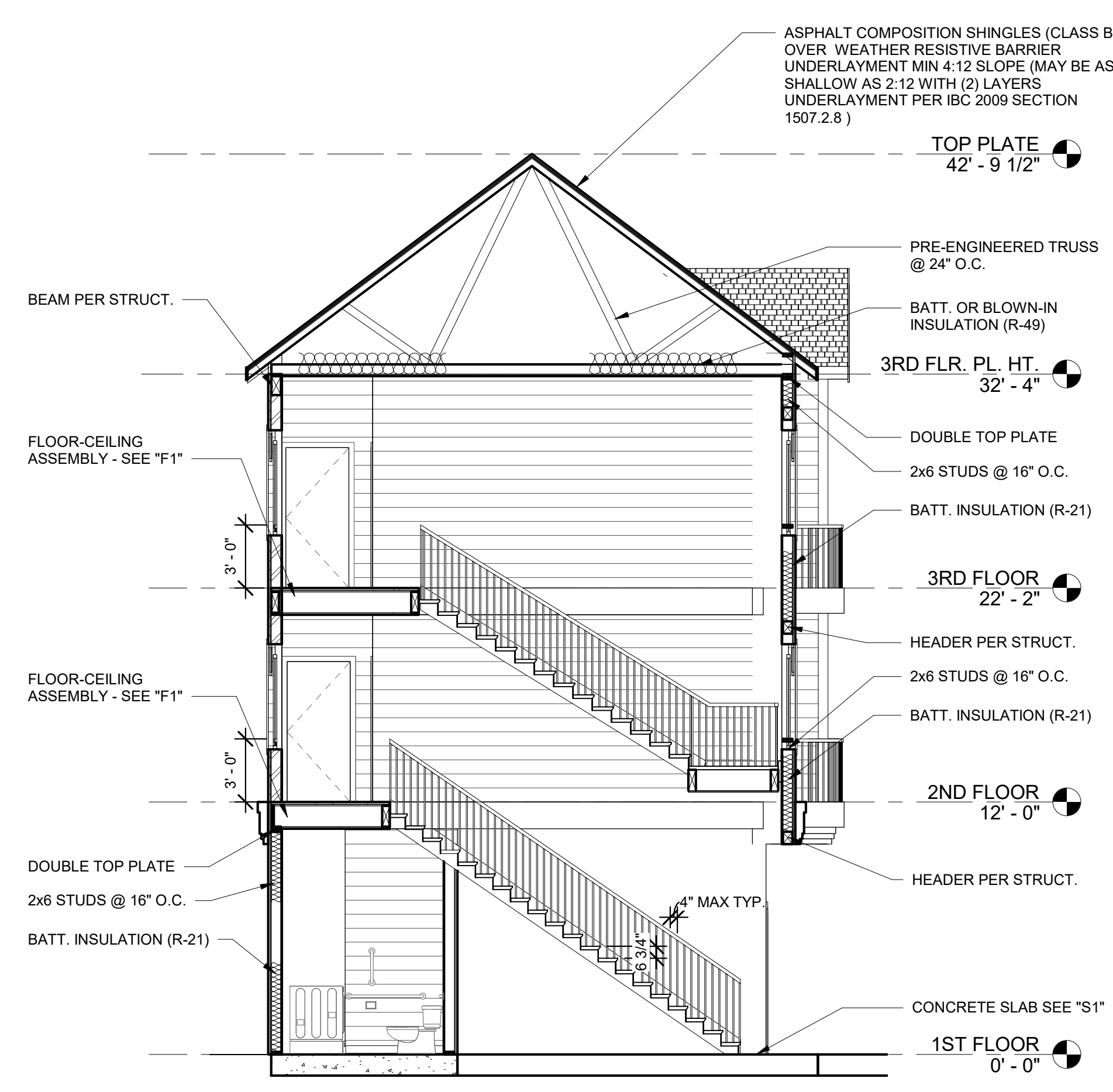

**B BUILDING SECTION**  
3/16" = 1'-0"

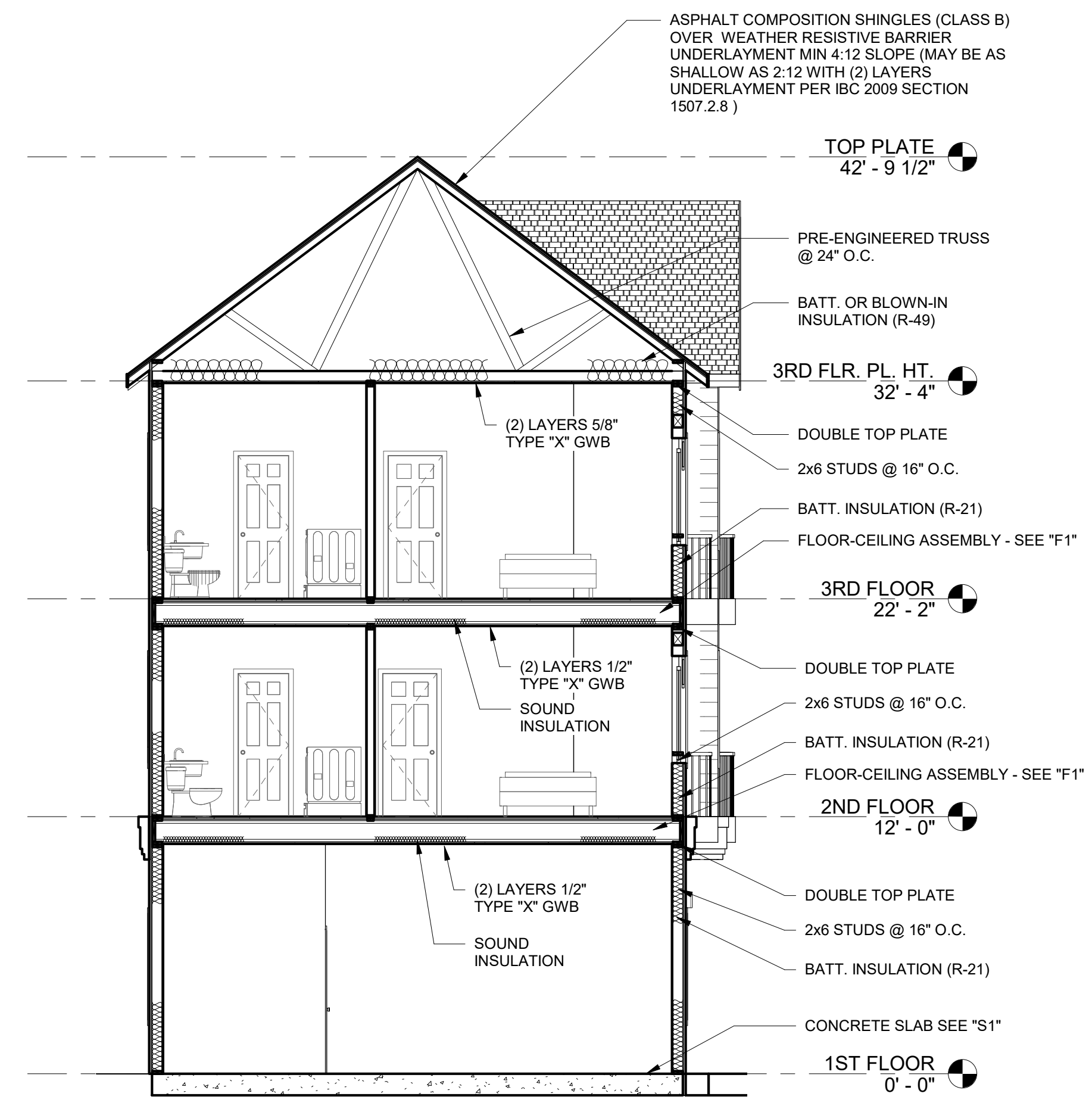

**C BUILDING SECTION**  
3/16" = 1'-0"

**BRISTOL APARTMENTS**  
9615 Bristol Ave SW, Lakewood, WA

**BUILDING SECTIONS**

**A5.0**





LJB DESIGNS, LLC  
111 Market Street N.E., Suite 325  
Olympia, Washington 98501  
(360) 867-1945  
E-mail: LJBDesigns@Comcast.net

| REVISIONS |        |      |
|-----------|--------|------|
| #         | ISSUED | DATE |
|           |        |      |

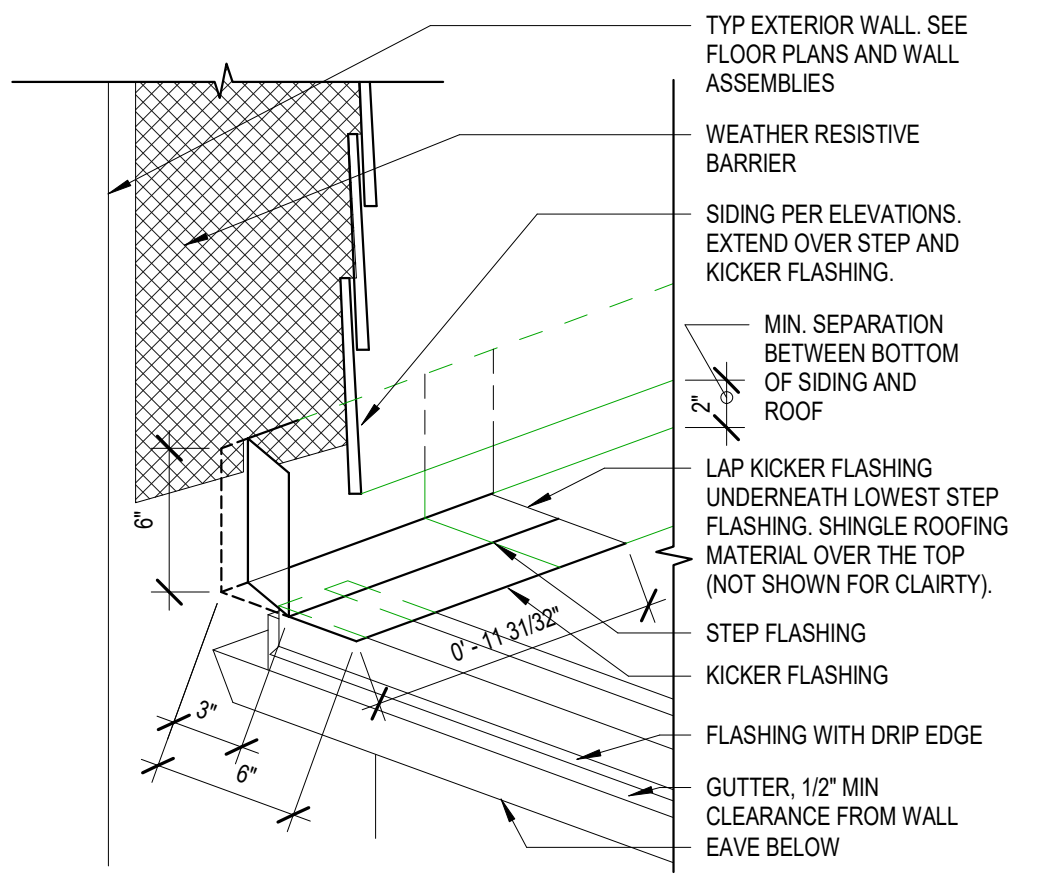
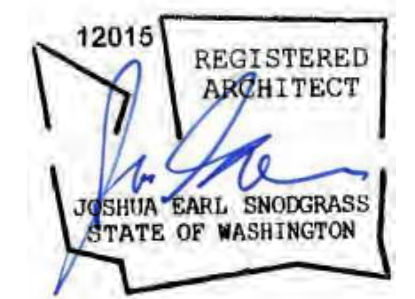

21 ROOF TO WALL KICK OUT FLASHING  
1 1/2" = 1'-0"

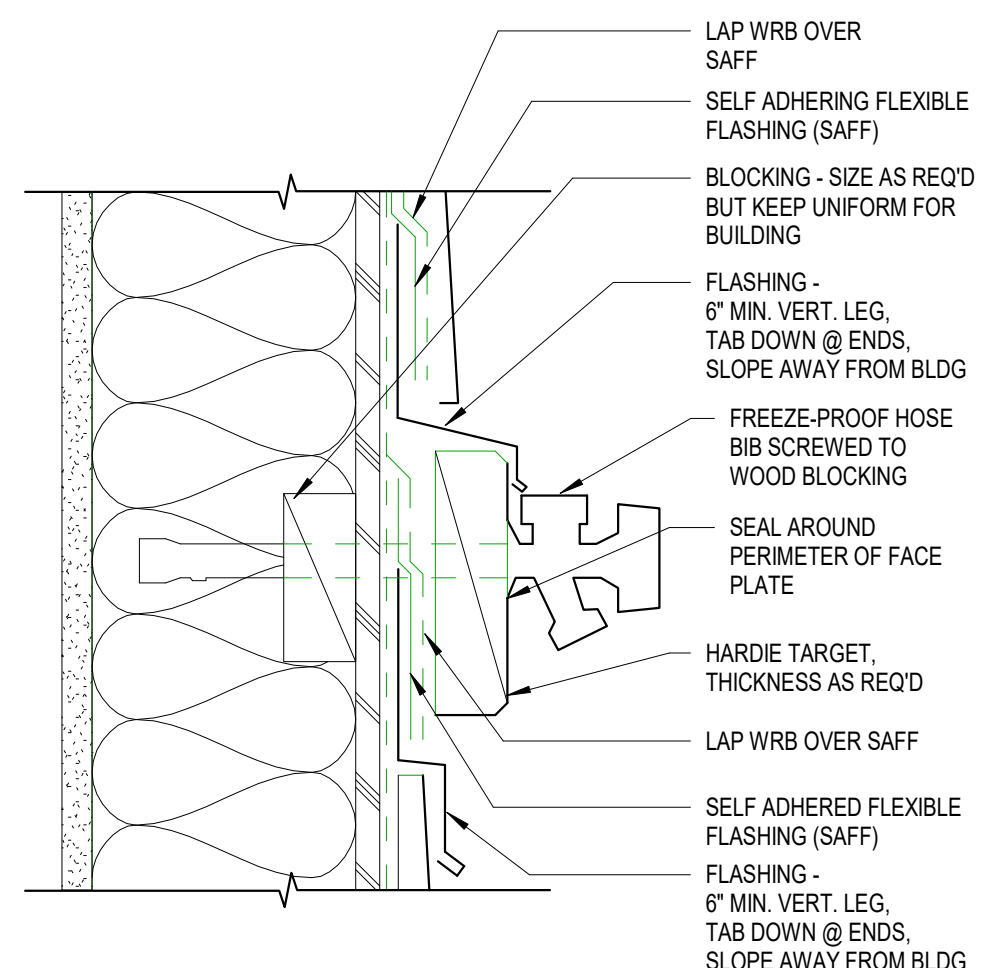

13 HOSE BIBB @ SIDING  
3" = 1'-0"

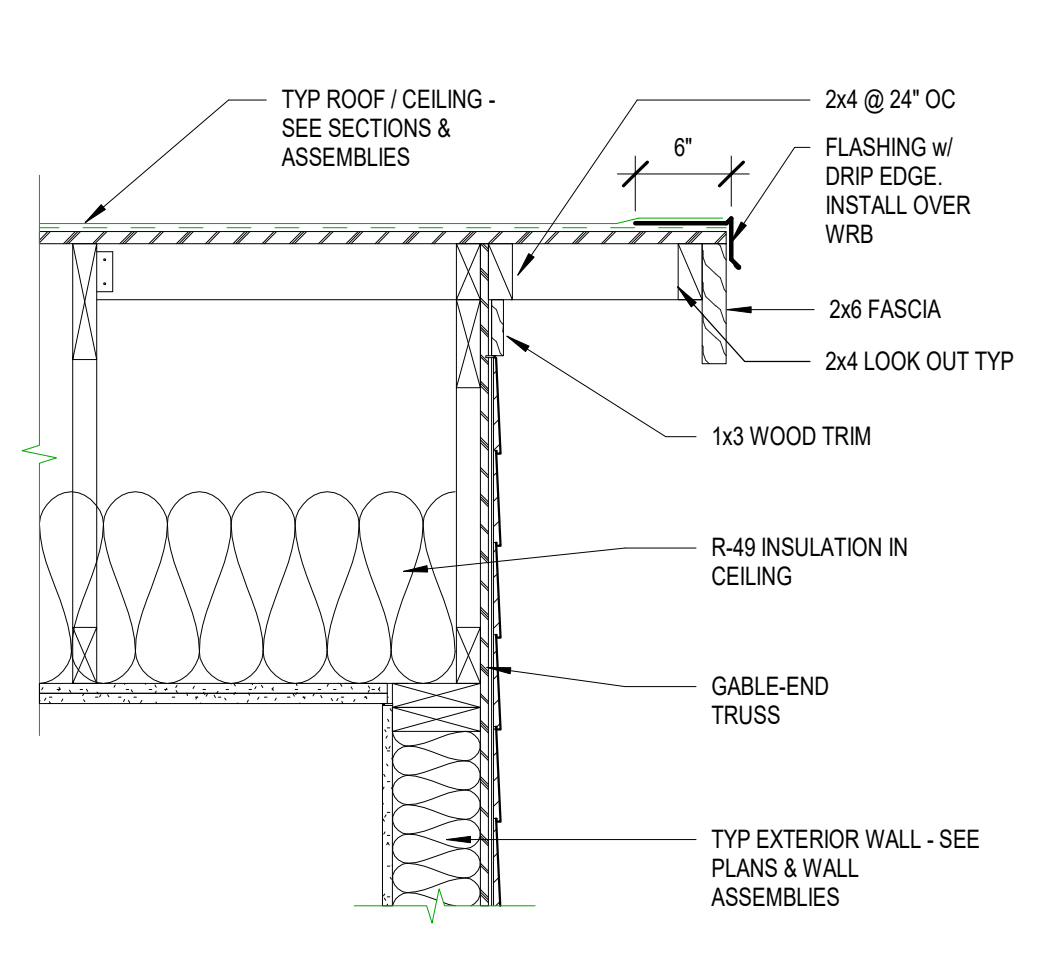

9 TYP GABLE-END OVERHANG DETAIL  
1" = 1'-0"

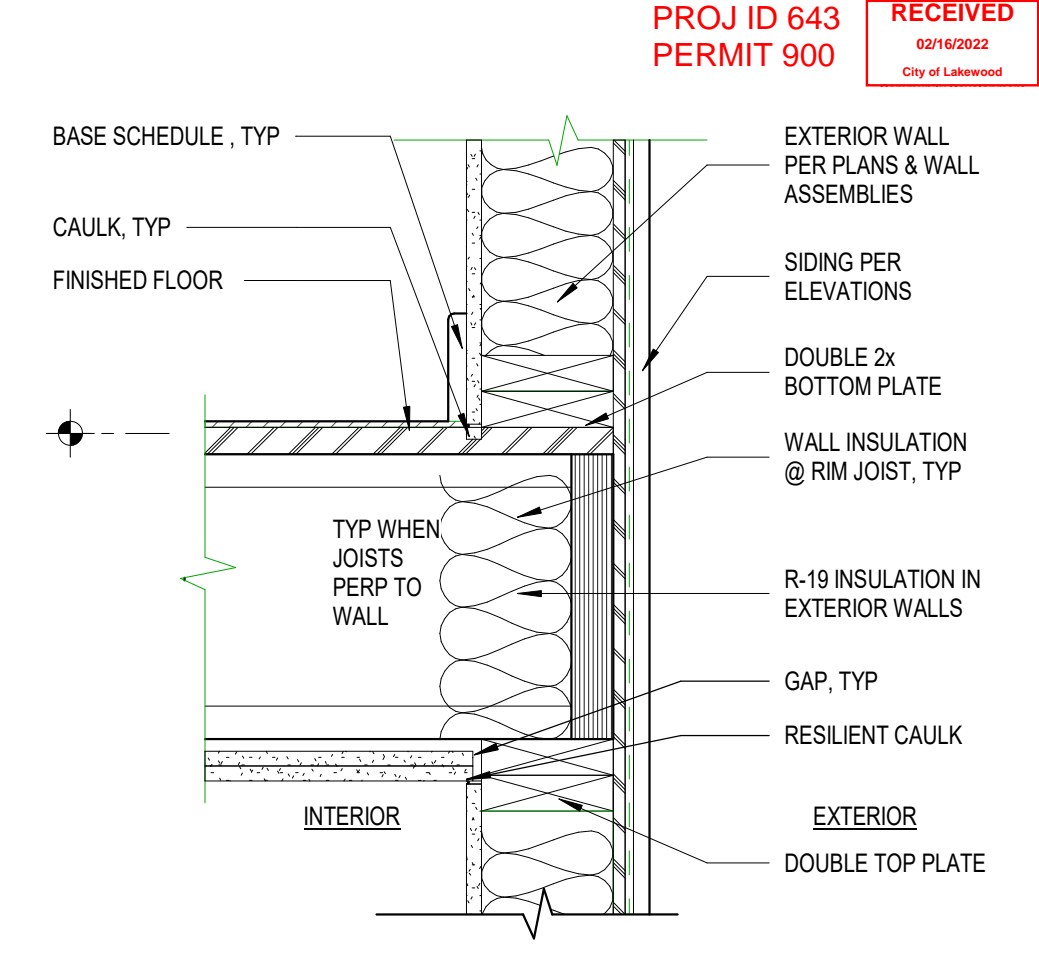

5 TYP APTS EXTERIOR WALL/FLOOR CONNECTION  
1 1/2" = 1'-0"

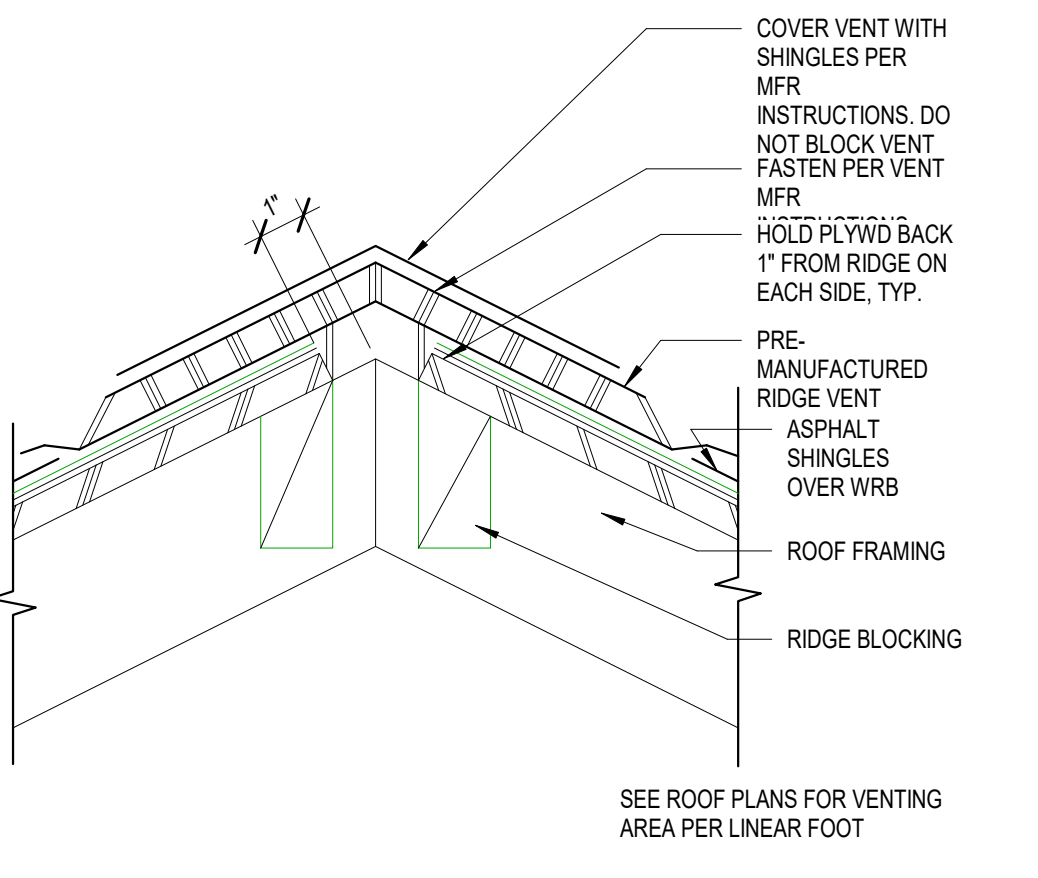

20 RIDGE VENT  
3" = 1'-0"

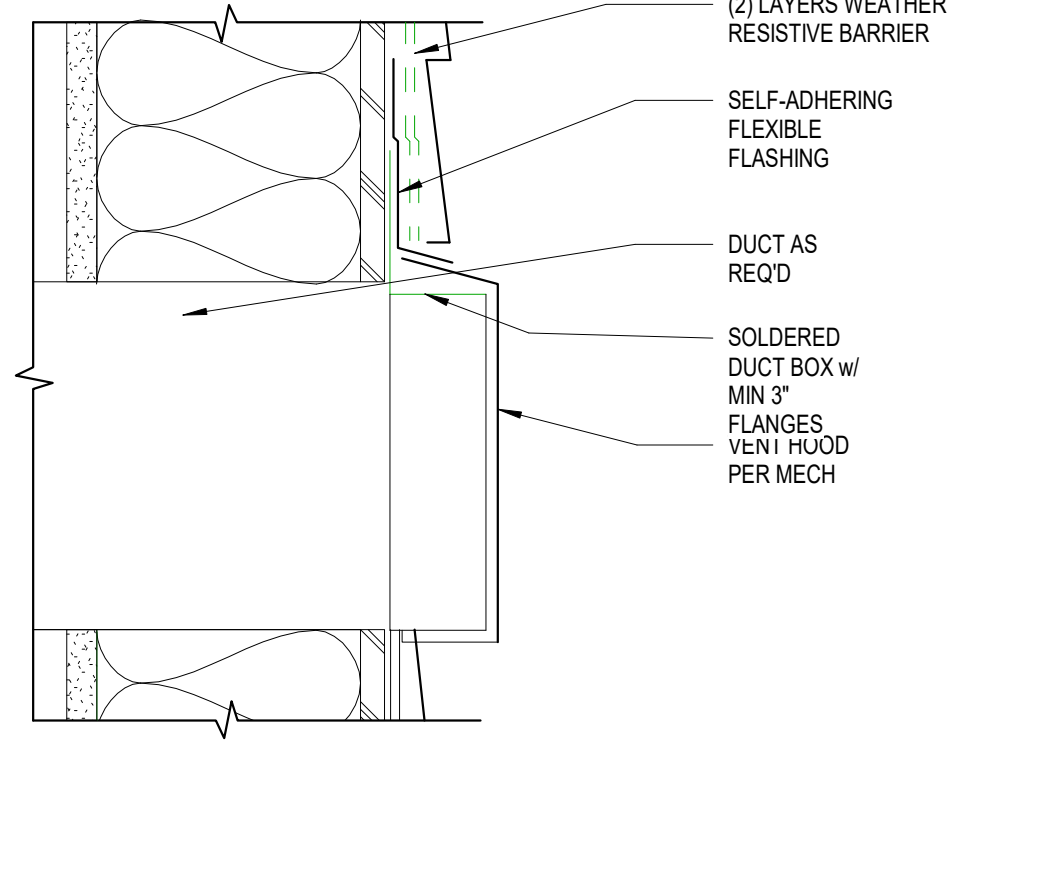

16 TYPICAL VENT PENETRATION  
3" = 1'-0"

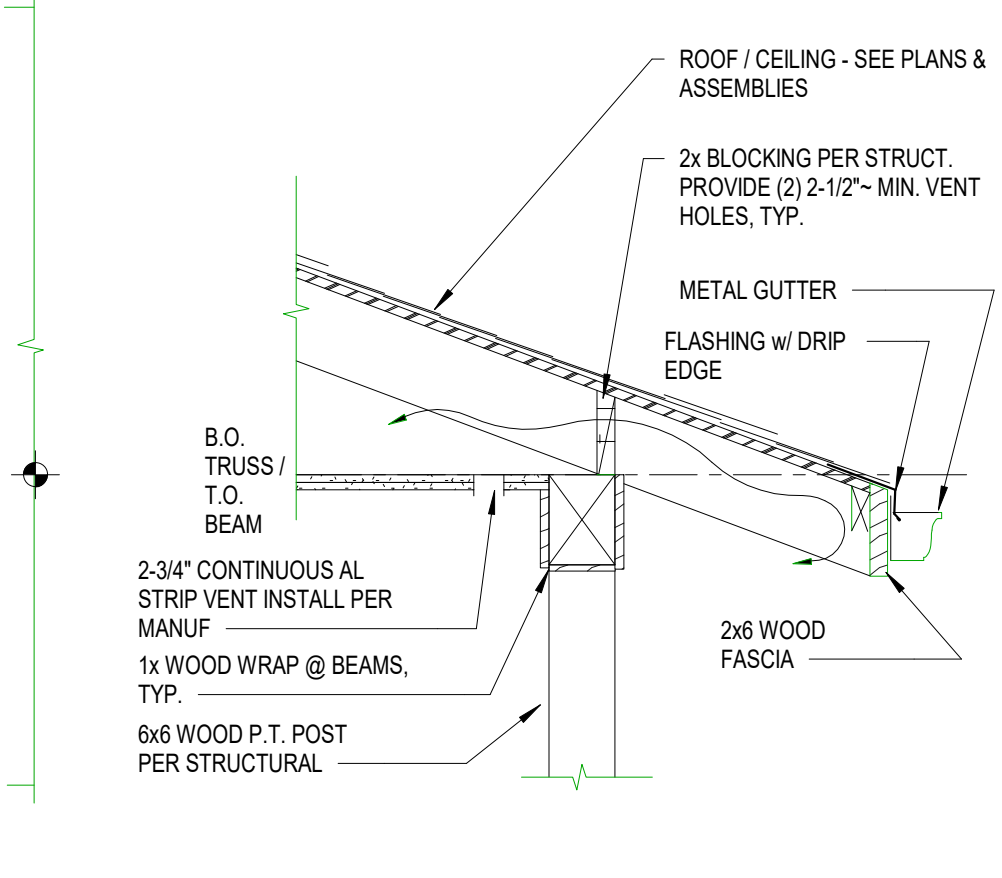

12 PORCH ROOF SECTION - ROOF TO WALL  
3/4" = 1'-0"

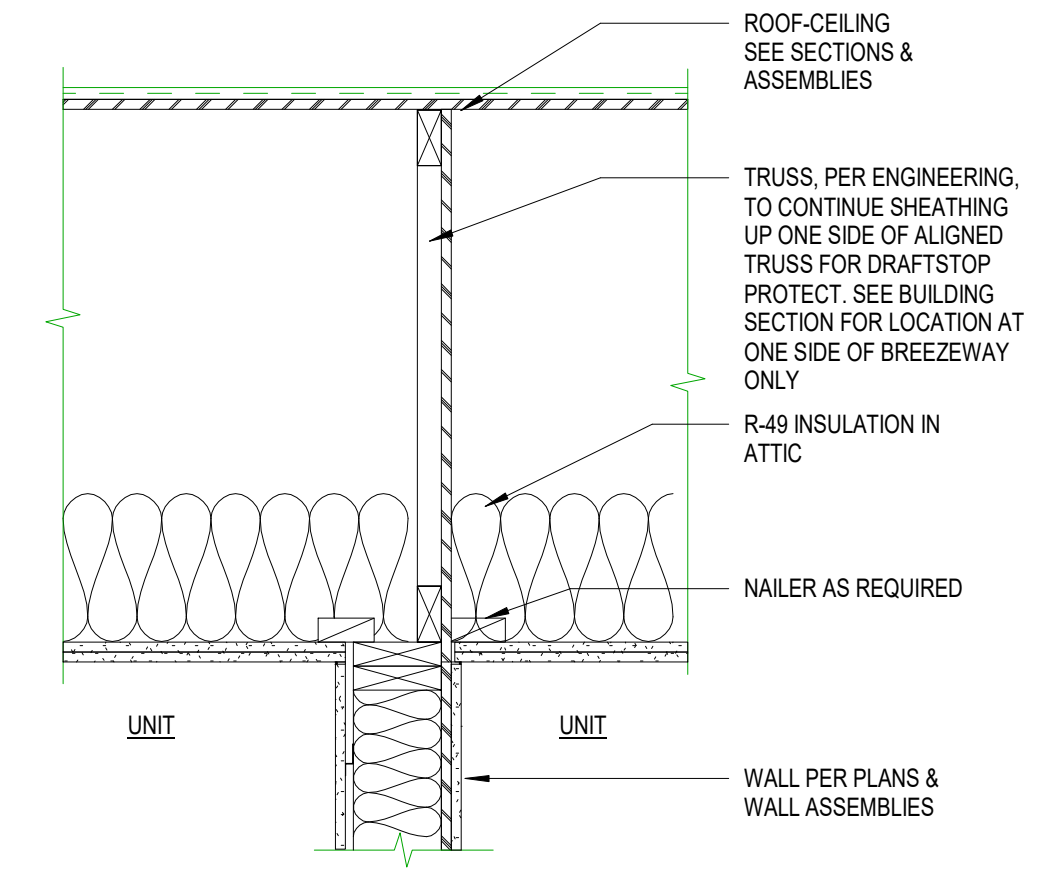

8 PARTY WALL TO ROOF  
1" = 1'-0"

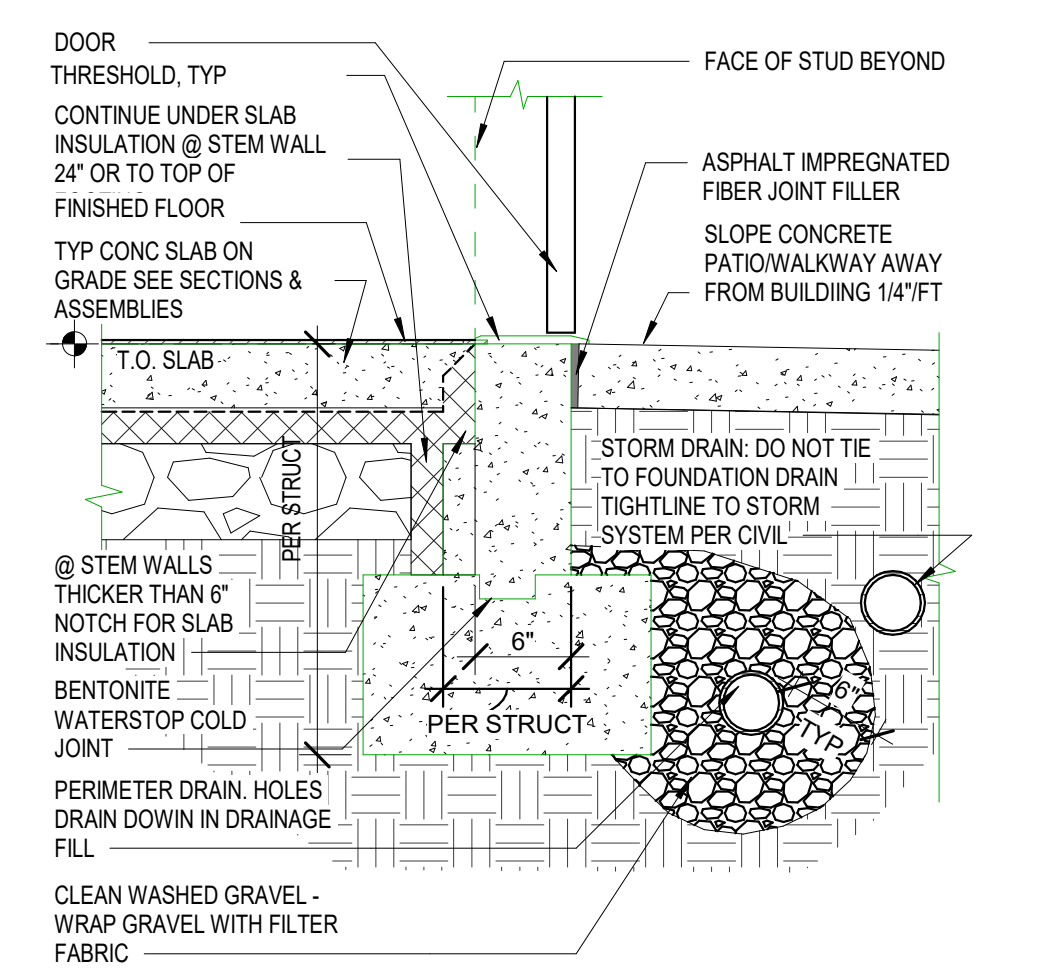

7 TYP FOOTING @ ENTRY THRESHOLD  
1" = 1'-0"

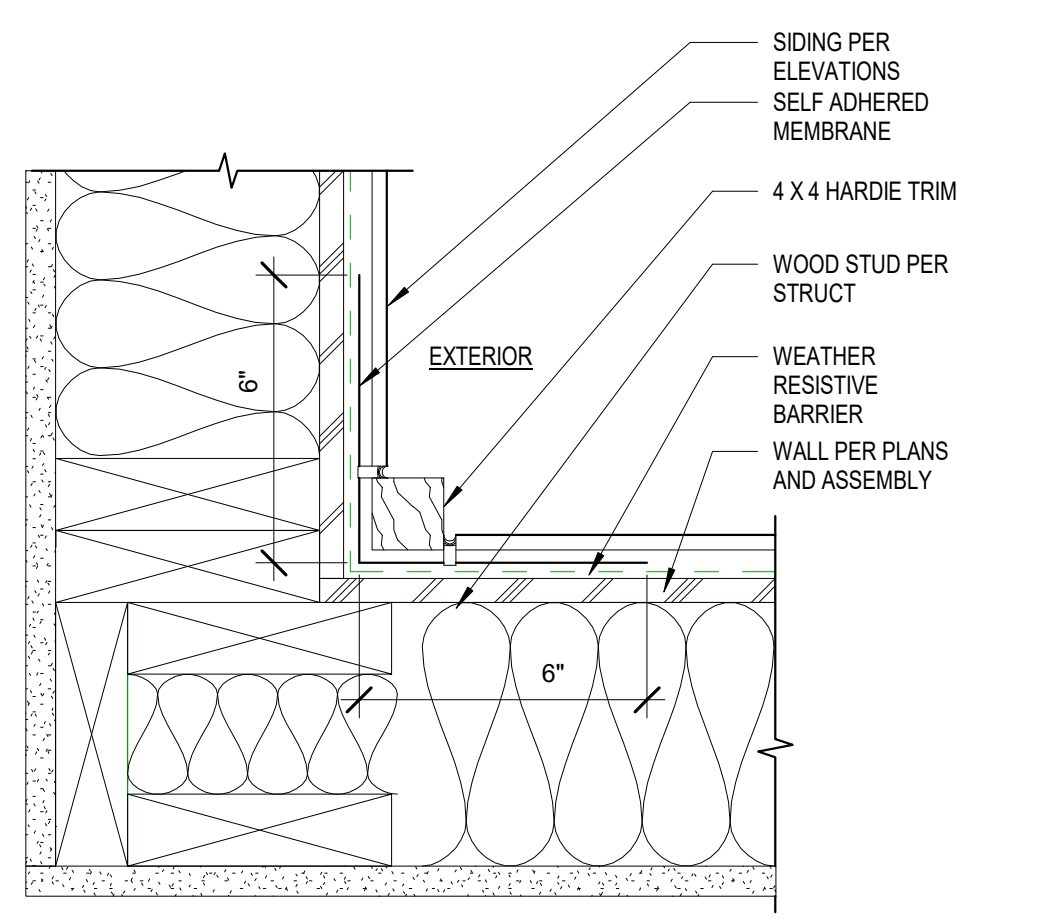

19 SIDING @ INTERNAL CORNER  
3" = 1'-0"

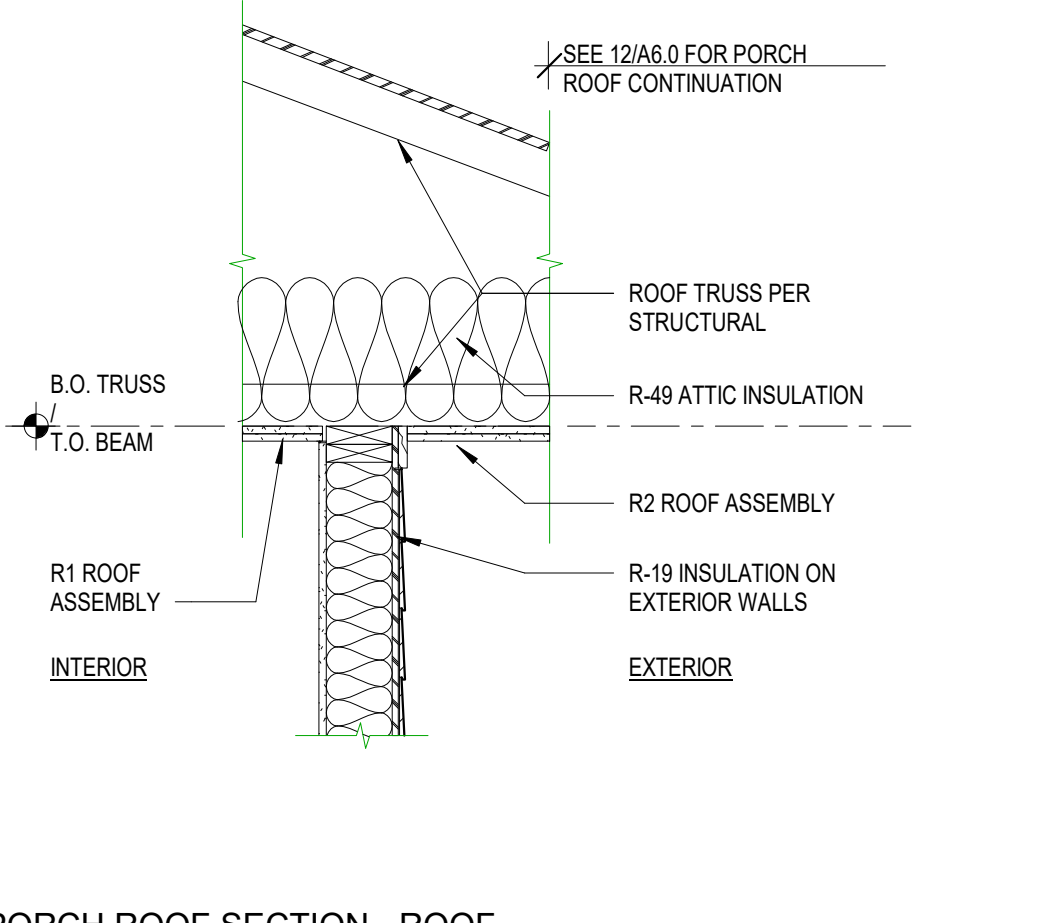

15 PORCH ROOF SECTION - ROOF EXTENDS BEYOND  
3/4" = 1'-0"

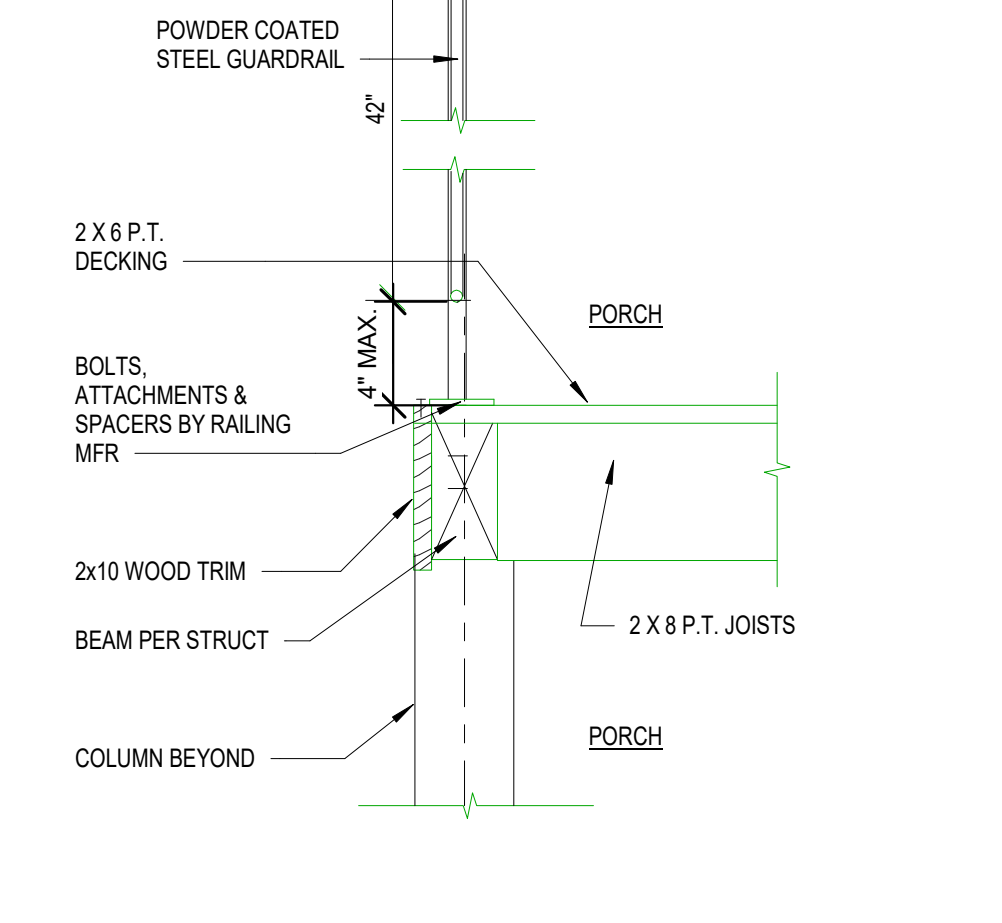

11 RAILING @ PORCH  
3/4" = 1'-0"

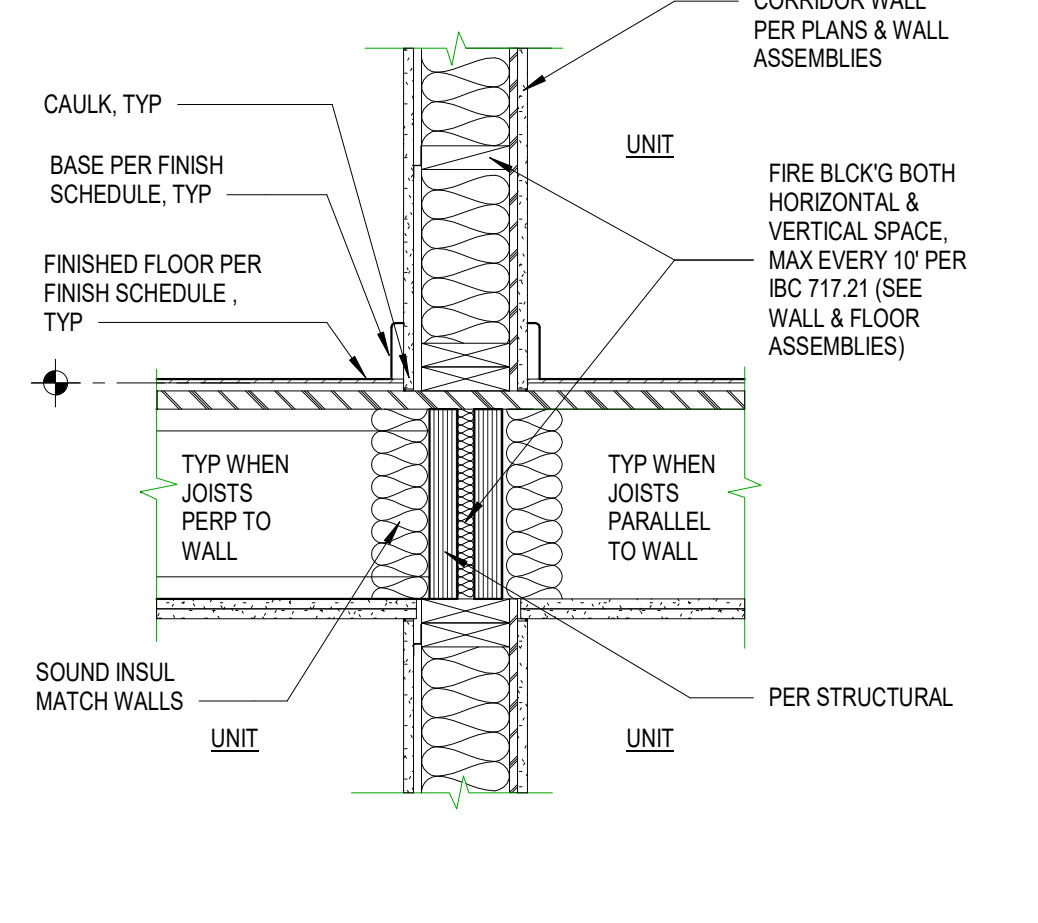

7 PARTY WALL TO FLOOR CONNECTION  
1" = 1'-0"

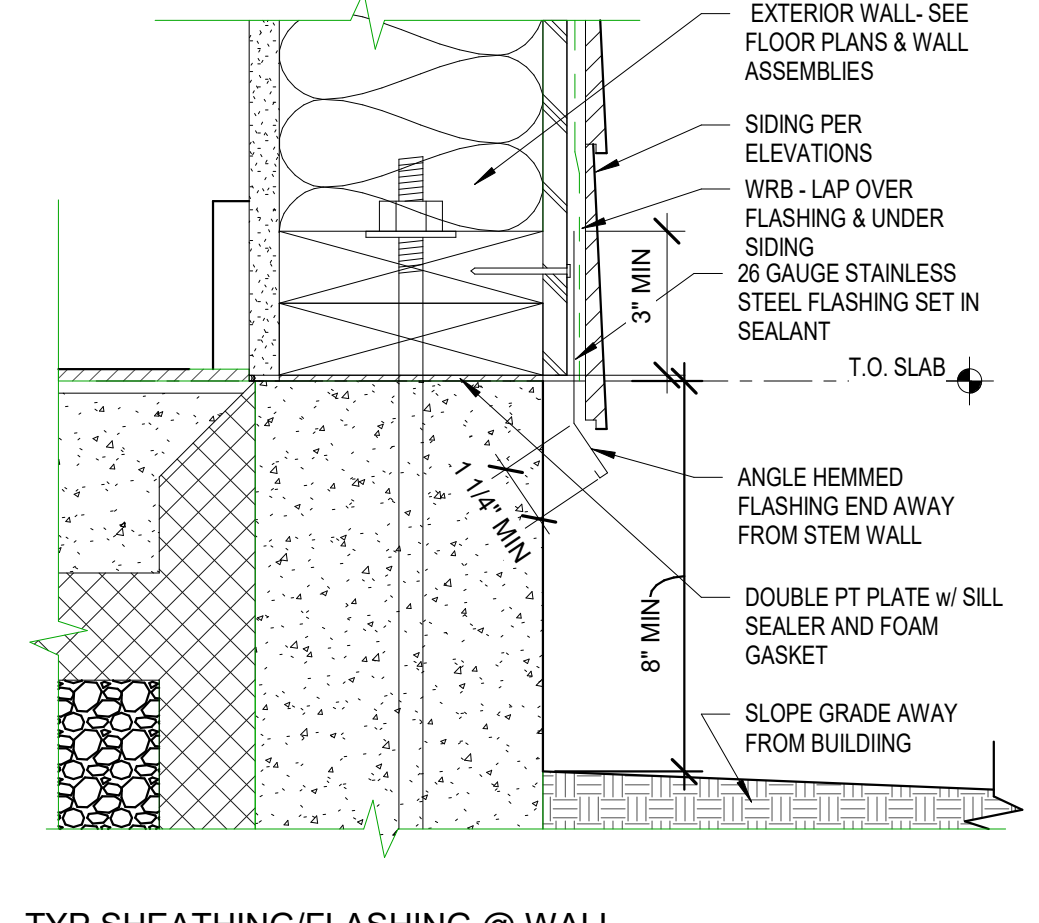

2 TYP SHEATHING/FLASHING @ WALL BASE  
3" = 1'-0"

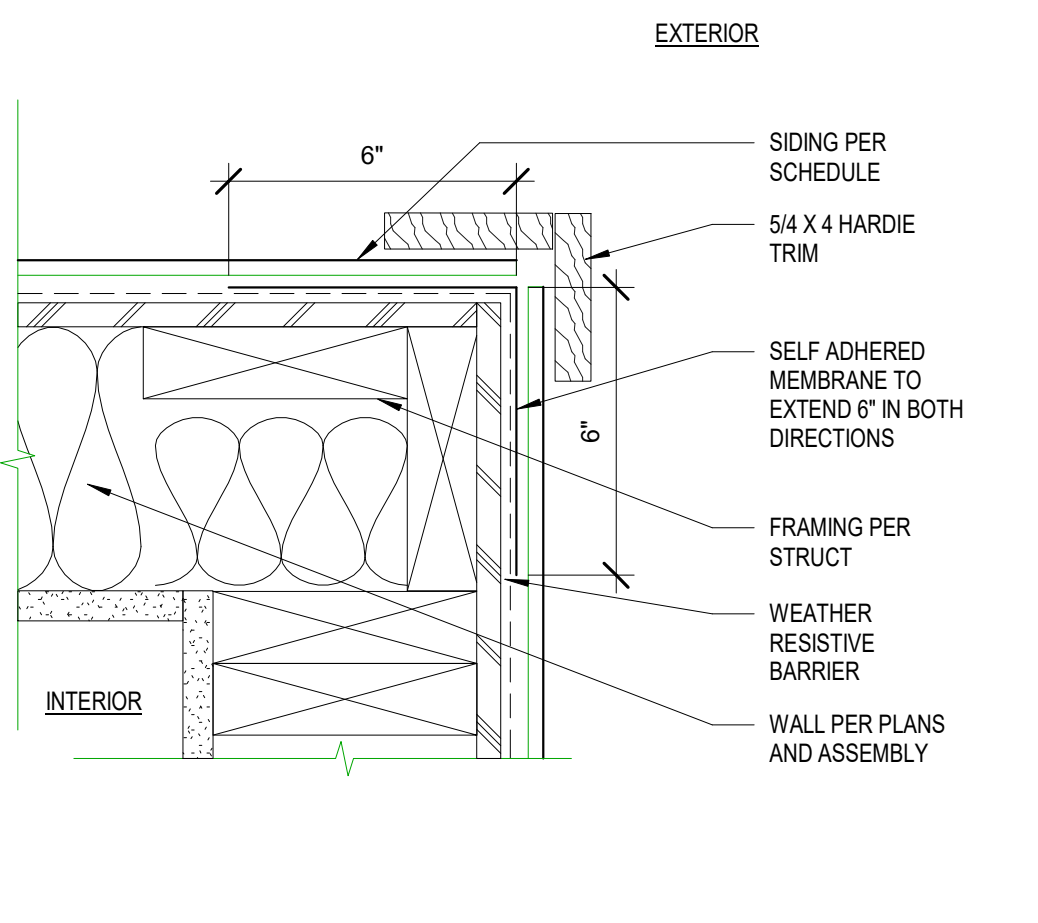

18 SIDING @ EXTERNAL CORNER  
3" = 1'-0"

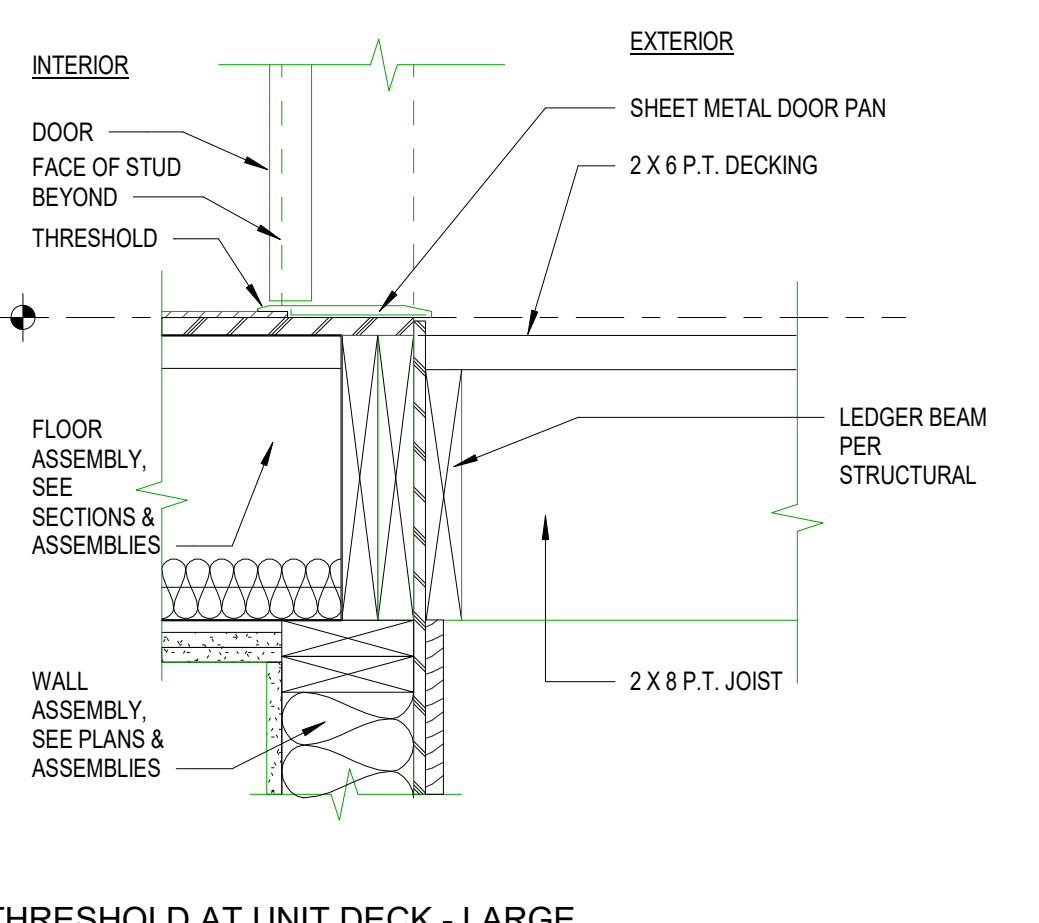

14 THRESHOLD AT UNIT DECK - LARGE (NOT USED)  
1 1/2" = 1'-0"

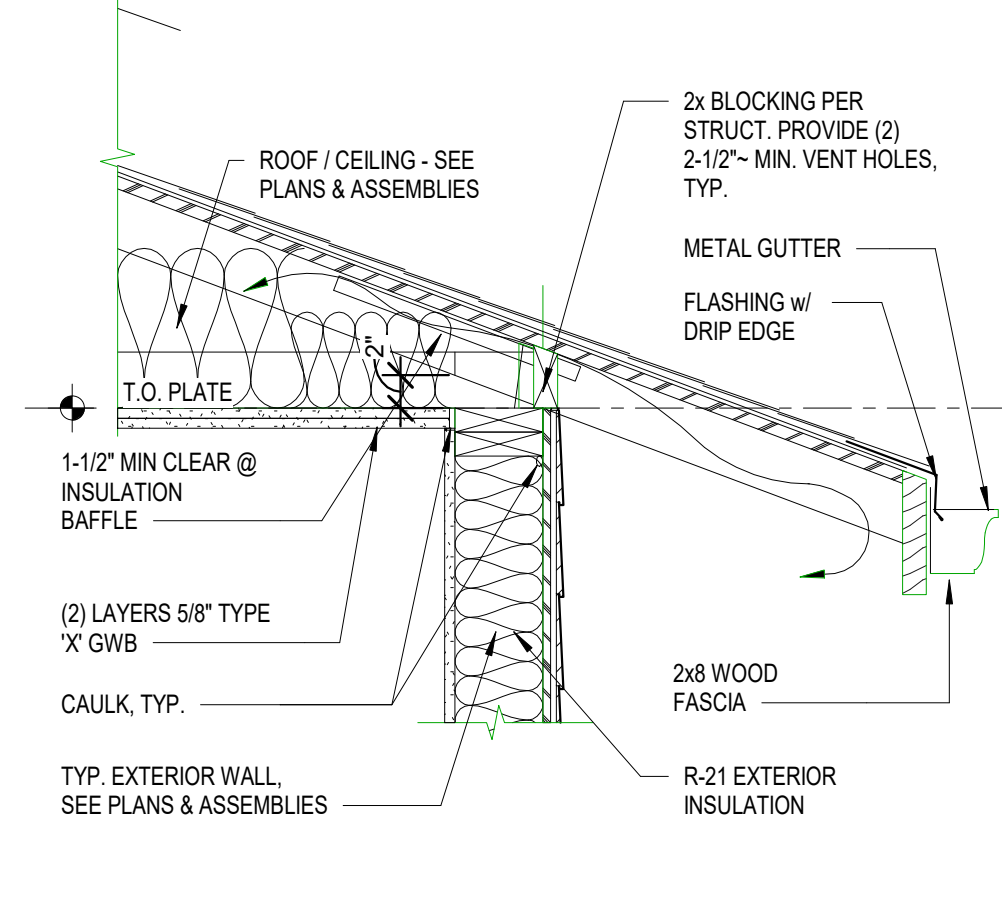

10 TYP ROOF @ EAVE DETAIL  
1" = 1'-0"

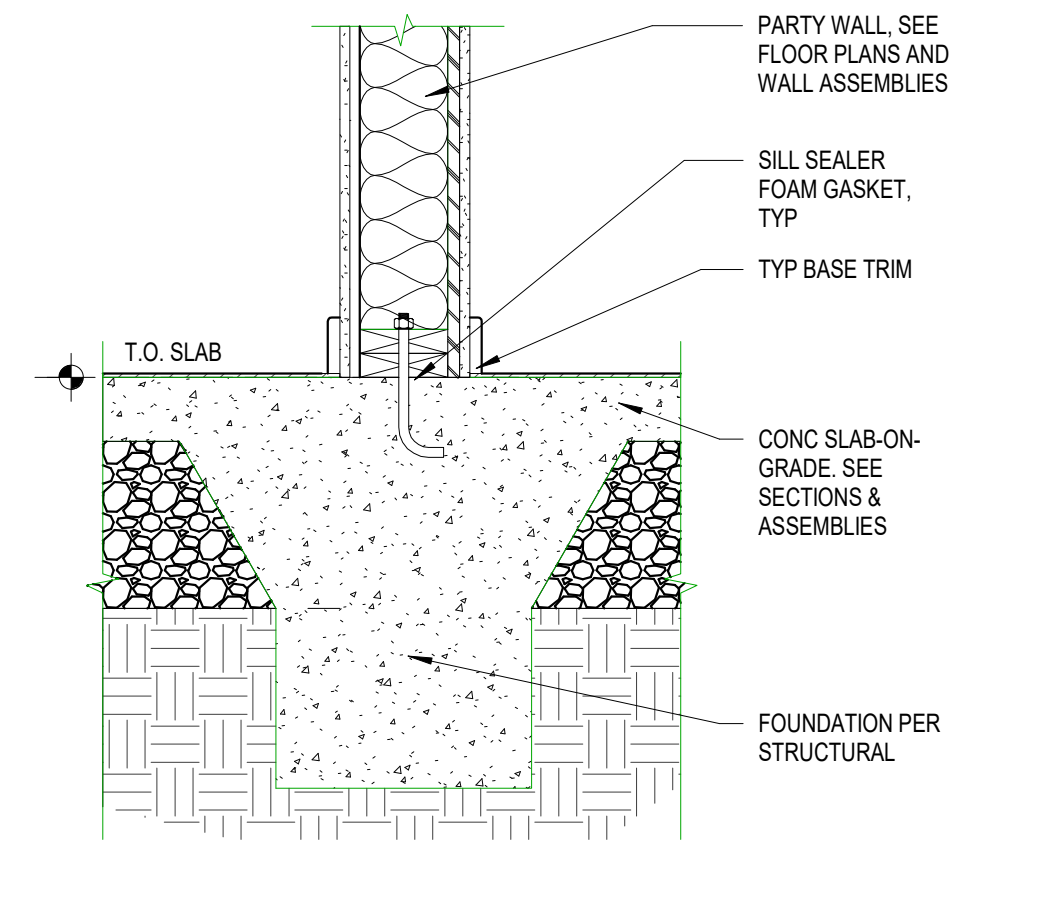

6 PARTY WALL AT SLAB ON GRADE  
1" = 1'-0"

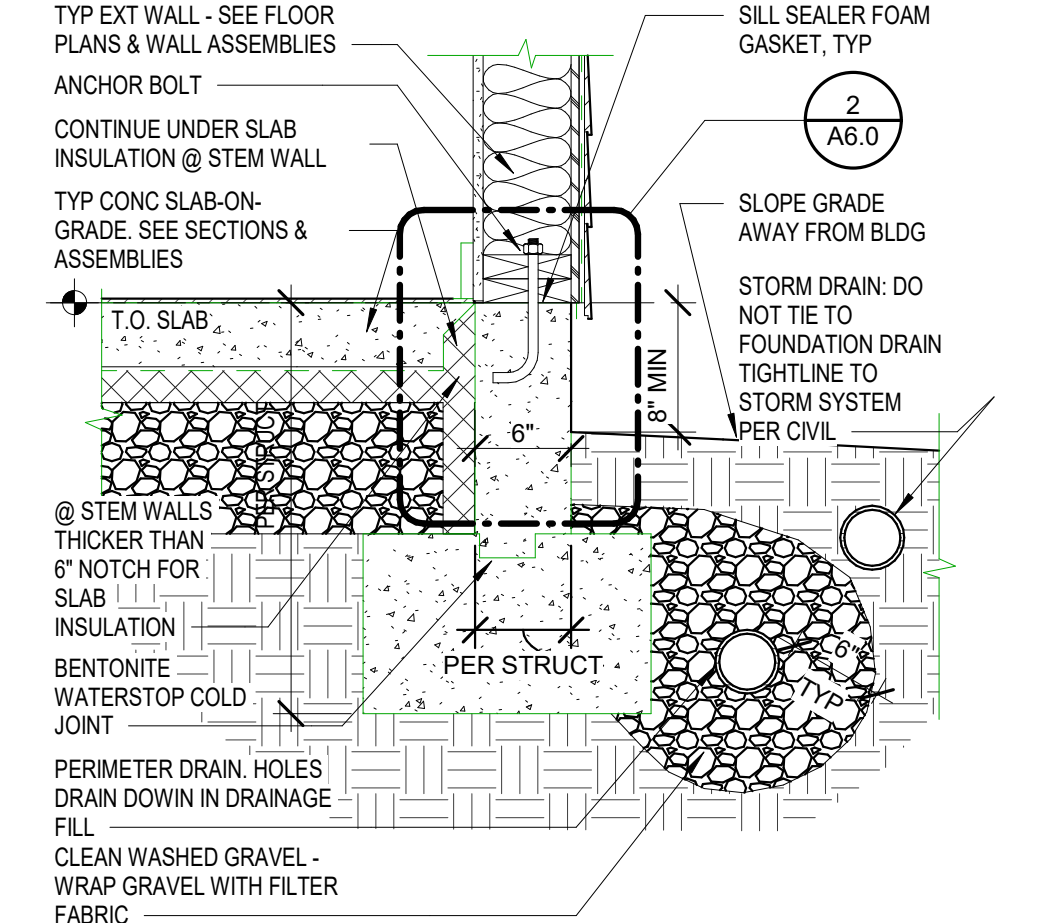

1 TYP FOOTING @ EXTERIOR WALL  
1" = 1'-0"

BRISTOL APARTMENTS  
9615 Bristol Ave SW, Lakewood, WA

DETAILS

A6.0



| REVISIONS |        |      |
|-----------|--------|------|
| #         | ISSUED | DATE |
|           |        |      |

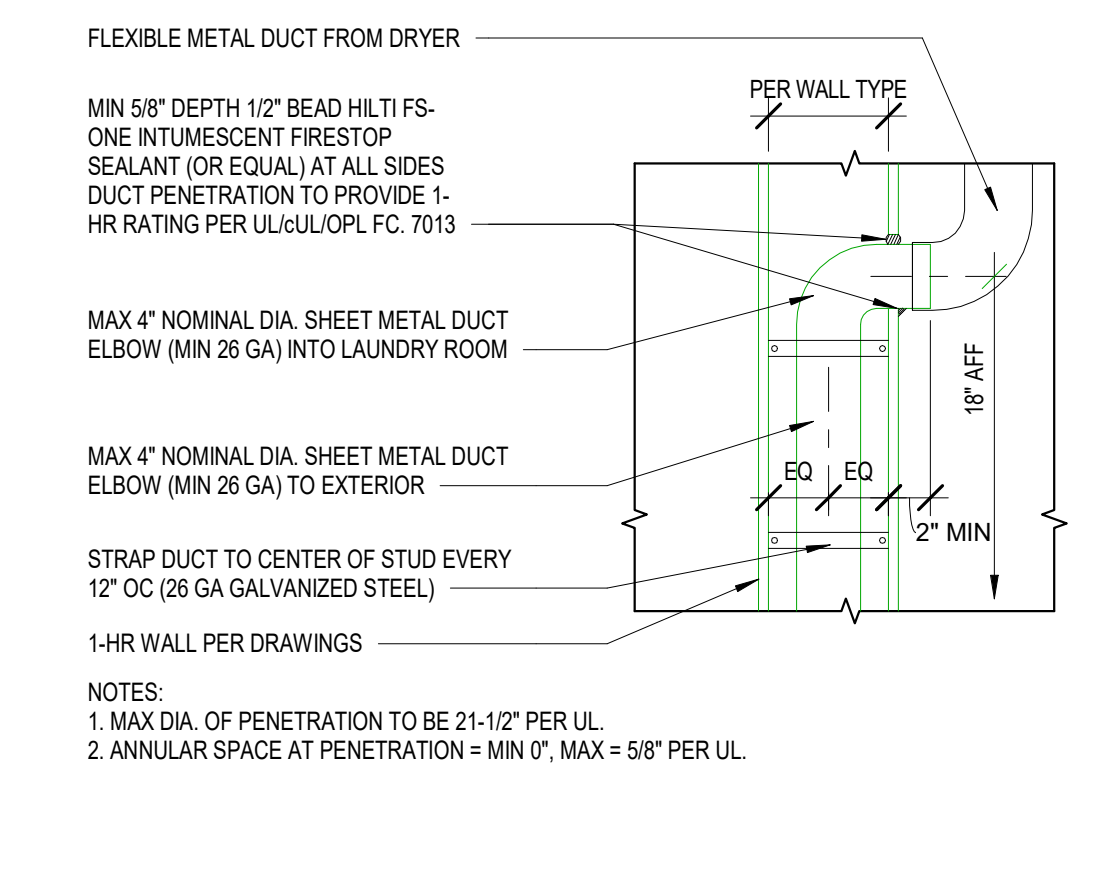
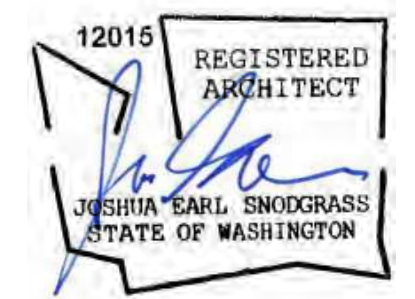

12 TYP FIRESTOPPING AT DUCT PENETRATION OF 1-HR WALL ASSY  
1" = 1'-0"

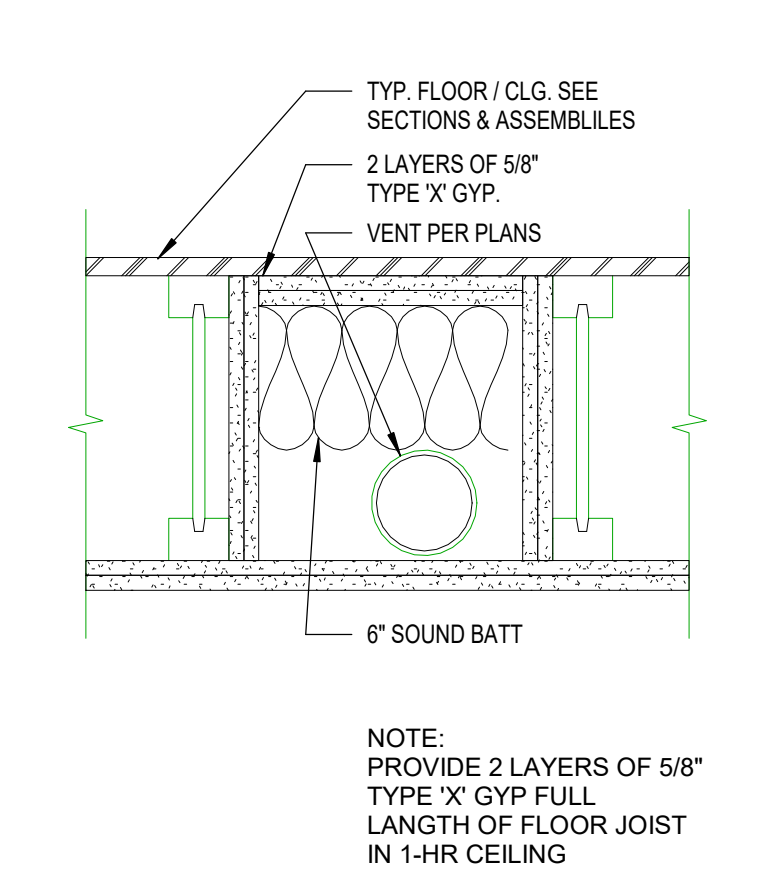

8 VENT CHASE IN FLOOR  
1 1/2" = 1'-0"

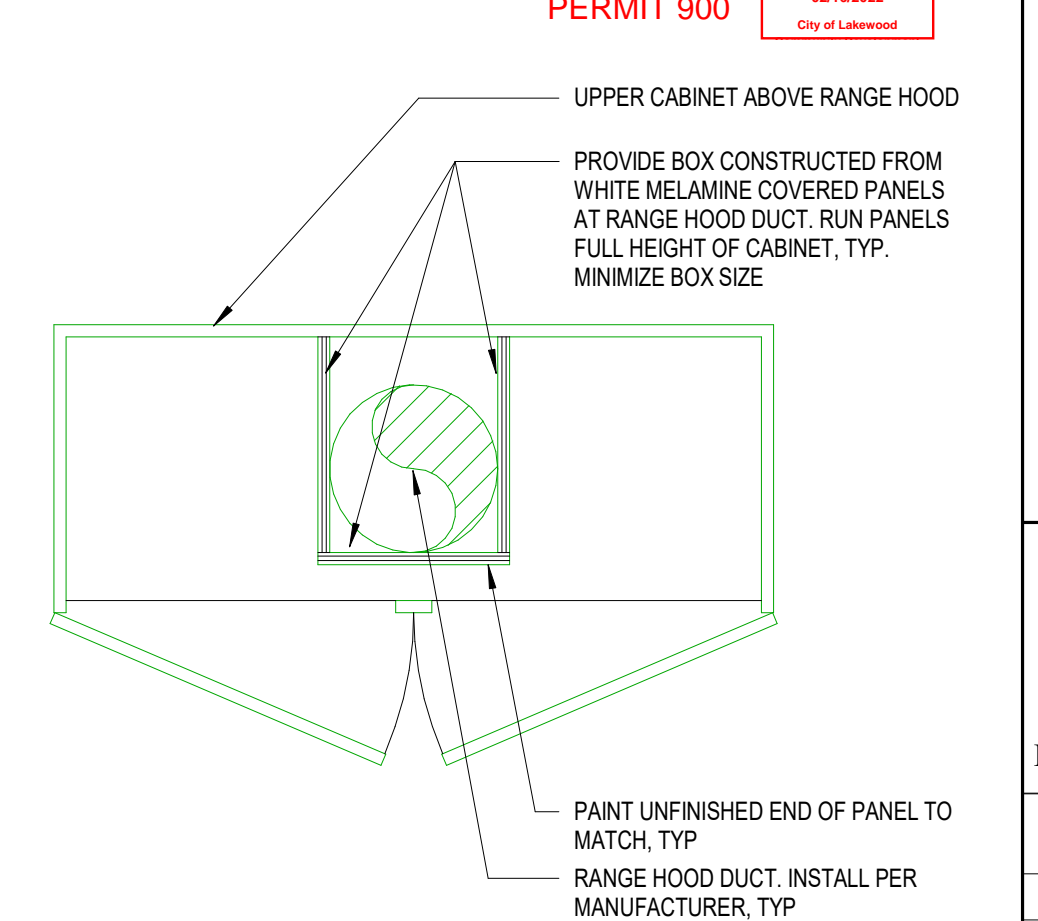

3 TYP BOXED OUT RANGE HOOD DUCT  
1 1/2" = 1'-0"

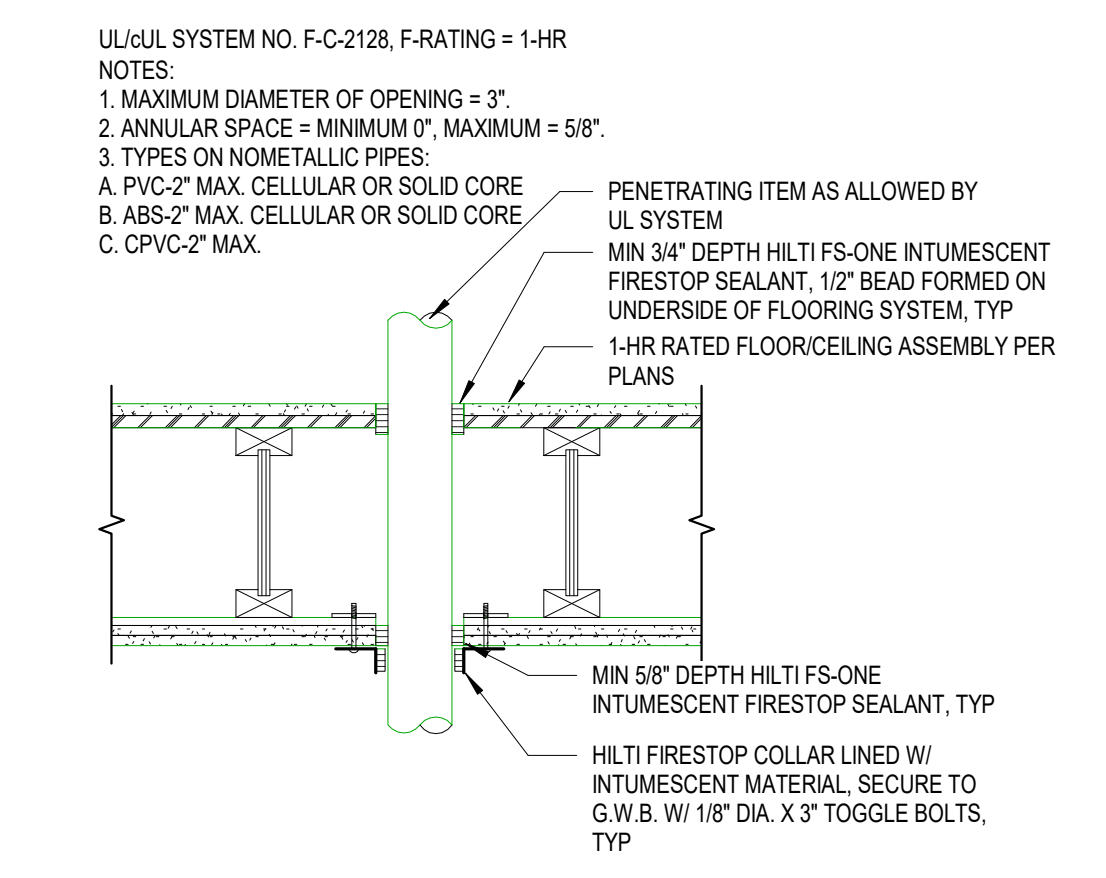

11 TYP FIRESTOPPING FOR PVC/ABS/CPVC PIPE THRU 1-HR FLR/CLG ASSY  
1" = 1'-0"

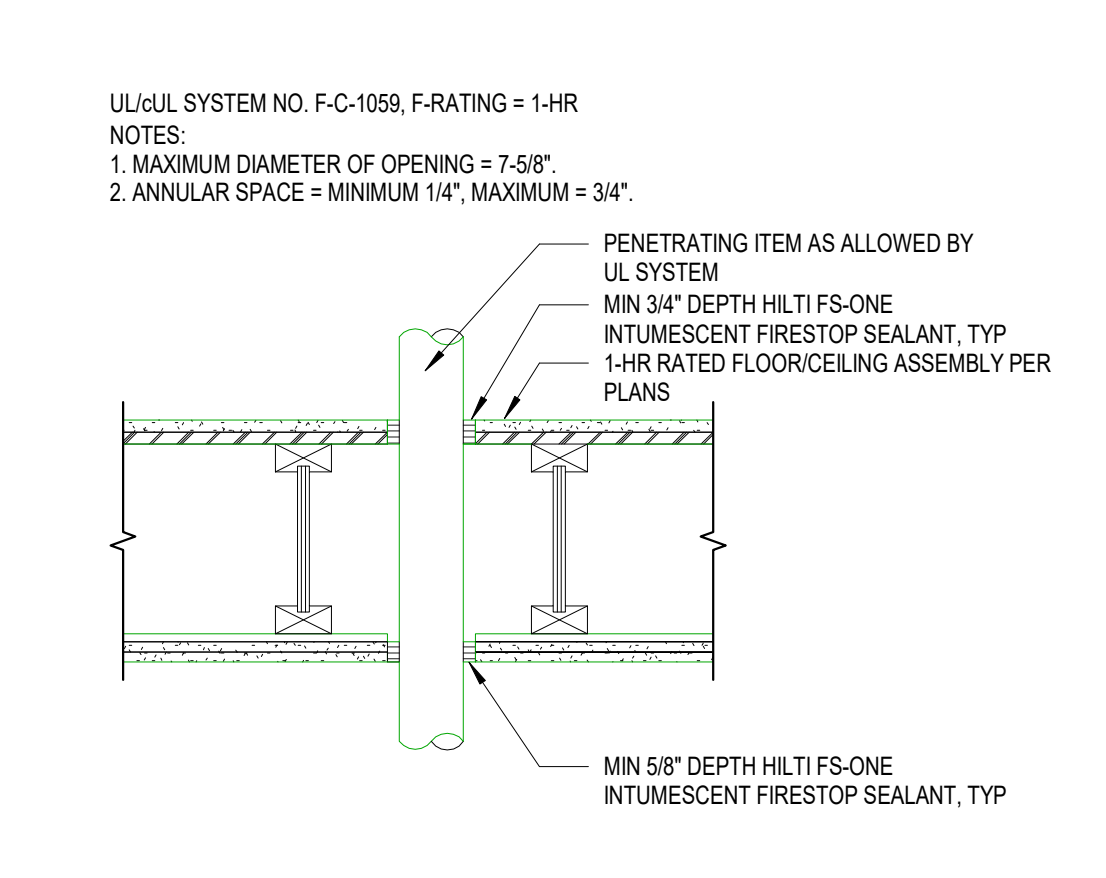

7 TYP FIRESTOPPING FOR METAL PIPE THRU 1-HR FLR/CLG ASSY  
1" = 1'-0"

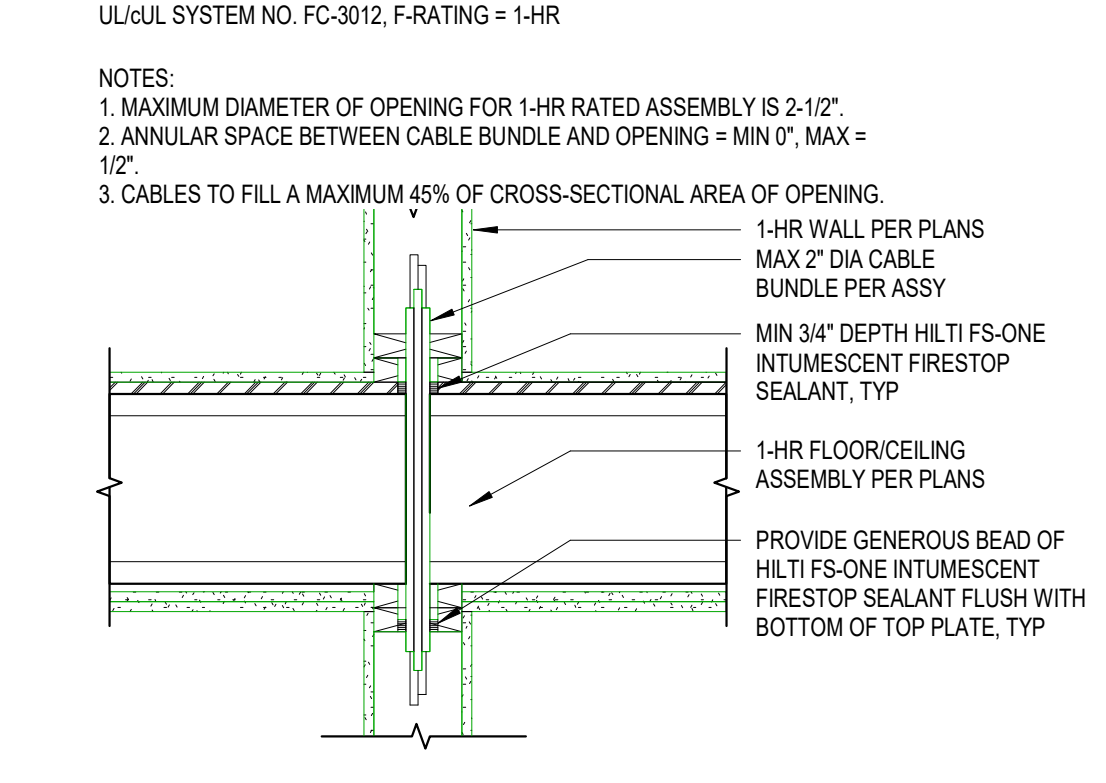

10 TYP FIRESTOPPING FOR CABLES THRU 1-HR FLR/CLG ASSY  
1" = 1'-0"

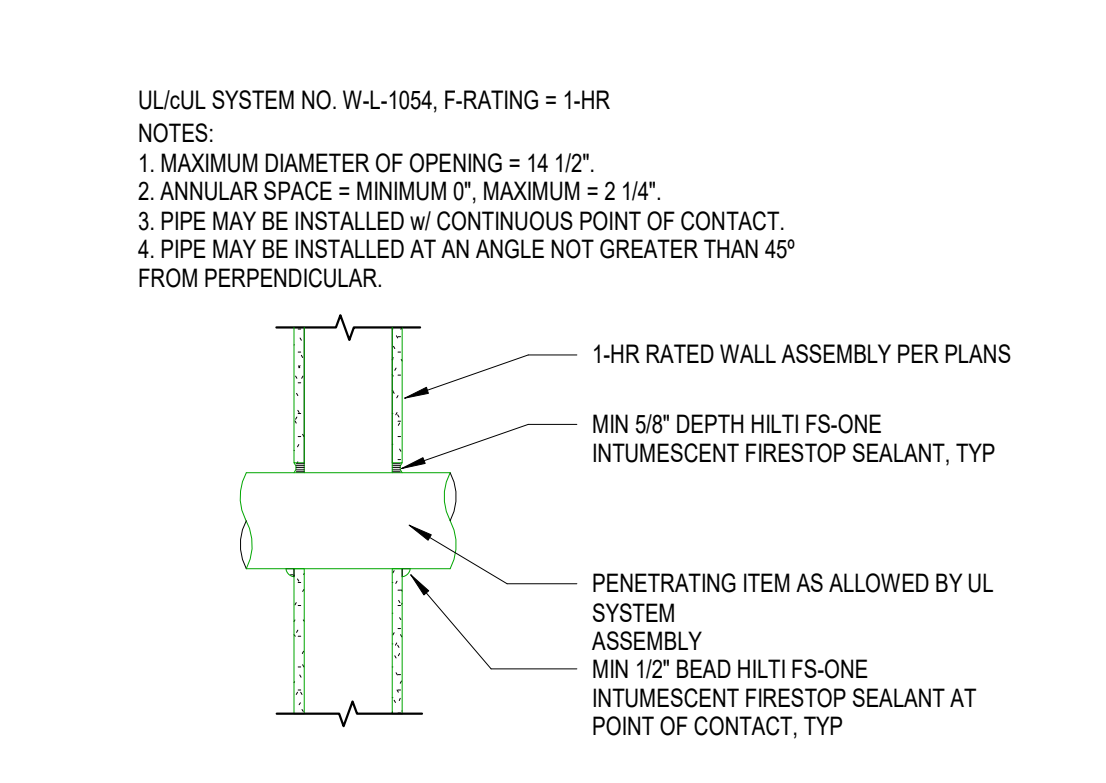

6 TYP FIRESTOPPING FOR METAL PIPE THRU 1-HR WALL ASSY  
1" = 1'-0"

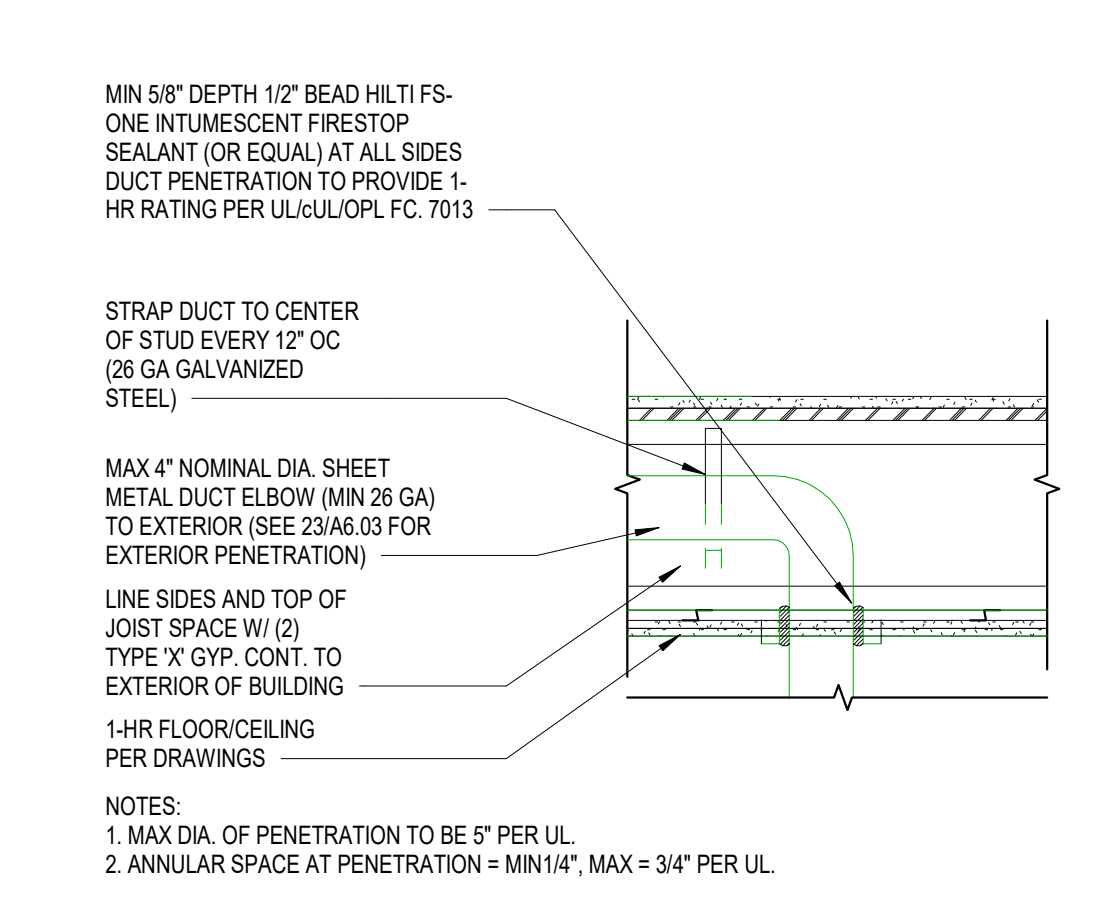

1 TYP FIRESTOPPING AT DUCT PENETRATION OF 1-HR CLG ASSY  
1" = 1'-0"

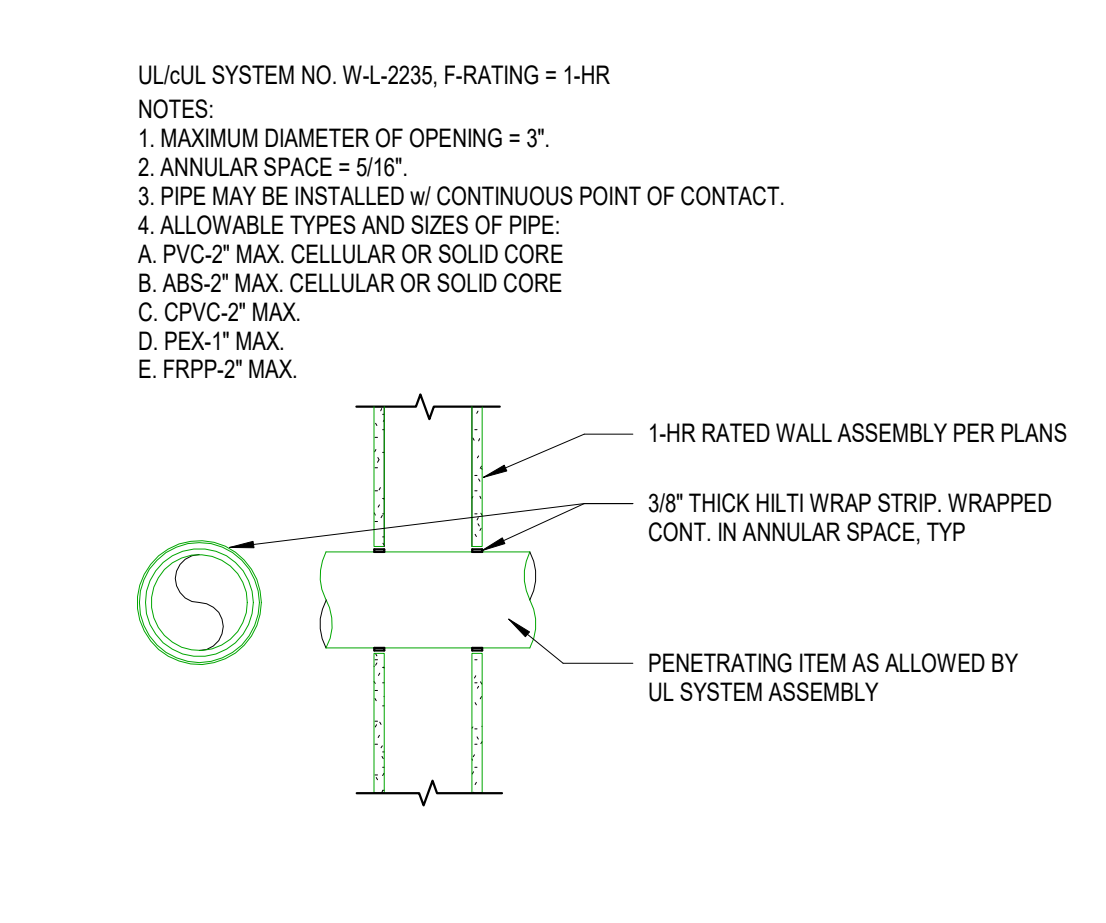

5 TYP FIRESTOPPING FOR PVC/ABS/CPVC/PEX/FRPP PIPE THRU 1-HR WALL ASSY  
1" = 1'-0"



**WINDOW NOTES:**

1. PROVIDE AT LEAST ONE WINDOW WITH A VENT PORT IN EVERY ROOM WITH WINDOWS. VENT PORTS SHALL BE CONTROLABLE AND SECURE. VENT PORT CONTROLS SHALL BE LOCATED ON THE SIDES OF WINDOWS AT HEIGHT MEETING UFAS ACCESSIBILITY STANDARDS.
2. PROVIDE LOW E ARGON DOUBLE PANED GLASS IN ALL WINDOWS.
3. ALL DIMENSIONS ARE TO THE CENTERLINE OF WINDOWS U. N. O.
4. WINDOWS SHALL HAVE A STANDARD SILL HEIGHT OF 2'-6" AND A HEAD HEIGHT OF 6'-8" U. N. O.

6. ALL WINDOWS WITHIN 24" OF DOORS, 18" OF FINISHED FLOOR, OR WITHIN 60" VERTICAL INCHES OF A STAIR TREAD SHALL HAVE TEMPERED GLASS.
7. AIR LEAKAGE AT WINDOWS SHALL NOT EXCEED 0.2 CFM/SF TESTED AT A PRESSURE OF AT LEAST 1.57 PSF IN ACCORDANCE WITH NFRC 400.
8. ALL OPERABLE WINDOWS SHALL RECEIVE SCREENS AT OPERABLE PORTIONS.
9. ANSI 117.1: SEC.309.3 WINDOW HARDWARE OPERABLE HEIGHT - PLACED WITH IN ONE OR MORE OF THE REACH RANGES SPECIFIED IN SEC.308
10. WINDOW U-FACTOR OF .28 OR BETTER
11. TYPICAL, ALL WINDOW HEADERS THAT USE A 4X FRAMING REQUIRED TO HAVE HEADER INSULATION

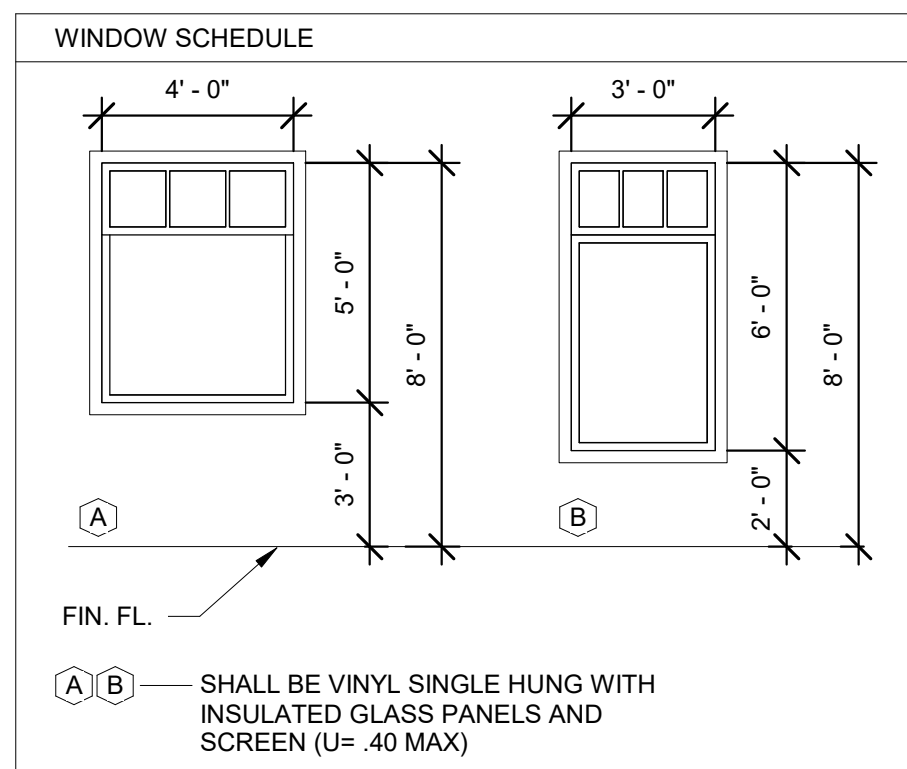

**DOOR NOTES:**

1. MAXIMUM THRESHOLD TO BE 1/2" AFF (TYP).
2. SEE SHEET A7.11 FOR DOOR TRIM DETAILS.
3. ALL UNIT ENTRY DOORS SHALL BE PROVIDED WITH A DEADBOLT OR DEAD-LOCKING LATCH BOLT WITH 1/2" MIN THROW WHICH PENETRATES THE STRIKER 1/4" MIN.
4. EXTERIOR DOORS WITHOUT FENESTRATION SHALL HAVE A MAXIMUM U VALUE OF 0.2.
5. DOOR LITES SHALL HAVE A MAXIMUM U VALUE OF 0.3 AND A MAXIMUM SOLAR HEAT GAIN COEFFICIENT OF 0.4.
6. GLAZING IN FIRE RATED DOORS SHALL BE RATED FOR FIRE RESISTANCE.
8. AIR LEAKAGE AT EXTERIOR DOORS SHALL NOT EXCEED 1.0 CFM/SF TESTED AT A PRESSURE OF AT LEAST 1.57 PSF IN ACCORDANCE WITH NFRC 400.
9. FIELD FABRICATED DOOR FRAMES SHALL COMPLY WITH SECTION 1314.1 OF THE 2009 WASHINGTON STATE ENERGY CODE.
10. REFER TO SPECIFICATIONS FOR HARDWARE GROUP DETAILS.
11. ALL GLAZING IN DOOR SHALL BE SAFTY GLAZING
12. PROVIDE LOUVERED DOORS ON WASHER AND DRYER CLOSETS

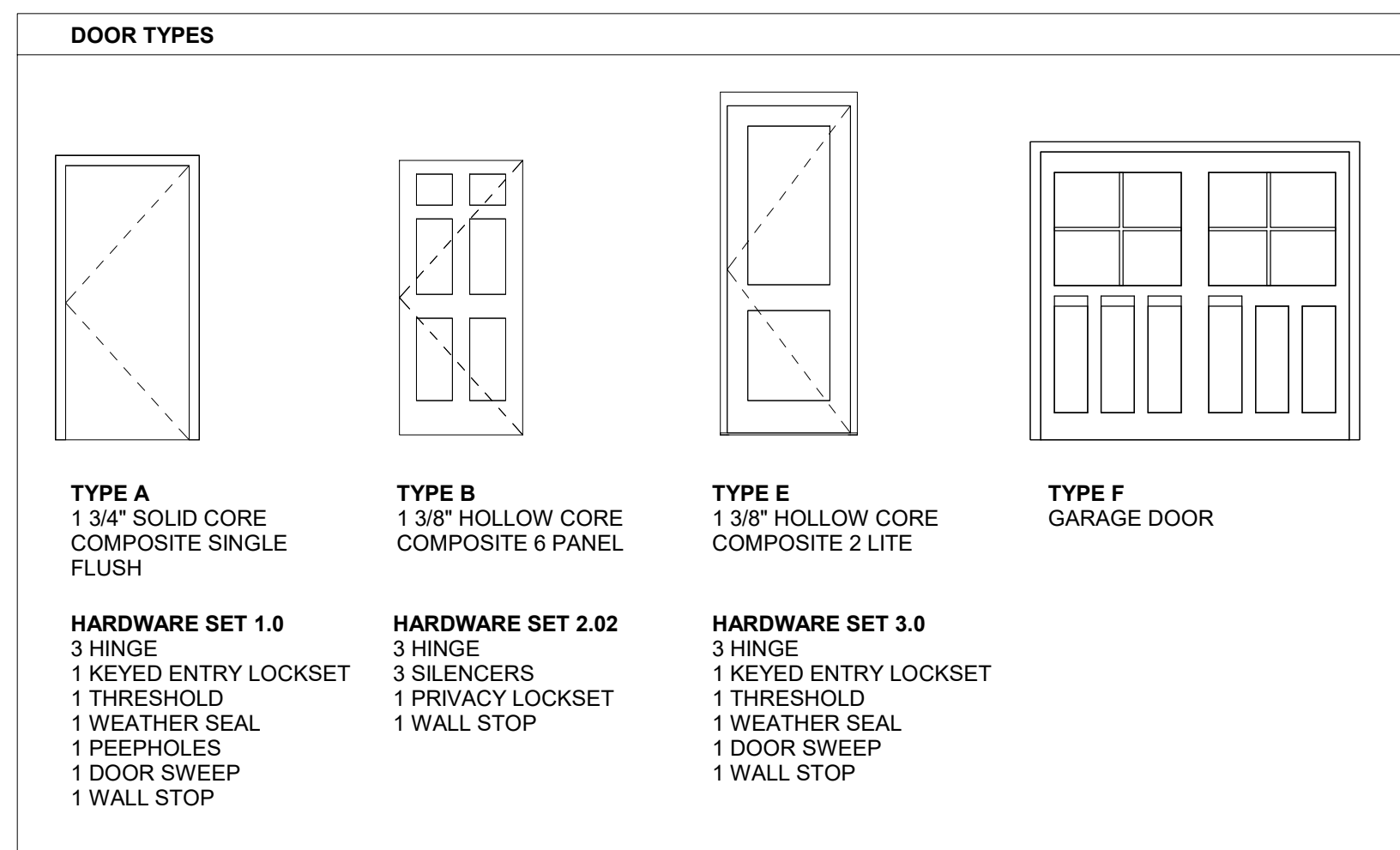

DOOR SCHEDULE COMMON DOORS

| NO.  | TYPE | DOOR MAT'L | DOOR FINISH | Width   | Height  | Thickness   | FRAME TYPE | FRAME FINISH | HARDWARE | REMARKS         |
|------|------|------------|-------------|---------|---------|-------------|------------|--------------|----------|-----------------|
| 101A | E    | WD         | PAINT       | 3' - 0" | 8' - 0" | 0' - 1 3/4" |            | PAINT        |          |                 |
| 101B | B    | WD         | PAINT       | 2' - 6" | 6' - 8" | 0' - 1 3/4" |            | PAINT        |          |                 |
| 103  | A    | WD         | PAINT       | 3' - 0" | 6' - 8" | 0' - 1 3/4" | METAL      | PAINT        |          | 20 MINUTE RATED |
| 105  | F    | WD         | PAINT       | 7' - 6" | 7' - 0" | 0' - 1 3/4" |            | PAINT        |          |                 |
| 106  | F    | WD         | PAINT       | 7' - 6" | 7' - 0" | 0' - 1 3/4" |            | PAINT        |          |                 |
| 107  | F    | WD         | PAINT       | 7' - 6" | 7' - 0" | 0' - 1 3/4" |            | PAINT        |          |                 |
| 108  | F    | WD         | PAINT       | 7' - 6" | 7' - 0" | 0' - 1 3/4" |            | PAINT        |          |                 |
| 204  | B    | WD         | PAINT       | 2' - 6" | 6' - 8" | 0' - 1 3/4" |            | PAINT        |          |                 |
| 304  | B    | WD         | PAINT       | 2' - 6" | 6' - 8" | 0' - 1 3/4" |            | PAINT        |          |                 |
| 305  | B    | WD         | PAINT       | 2' - 6" | 6' - 8" | 0' - 1 3/4" |            | PAINT        |          |                 |
| 306  | A    | WD         | PAINT       | 3' - 0" | 6' - 8" | 0' - 1 3/4" | METAL      | PAINT        |          |                 |

Window Schedule

| Type Mark | Count | Level     | Description                    | Width   | Height  | U-VAULUE |
|-----------|-------|-----------|--------------------------------|---------|---------|----------|
| A         | 3     | 1ST FLOOR | PROVIDE EGRESS IN ALL BEDROOMS | 4' - 0" | 5' - 0" | U - 0.28 |
| A         | 14    | 2ND FLOOR | PROVIDE EGRESS IN ALL BEDROOMS | 4' - 0" | 5' - 0" | U - 0.28 |
| A         | 14    | 3RD FLOOR | PROVIDE EGRESS IN ALL BEDROOMS | 4' - 0" | 5' - 0" | U - 0.28 |
| B         | 4     | 1ST FLOOR |                                | 3' - 0" | 6' - 0" | U - 0.28 |
| G         | 1     | 3RD FLOOR |                                | 2' - 6" | 5' - 0" | U - 0.28 |
| H         | 1     | 3RD FLOOR |                                | 3' - 0" | 5' - 0" | U - 0.28 |
| I         | 2     | 2ND FLOOR |                                | 2' - 6" | 5' - 0" | U - 0.28 |
| J         | 1     | 2ND FLOOR |                                | 4' - 0" | 4' - 0" | U - 0.28 |

PROJ ID 643  
PERMIT 900

RECEIVED  
10/10/2022  
City of Lakewood



LJB DESIGNS, LLC  
111 Market Street N.E., Suite 325  
Olympia, Washington 98501  
(360) 867-1945  
E-mail: LJBDesigns@Comcast.net

REVISIONS

| # | ISSUED | DATE    |
|---|--------|---------|
| 1 |        | 4/27/20 |

12015 REGISTERED ARCHITECT  
JOSHUA EARL SMOGRASS  
STATE OF WASHINGTON

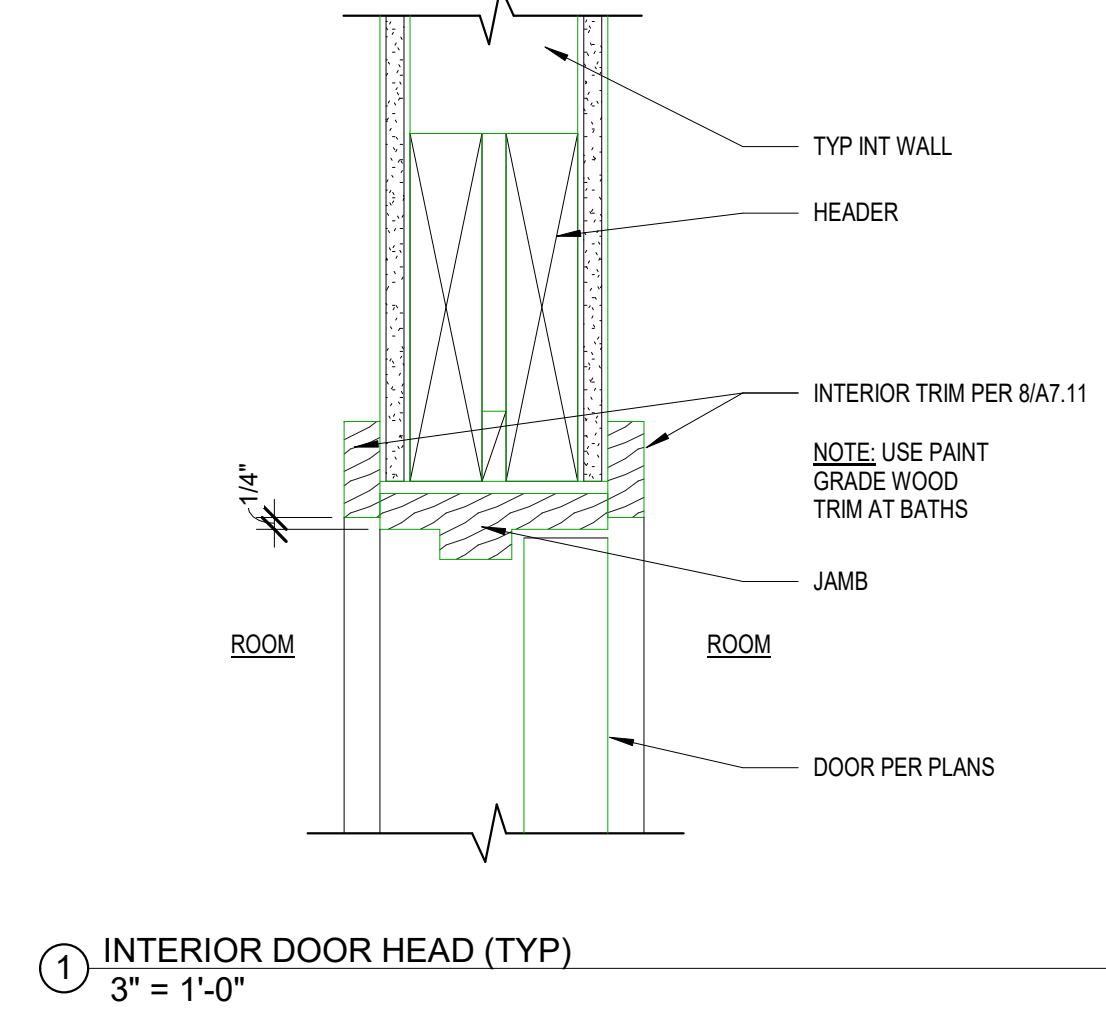
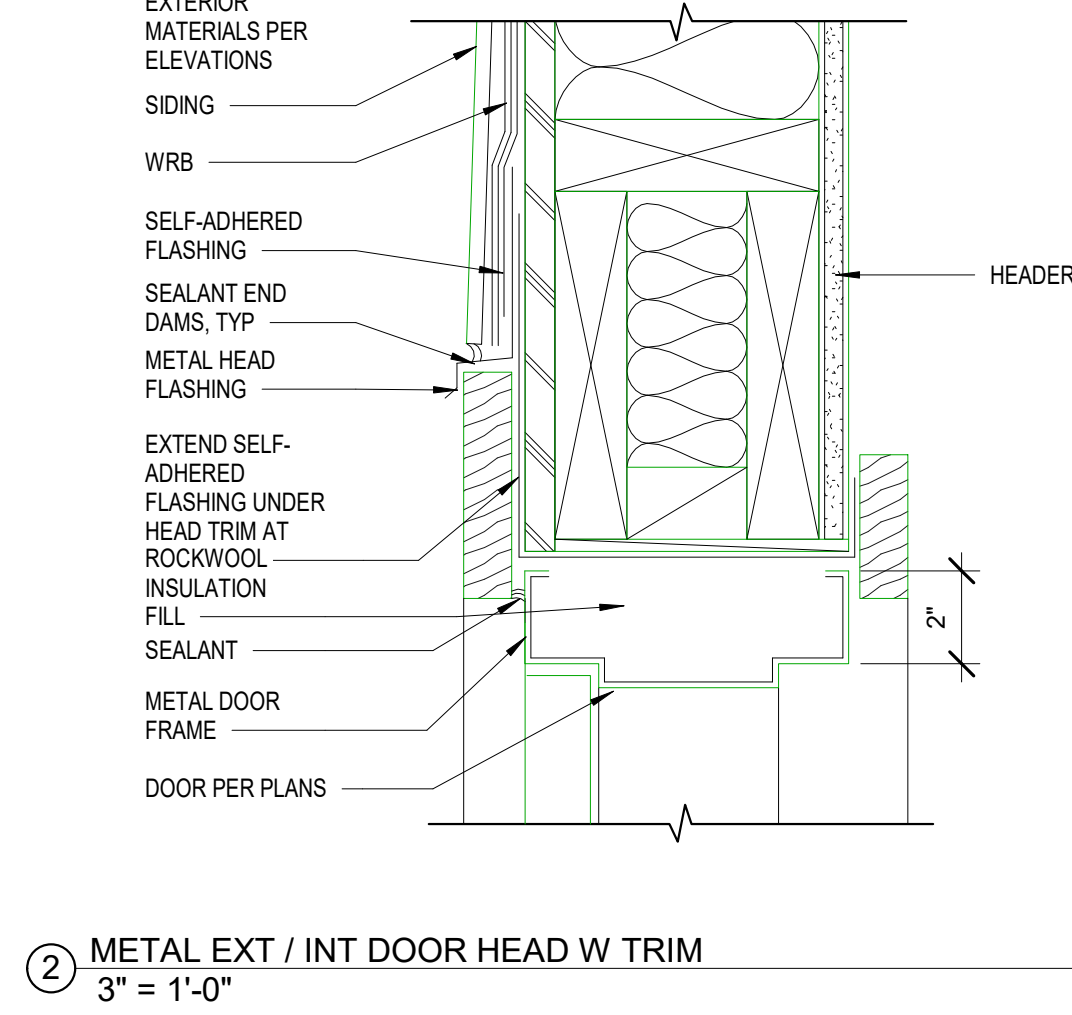
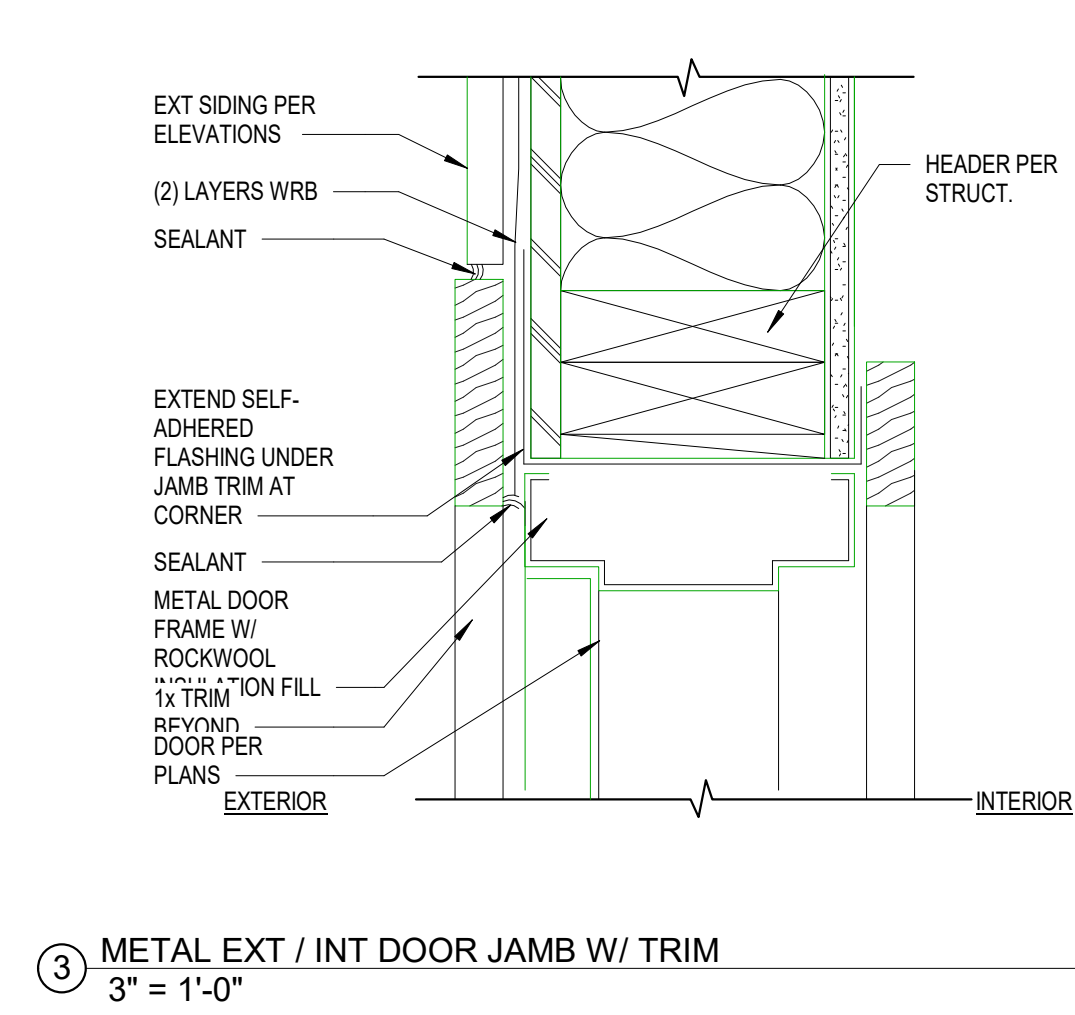
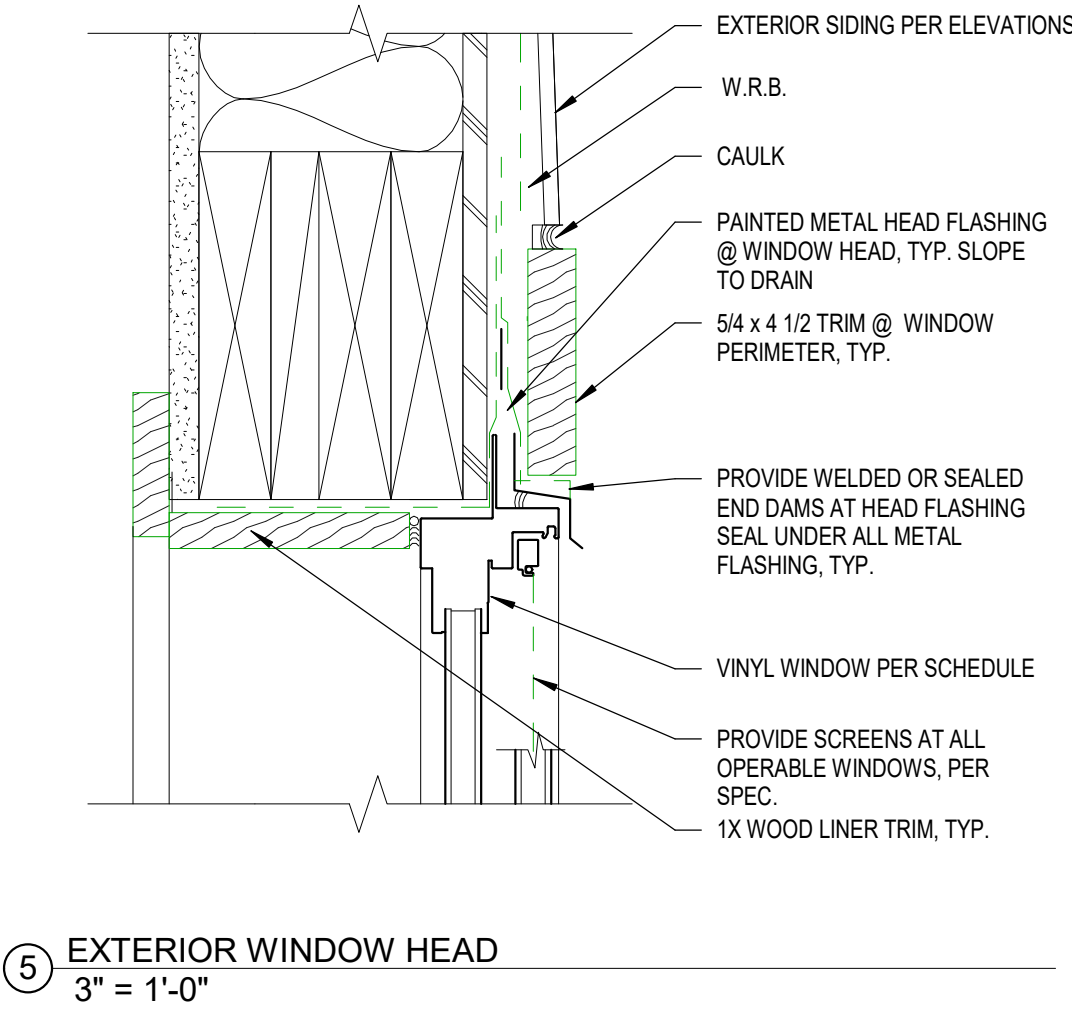
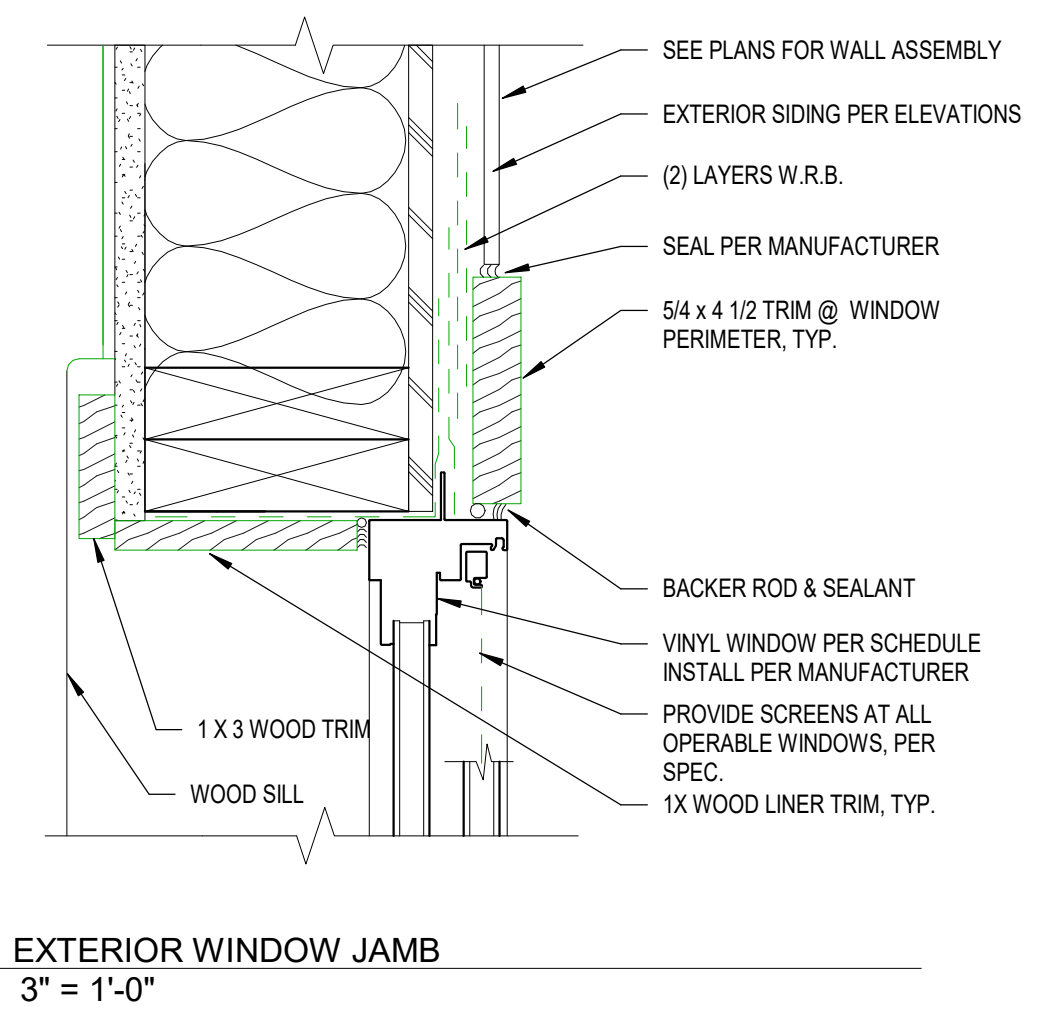
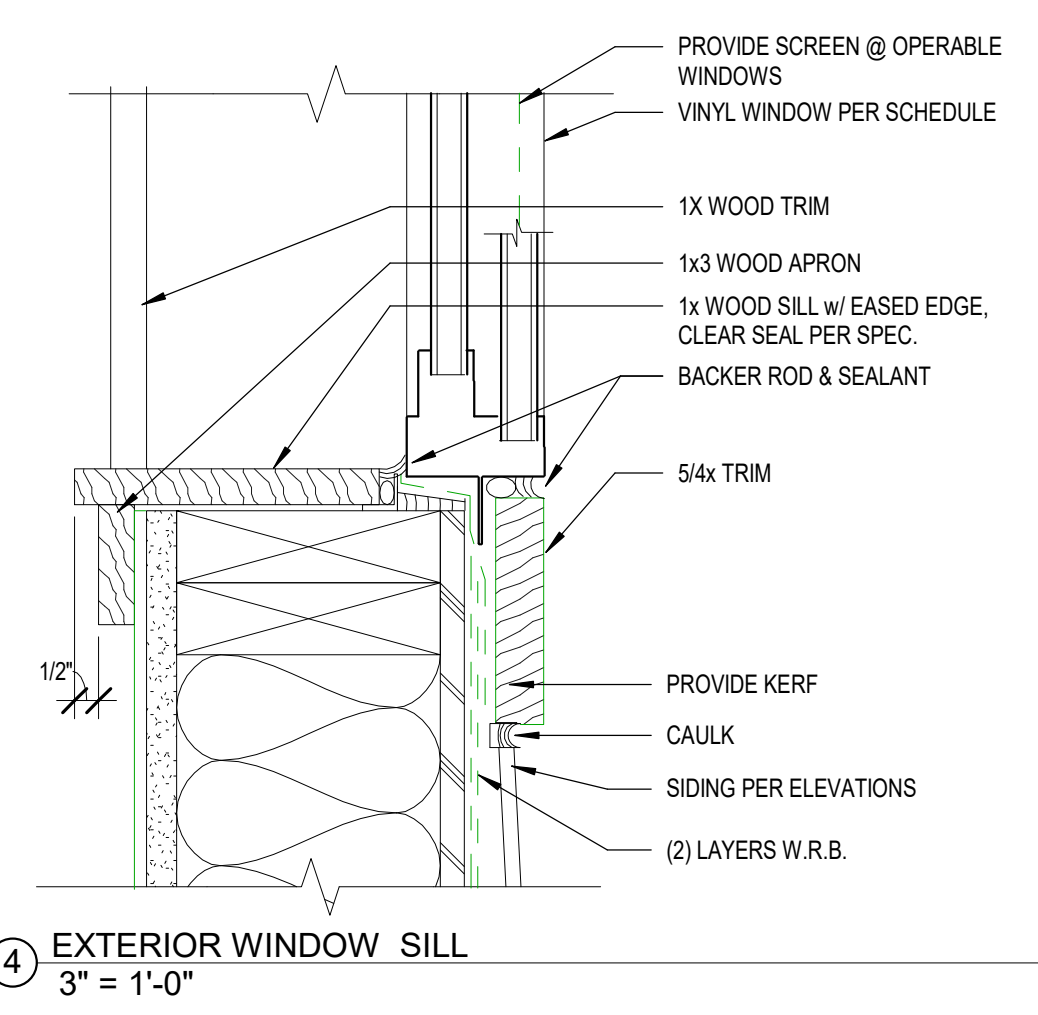

BRISTOL APARTMENTS  
9615 Bristol Ave SW, Lakewood, WA

DOOR/WINDOW SCHEDULE, DETAILS

RESOLUTION NO. 2022-XX

A RESOLUTION of the City Council of the City of Lakewood, Washington, authorizing the issuance of Conditional Certificate of Acceptance of Tax Exemption within a Residential Target Area to Kurkov Konstantin.

WHEREAS, pursuant to chapter 84.14 RCW and chapter 3.64 of the Lakewood Municipal Code; municipalities may identify Residential Target Areas. Such areas are designed to spur economic development and developments within those areas may be allowed certain tax benefits; and

WHEREAS, the City of Lakewood has received an application from Kurkov Konstantin proposing a project within a Residential Target Area.

WHEREAS, the project meets the requirements, relative to location, size, housing and compliance with other guidelines meriting conditional approval for tax purposes;

NOW, THEREFORE, THE CITY COUNCIL OF THE CITY OF LAKEWOOD, WASHINGTON HEREBY RESOLVES, AS FOLLOWS:

Section 1. The City Council approves the application from Kurkov Konstantin for a Conditional Certificate of Acceptance of Tax Exemption (“Conditional Certificate”).

Section 2. The City Manager or designee is authorized to issue a Conditional Certificate of Acceptance of Tax Exemption and to execute any appropriate documents relative to the issuance of the Conditional Certificate, including the agreement in the form attached hereto as Exhibit A to this Resolution and incorporated by reference. This Conditional Certificate shall expire three years from the effective date of this resolution. The City Manager or designee is authorized to extend or revoke the Conditional Certificate as permitted in chapter 3.64 of the Lakewood Municipal Code.

Section 3. Any actions taken by the City Manager or designees to-date in connection with the Conditional Certificate of Acceptance of Tax Exemption be and hereby are ratified.

Section 4. That this Resolution shall be in full force and effect upon passage and signatures hereon.

PASSED by the City Council this 5th day of December 2022.

CITY OF LAKEWOOD

\_\_\_\_\_  
Jason Whalen, Mayor

Attest:

\_\_\_\_\_  
Briana Schumacher, City Clerk

Approved as to Form:

\_\_\_\_\_  
Heidi Ann Wachter City Attorney

DRAFT

## CONDITIONAL CERTIFICATE OF TAX EXEMPTION

THIS CONTRACT is entered into on the date signed below between Kurkov Konstantin, hereinafter referred to as “Applicant,” and the City of Lakewood, Washington, a municipal corporation, hereinafter referred to as “City”.

This Conditional Certificate of Acceptance of Tax Exemption is being issued pursuant to Chapter 84.14 RCW, and Chapter 3.64 of the Lakewood Municipal Code, and is based on information provided by the applicant. The Conditional Certificate will be effective for not more than three (3) years from the time of issuance, and may be extended for up to twenty-four (24) additional months pursuant to LMC 3.64.020 (I). The City will issue a Final Certificate of Tax Exemption upon completion of the project, satisfactory fulfillment of all contract terms, final building inspection approval and issuance of a Certificate of Occupancy.

The Lakewood City Council authorized this limited tax exemption through Resolution No. 2022-XX, effective *Month, Day, Year*. For the purposes of vesting of rights under the application, this Conditional Certificate of Tax Exemption shall be considered to have vested under the rules applicable on *Month Day, 2022*. Pursuant to RCW 84.14.020, subject to all other applicable limitations and conditions, this tax exemption shall be of a twelve-year duration and is dependent on the inclusion of 20% percent of the multifamily housing units as affordable housing units to low- and moderate-income households.

### PROJECT DESCRIPTION

The applicant is proposing to construct a 7 unit mixed use development on approximately .14 acres located at 9615 Bristol Ave SW in the City of Lakewood, Washington Pierce County Assessor’s Parcel (APN) # 9820000020. The property is located on the east side of Bristol Ave SW off of Mount Tacoma DR SW. The proposed development use type, *mixed use*, is a primary permitted use in the applicable central business district (CBD) zoning district. The property is located in the Downtown Subarea overlay district. The applicant has agreed to construct street improvements and landscaping along Bristol Ave SW in compliance Chapter 18B of the Lakewood Municipal Code.

The project site is currently vacant. The new development will consist of 7 one-bedroom units, 4 garage spaces and 7 undesignated parking spaces. The first floor will include 329sf of commercial retail space, a single one-bedroom apartment and 4 garages. The second floor will include three one-bedroom units. The third floor will include three one-bedroom units. The total building square footage is approximately 6,040 square feet. The project is proposing to fulfill affordable housing mandates as outlined in Chapter 3.64 of the Lakewood Municipal Code and set aside 100% of all units for affordable housing.

An application for tax exemption was filed with the City of Lakewood on July 18, 2022. On *MONTH DAY, 2022*, the Lakewood City Council adopted Resolution 2022-XX authorizing the City Manager to enter into an agreement with the applicant certifying a twelve-year property tax exemption pursuant to Chapter 84.14 RCW.

In adopting Resolution 2022-XX, the Lakewood City Council determined that the project satisfied the requirements for the multi-family tax exemption including:

1. The proposed project is located within a designated Residential Target Area;
2. The proposed project meets the definition of multi-family housing pursuant to the Lakewood Municipal Code.
3. At least 50 percent of the space will be designated for multifamily housing offering permanent residential occupancy
4. The construction is proposed to be completed within 3 years of the date of approval of the application
5. The project complies with the City's comprehensive plan. Additional permits including: design review, site development and building permits will be required. At the time of application the project must comply with all applicable regulations in effect. The project has currently vested under SEPA and design review.
6. There are no existing dwelling units on-site.
7. The applicant has committed to renting at least 20% of the multifamily housing units as affordable housing units to low-and moderate-income households.

## **CONDITIONS OF TAX EXEMPTION APPROVAL**

The applicant may, upon completion of the multifamily housing and upon issuance by the City of a temporary or permanent certificate of occupancy, request a Final Certificate of Tax Exemption. The request shall be in writing directed to the City Manager and be accompanied by the following.

1. A statement of expenditures made with respect to each multi-family housing unit and the total expenditures made with respect to the entire property;
2. A description of completed work and a statement of qualification for the exemption; and
3. A statement that the work was completed within the required three-year period or any authorized extension.

In order to be issued building permits, the proposed development will require SEPA, design review and the buildings must comply with all local plans and regulations.

The City requires that building permits must be submitted for this project within 12 months of the date the conditional certificate is issued.

The parties to this agreement acknowledge and agree that at the time of completion of this project, the project shall be constructed in conformity with all local plans and regulations that applied to this project at the time the application was approved.

## **TAX EXEMPTION**

Pursuant to RCW 84.14.020, the value of the new residential construction for the project described above shall be exempt from ad valorem property taxation for a period of twelve successive years beginning January 1 of the year immediately following the calendar year of

issuance of the final certificate of tax exemption. The exemption does not include the value of land or non-housing-related improvements. This exemption does not apply to increases in assessed valuation made by the assessor on non-qualifying portions of building and value of land nor to increases made by lawful order of a county board of equalization, the department of revenue, or Pierce County to a class of property throughout the county or specific area of the county to achieve the uniformity of assessment or appraisal required by law. At the conclusion of the exemption period, the new or rehabilitated housing cost shall be considered as new construction for the purposes of chapter 84.55 RCW.

### **STATEMENT OF ADDITIONAL TAX, INTEREST, AND PENALTY DUE UPON CANCELLATION OF MULTI-FAMILY HOUSING EXEMPTION**

If the exemption is canceled for noncompliance, an additional tax shall be imposed as follows:

- a. The difference between the tax actually paid and the tax which would have been due for the pro rata portion of the tax year following cancellation, and for each tax year thereafter, if the improvements had been valued without exemption, (not to exceed 3 years before discovery of the noncompliance); plus
- b. A penalty of 20 percent of the difference, plus
- c. Interest at the statutory rate provided for delinquent property taxes is due within the times provided by RCW 84.40.350-84.40.390.

The additional tax, penalty and interest constitute a lien by the City of Lakewood upon the land which attaches at the time the property is no longer eligible for exemption, and has priority to and must be fully paid and satisfied before a recognizance, mortgage, judgment, debt, obligation, or responsibility to or with which the land may become charged or liable.

### **AFFIRMATION**

As owner(s) of the land described in this application, I hereby indicate by my signature that I am aware of the additional tax liability to which the property will be subject if the exemption authorized by Chapter 3.64 (LMC) is cancelled. I declare under penalty of perjury under the laws of the State of Washington that this application and any accompanying documents have been examined by me and that they are true, correct and complete to the best of my knowledge.

Signed at \_\_\_\_\_, Washington, this \_\_\_\_\_ day of \_\_\_\_\_, 20\_\_

Signature(s) of all Owner(s) and Contract Purchaser(s)

\_\_\_\_\_  
Kurkov Konstantin



This conditional certificate of tax exemption is hereby **approved**.

---

John Caulfield, City Manager  
City of Lakewood, Washington

Approved as to form:

---

Heidi Ann Wachter, City Attorney

DRAFT

## **AGREEMENT REGARDING RESIDENTIAL TARGET AREA CENTER DEVELOPMENT**

THIS STIPULATED AGREEMENT is entered into on the date signed below between Kurkov Konstantin hereinafter referred to as “Applicant,” and the City of Lakewood, Washington, a municipal corporation, hereinafter referred to as “City”.

### **PROJECT DESCRIPTION**

The applicant is proposing to construct a 7 unit mixed use development on approximately .14 acres located at 9615 Bristol Ave SW in the City of Lakewood, Washington Pierce County Assessor’s Parcel (APN) # 9820000020. The property is located on the east side of Bristol Ave SW off of Mount Tacoma DR SW. The proposed development use type, *mixed use*, is a primary permitted use in the applicable central business district (CBD) zoning district. The property is located in the Downtown Subarea overlay district. The applicant has agreed to construct street improvements and landscaping along Bristol Ave SW in compliance Chapter 18B of the Lakewood Municipal Code.

The project site is currently vacant. The new development will consist of 7 one-bedroom units, 4 garage spaces and 7 undesignated parking spaces. The first floor will include 329sf of commercial retail space, a single one-bedroom apartment and 4 garages. The second floor will include three one-bedroom units. The third floor will include three one-bedroom units. The total building square footage is approximately 6,040 square feet. The project is proposing to fulfill affordable housing mandates as outlined in Chapter 3.64 of the Lakewood Municipal Code and set aside 20% of all units for affordable housing.

An application for tax exemption was filed with the City of Lakewood on July 18, 2022. The application supports the following determinations:

1. The proposed project is located within a designated Residential Target Area;
2. The proposed project meets the definition of multi-family housing pursuant to the Lakewood Municipal Code.
3. At least 50 percent of the space will be designated for multifamily housing offering permanent residential occupancy
4. The construction is proposed to be completed within 3 years of the date of approval of the application
5. The project complies with the City’s comprehensive plan. Additional permits including: design review, site development and building permits will be required. At the time of application the project must comply with all applicable regulations in effect. The project has currently vested under SEPA and design review.
6. There are no existing dwelling units on-site.
7. The applicant has committed to renting at least 20% of the multifamily housing units as affordable housing units to low-and moderate-income households.

## **CONDITIONS OF TAX EXEMPTION APPROVAL**

The applicant may, upon completion of the multifamily housing and upon issuance by the City of a temporary or permanent certificate of occupancy, request a Final Certificate of Tax Exemption. The request shall be in writing directed to the City Manager and be accompanied by the following:

1. A statement of expenditures made with respect to each multi-family housing unit and the total expenditures made with respect to the entire property;
2. A description of completed work and a statement of qualification for the exemption; and
3. A statement that the work was completed within the required three-year period or any authorized extension.
4. In order to be issued building permits, the proposed development will require SEPA, design review and the buildings must comply with all local plans and regulations.
5. The City requires that building permits must be submitted for this project within 12 months of the date the conditional certificate is issued.
6. The parties to this agreement acknowledge and agree that at the time of completion of this project, the project shall be constructed in conformity with all local plans and regulations that applied to this project at the time the application was approved.

## **TAX EXEMPTION**

Pursuant to RCW 84.14.020, the value of the new residential construction for the project described above shall be exempt from ad valorem property taxation for a period of twelve successive years beginning January 1 of the year immediately following the calendar year of issuance of the final certificate of tax exemption. The exemption does not include the value of land or non-housing-related improvements. This exemption does not apply to increases in assessed valuation made by the assessor on non-qualifying portions of building and value of land nor to increases made by lawful order of a county board of equalization, the department of revenue, or Pierce County to a class of property throughout the county or specific area of the county to achieve the uniformity of assessment or appraisal required by law. At the conclusion of the exemption period, the new or rehabilitated housing cost shall be considered as new construction for the purposes of chapter 84.55 RCW.

## **STATEMENT OF ADDITIONAL TAX, INTEREST, AND PENALTY DUE UPON CANCELLATION OF MULTI-FAMILY HOUSING EXEMPTION**

If the exemption is canceled for noncompliance, an additional tax shall be imposed as follows:

- a. The difference between the tax actually paid and the tax which would have been due for the pro rata portion of the tax year following cancellation, and for each tax year thereafter, if the improvements had been valued without exemption, (not to exceed 3 years before discovery of the noncompliance); plus
- b. A penalty of 20 percent of the difference, plus

- c. Interest at the statutory rate provided for delinquent property taxes is due within the times provided by RCW 84.40.350-84.40.390.

The additional tax, penalty and interest constitute a lien by the City of Lakewood upon the land which attaches at the time the property is no longer eligible for exemption, and has priority to and must be fully paid and satisfied before a recognizance, mortgage, judgment, debt, obligation, or responsibility to or with which the land may become charged or liable.

### **AFFIRMATION**

As owner(s) of the land described in this application, I hereby indicate by my signature that I am aware of the additional tax liability to which the property will be subject if the exemption authorized by Chapter 3.64 (LMC) is cancelled. I declare under penalty of perjury under the laws of the State of Washington that this application and any accompanying documents have been examined by me and that they are true, correct and complete to the best of my knowledge.

### **AGREEMENT REQUIRES APPROVAL OF CITY COUNCIL**

In accordance with Lakewood Muni. Code 3.64.020 (H), this agreement is subject to approval by the Lakewood City Council. If this agreement is approved, the City of Lakewood shall issue a Conditional Certificate of Acceptance of Tax Administration. If this agreement is rejected by the City Council, both parties shall be discharged of their obligations under this agreement.

Signed at \_\_\_\_\_, Washington, this \_\_\_\_\_ day of \_\_\_\_\_, 20\_\_

Signature(s) of all Owner(s) and Contract Purchaser(s)

By: \_\_\_\_\_  
Kurkov Konstantin

This conditional certificate of tax exemption is hereby **approved**.

\_\_\_\_\_  
John Caulfield, City Manager  
City of Lakewood, Washington

# Bristol Apartments

LAKEWOOD CITY COUNCIL  
NOVEMBER 28, 2022



# Residential Target Area's in Lakewood

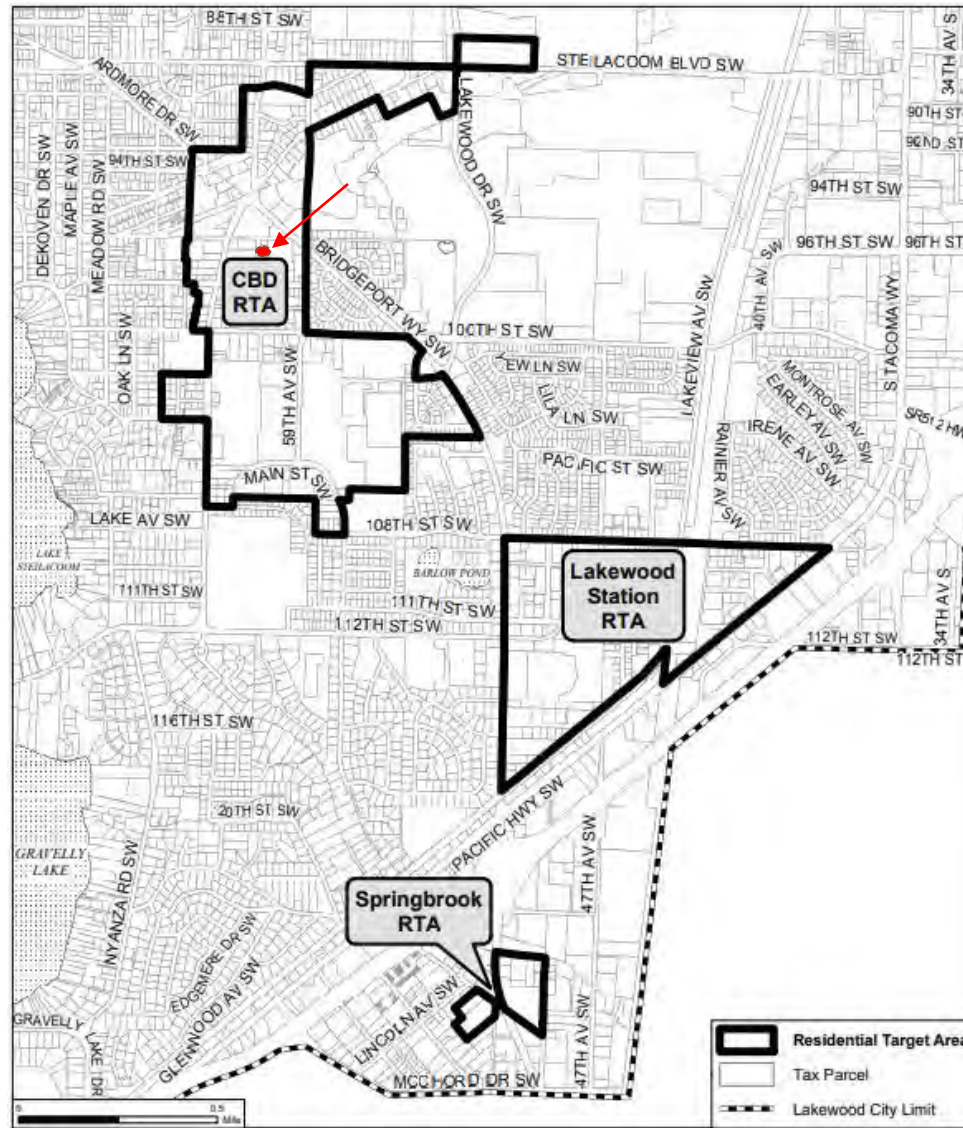



# Bristol Apartments Proposal

- 12 year exemption
- 20% of units set aside for low to moderately-low income housing
- First mixed use in Downtown
- 7, 1-bedroom units
- Office on first floor
- Garage parking
- Private balconies

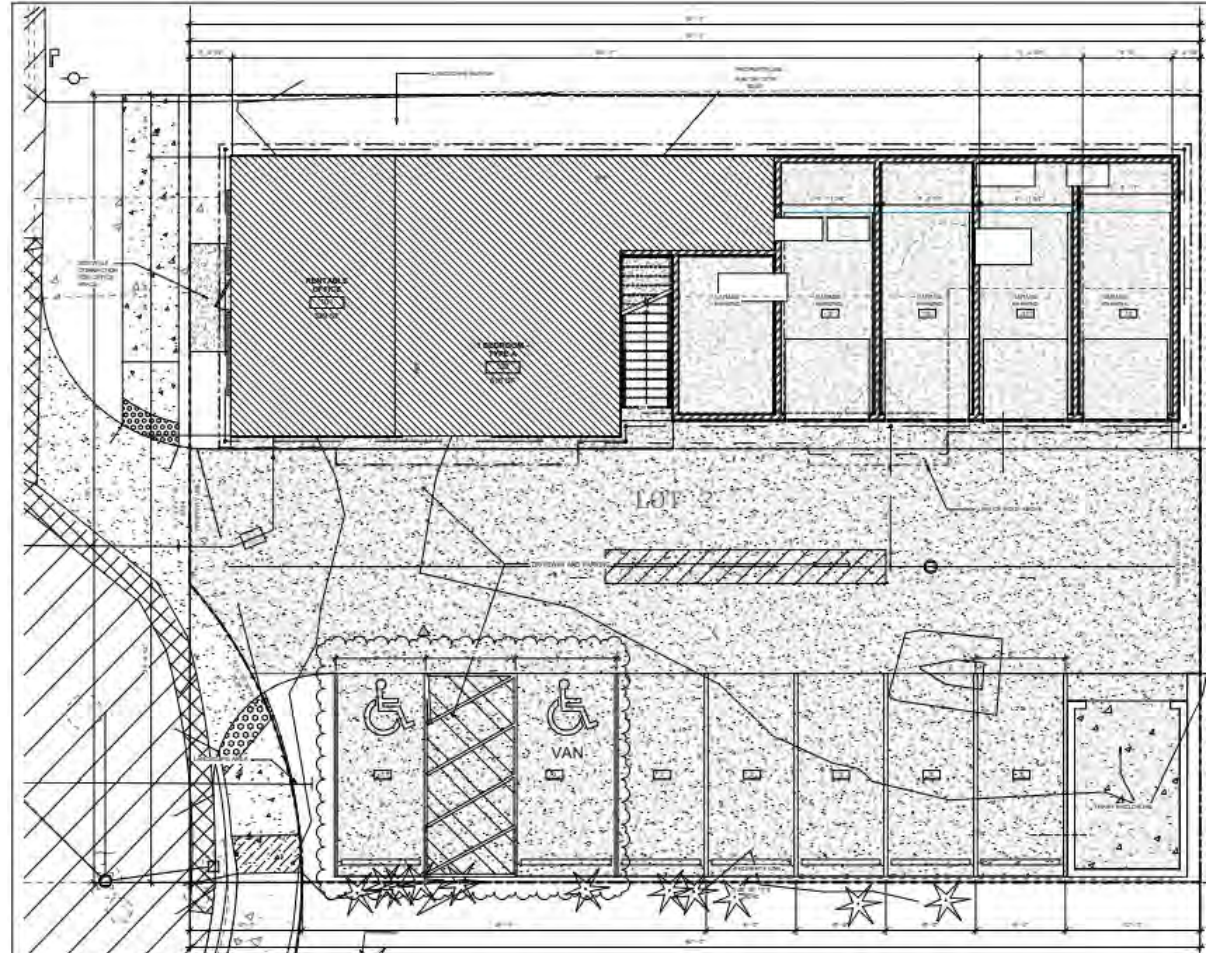

# Bristol Apartments

## First Floor

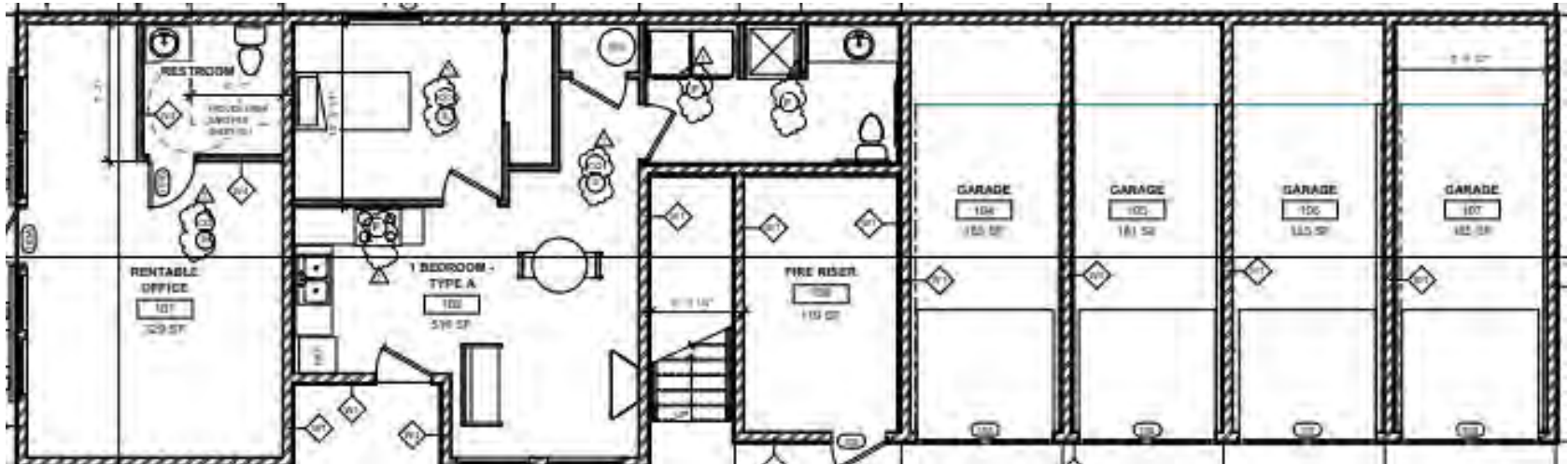

## Second and Third Floors

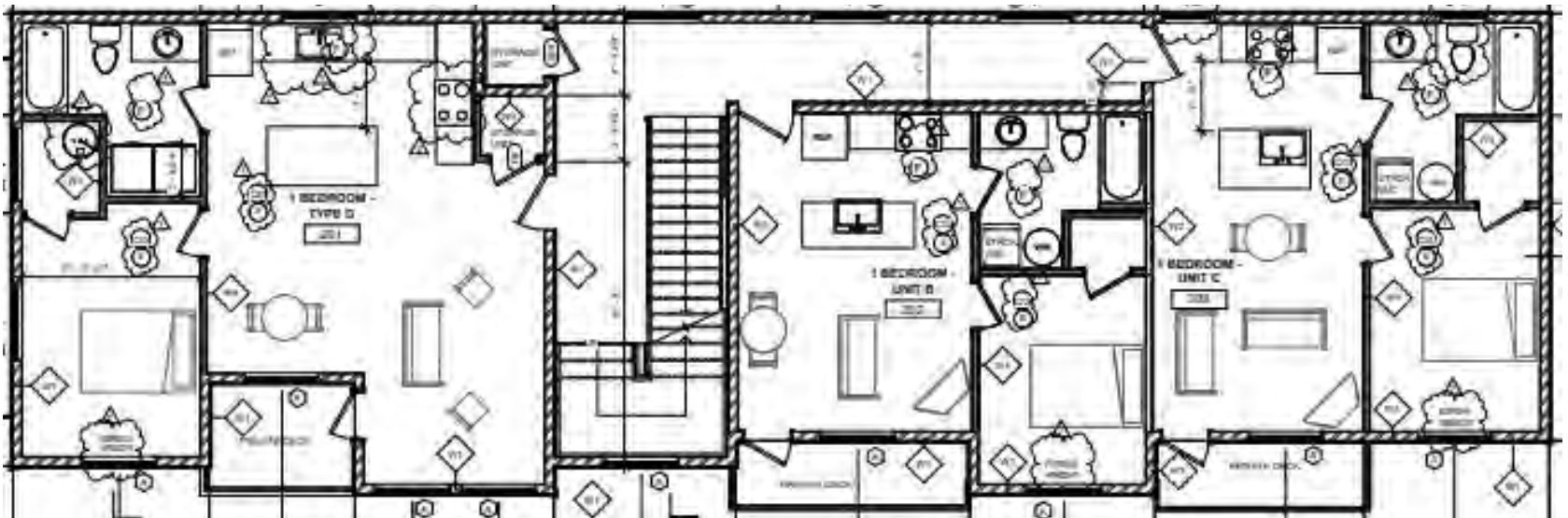



# Bristol Apartments Elevations



1 SOUTH ELEVATION  
Scale: 1/4" = 1'-0"



2 WEST ELEVATION  
Scale: 1/4" = 1'-0"

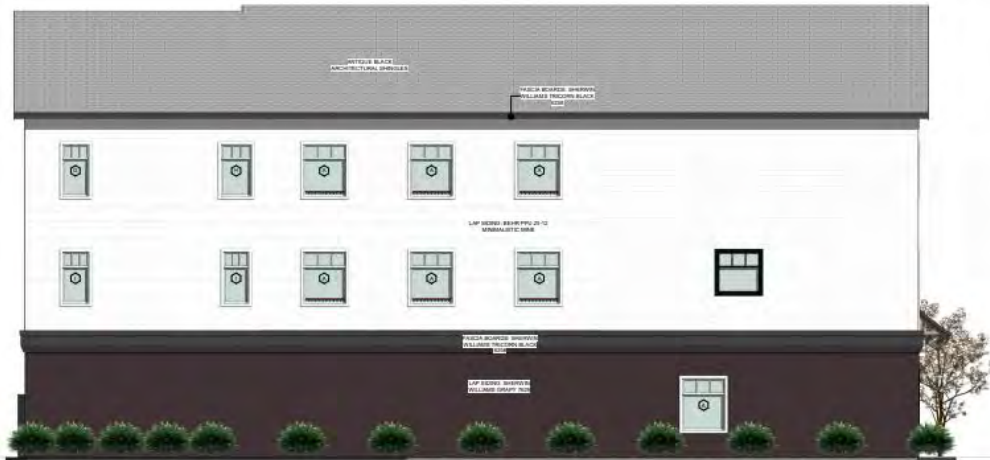

3 NORTH ELEVATION  
Scale: 1/4" = 1'-0"



4 EAST ELEVATION  
Scale: 1/4" = 1'-0"

# Bristol Apartments MFTE Program Total Property Tax



## Bristol Apartments MFTE Program 2022- 2037

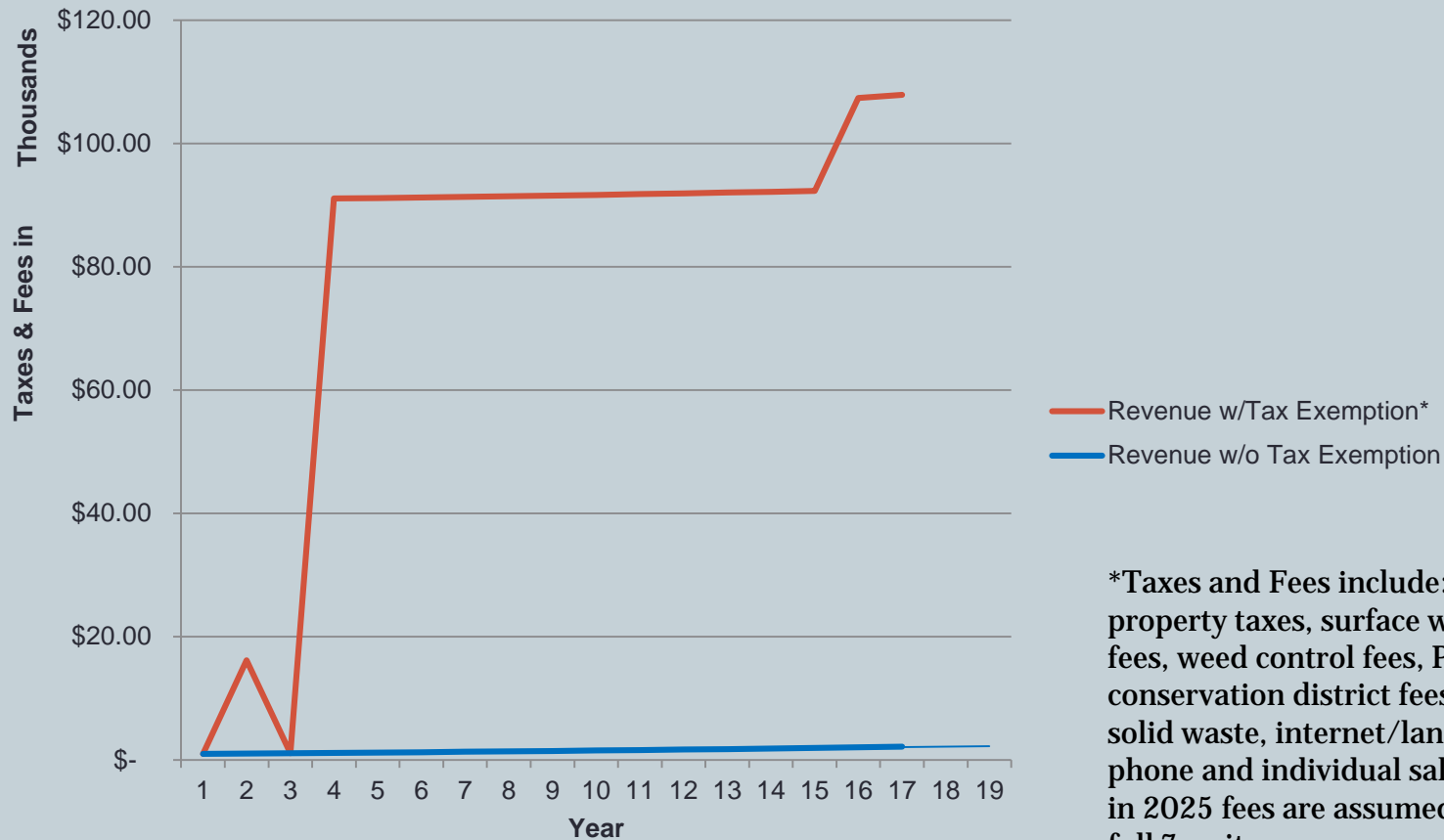

**\*Taxes and Fees include: permit fees, property taxes, surface water management fees, weed control fees, Pierce County conservation district fees, gas & electricity, solid waste, internet/landline costs, cell phone and individual sales tax. Beginning in 2025 fees are assumed to be based on full 7-unit occupancy**

# Bristol Apartments MFTE Program 2021 - 2037

## Total Property Tax



| Regional Revenue~ Proposed Bristol Apartments |                |           |                          |                           |
|---|----------------|-----------|--------------------------|---------------------------|
|   | Year           |           | Revenue w/Tax Exemption* | Revenue w/o Tax Exemption |
| Application and Project Development           | <b>1</b>       | 2021      | \$ 998.39                | \$ 998.39                 |
|   | <b>2</b>       | 2022      | \$ 16,174.20             | \$ 1,048.31               |
|   | <b>3</b>       | 2023      | \$ 1,094.82              | \$ 1,100.73               |
| Tax Exemption duration (12 years)             | <b>4</b>       | 2024      | \$ 91,085.44             | \$ 1,155.76               |
|   | <b>5</b>       | 2025      | \$ 91,172.28             | \$ 1,213.55               |
|   | <b>6</b>       | 2026      | \$ 91,263.47             | \$ 1,274.23               |
|   | <b>7</b>       | 2027      | \$ 91,359.21             | \$ 1,337.94               |
|   | <b>8</b>       | 2028      | \$ 91,459.74             | \$ 1,404.84               |
|   | <b>9</b>       | 2029      | \$ 91,565.29             | \$ 1,475.08               |
|   | <b>10</b>      | 2030      | \$ 91,676.13             | \$ 1,548.83               |
|   | <b>11</b>      | 2031      | \$ 91,792.50             | \$ 1,626.27               |
|   | <b>12</b>      | 2032      | \$ 91,914.70             | \$ 1,707.59               |
|   | <b>13</b>      | 2033      | \$ 92,043.00             | \$ 1,792.97               |
|   | <b>14</b>      | 2034      | \$ 92,177.72             | \$ 1,882.61               |
|   | Post-Exemption | <b>15</b> | 2035                     | \$ 92,319.18              |
| <b>16</b>                                     |                | 2036      | \$ 107,380.14            | \$ 2,075.58               |
| <b>17</b>                                     |                | 2037      | \$ 107,914.48            | \$ 2,179.36               |

\* Includes estimated value of local utility costs per household: gas & electricity, solid waste, internet, cellphone and estimated sales tax per person.

# Bristol Apartments MFTE Program 2021 - 2037

## Total Property Tax



| City of Lakewood Revenue ~ Proposed Bristol Apartments MFTE |      |             |                   |              |                 |
|---|------|-------------|-------------------|--------------|-----------------|
|   | Year | Vacant Land | Completed Project | Tax Exempted | Other revenue** |
| Application and Project Development                         | 1    | \$ 70.95    | \$ 70.95          | \$ -         | \$ -            |
|   | 2    | \$ 74.49    | \$ 15,222.92 *    | \$ -         | \$ -            |
|   | 3    | \$ 78.22    | \$ 78.22          | \$ -         | \$ -            |
| Tax Exemption duration (12 years)                           | 4    | \$ 82.13    | \$ 124.09         | \$ 728.33    | \$ 89,348.62    |
|   | 5    | \$ 86.24    | \$ 130.29         | \$ 746.54    | \$ 89,348.62    |
|   | 6    | \$ 90.55    | \$ 136.81         | \$ 765.20    | \$ 89,348.62    |
|   | 7    | \$ 95.08    | \$ 143.65         | \$ 784.33    | \$ 89,348.62    |
|   | 8    | \$ 99.83    | \$ 150.83         | \$ 803.94    | \$ 89,348.62    |
|   | 9    | \$ 104.82   | \$ 158.37         | \$ 824.04    | \$ 89,348.62    |
|   | 10   | \$ 110.06   | \$ 166.29         | \$ 844.64    | \$ 89,348.62    |
|   | 11   | \$ 115.57   | \$ 174.60         | \$ 865.75    | \$ 89,348.62    |
|   | 12   | \$ 121.34   | \$ 183.33         | \$ 887.40    | \$ 89,348.62    |
|   | 13   | \$ 127.41   | \$ 192.50         | \$ 909.58    | \$ 89,348.62    |
|   | 14   | \$ 133.78   | \$ 202.13         | \$ 932.32    | \$ 89,348.62    |
|   | 15   | \$ 140.47   | \$ 212.23         | \$ 955.63    | \$ 89,348.62    |
| Post-Exemption  | 16   | \$ 147.49   | \$ 1,202.36       | \$ -         | \$ 89,348.62    |
|   | 17   | \$ 154.87   | \$ 1,237.99       | \$ -         | \$ 89,348.62    |

\*Based on combined permit fees and property values

\*\* Includes estimated value of local utility costs per household: gas & electricity, solid waste, internet, cellphone and estimated sales tax per person.

# Next Steps



- 1. City Council review and comment;**
- 2. Based on Council direction, make amendments as needed to conditional certificate, agreement and resolution;**
- 3. Resolution, conditional certificate, and agreement presented to City Council on December 5, 2022 for approval.**



TO: City Council  
FROM: Tiffany Speir, Long Range & Strategic Planning Manager  
THROUGH: John Caulfield, City Manager *John E. Caulfield*  
DATE: November 28, 2022  
SUBJECT: American Rescue Plan Act (ARPA) Requests for Proposals (RFPs)  
ATTACHMENTS: ARPA RFP Applications (Emergency Food Network (EFN) **Attachment A**, Nourish Pierce County (NPC) **Attachment B**, FOB Hope **Attachment C**, Tacoma Rescue Mission (TRM) **Attachment D**, Living Access Support Alliance (LASA) **Attachment E**)

---

### **BACKGROUND**

On July 25, the City Council provided direction that the City issue American Rescue Plan Act (ARPA) Requests for Proposals (RFPs) for three types of projects:

- Emergency food bank capital costs
- Veterans emergency shelter capital costs
- Permanently low income housing capital construction costs

The RFPs were released in mid-September and five (5) submittals were received:

- two for emergency food bank capital costs;
- two for veteran emergency shelter capital costs; and
- one for permanently low income housing capital costs.

At the September 12 City Council meeting, the Council directed that the amount of funding available for the RFP process would be set at \$5,000,000. The amount requested among the five applications submitted is \$12,208,326. The total amount of ARPA funds not yet obligated is \$6,594,575.

### **RECOMMENDATION**

It is recommended that the City Council review the responses to the RFPs to determine whether to fund any in full or in part, or to seek additional information from current or additional applicants.

The RFP responses are attached hereto:

- Emergency Food Network (EFN) **Attachment A**;
- Nourish Pierce County (NPC) **Attachment B**;
- FOB Hope **Attachment C**;
- Tacoma Rescue Mission (TRM) **Attachment D**; and
- Living Access Support Alliance (LASA) **Attachment E**

**DISCUSSION**

ARPA RFP Applications

The five ARPA RFP submittals were generally responsive to the RFPs issued by the City, with several specific exceptions. The rubric used to conduct an initial review of the applications is described below:

|                                 | GREEN   | YELLOW   | RED   |
|---------------------------------|---|--|---|
| <b>Planning/<br/>Strategic</b>  | Program or project aligns with recommendations in the <a href="#">City's most recent Consolidated Plan (CDBG)</a> . | Program or project related to City goals listed in a City plan or process.   | Not linked to an existing City plan or process.   |
| <b>Transformative</b>           | Makes a permanent and noticeable change in a service or community condition.  | Has potential for noticeable change in a service or community condition, but not fully demonstrated.                     | Demonstrates a short-term or no noticeable change in a service or community condition.                      |
| <b>Scale and<br/>Management</b> | Requesting organization provides same or similar service on a consistent basis.                                     | Requesting organization provides same/similar service on a periodic basis.   | Requesting organization has not previously provided same/similar service.                                   |
| <b>Collaborative</b>            | Partnerships/funding from other organizations have been identified to improve return on investment of proposal.     | Partnerships/funding from other organizations have been requested or are under consideration to improve ROI of proposal. | Does not have partnerships/funding from other organizations to improve ROI of proposal.                     |
| <b>Equity</b>                   | Majority of impact/investment is in disadvantaged communities, businesses, or disparities caused by COVID-19.       | Some impact/investment in disadvantaged communities, businesses, or disparities caused by COVID-19.                      | Little to no impact/investment in disadvantaged communities, businesses, or disparities caused by COVID-19. |

Included below are summaries and the initial, internal scoring of the applications received for each ARPA RFP.

ARPA Risk Assessments:

ARPA rules require that subrecipients' financial stability is reviewed prior to obligating funds to them.

One tool used is the System for Award Management (SAM.gov.) SAM.gov is an official website of the U.S. Government for:

- Registering to do business with the U.S. Government
- Updating, renewing, or checking the status of an entity registration
- Searching for entity registration and exclusion records

- Searching for assistance listings (formerly CFDA.gov), wage determinations (formerly WDOL.gov), contract opportunities (formerly FBO.gov), and contract data reports (formerly part of FPDS.gov).
- Viewing and submitting BioPreferred and Service Contract Reports
- Access publicly available award data via data extracts and system accounts

A SAM.gov finding of “no exclusions” is the needed for ARPA subrecipient eligibility.

A second tool used is a suspension and debarment review.

ARPA staff also reviewed suspension and debarment information for all RFP respondents in compliance with 2017 City of Lakewood Grant requirement policies. Per City policy, no awards or contracts may be made to debarred, suspended or ineligible parties. Before awarding any contracts to be paid in whole or in part by federal funds, the [City] must verify that the contractor is not debarred, suspended or otherwise ineligible to receive federal funds, and documentation of this verification process must be on file.



**Emergency Food Bank Capital Costs (description of projects excerpted from RFP responses):**

Emergency Food Network (EFN):

EFN has requested \$1.5 million of Lakewood ARPA funds to go toward a \$6.3 million project to construct a new 20,000 sq. ft. food warehouse on its Lakewood campus in the Monte Vista neighborhood that would increase EFN's on site storage capacity by 40%. The project is a one-time cost, provides long-lasting benefits to Lakewood residents, is focused on community need, and makes a permanent investment in the city.

EFN has served Lakewood for 40 years; for nearly 20 years, EFN's main campus has been in the Monte Vista neighborhood. EFN has 10 partners in Lakewood and serves more than 200 households in Lakewood each month through its Home Delivery Program. In 2022, it began serving seniors through the Commodity Supplemental Food Program (CSFP) and partnering with Pierce County to serve Ukrainian refugees. Both of these programs serve Lakewood residents. EFN also partners with food pantries in three of Lakewood's Qualified Census Tracts (Lakeview, Springbrook, Tillicum and Woodbrook) and its Home Delivery Program serves all four of Lakewood's QCTs. EFN is also part of Pierce County's emergency management plan.

In order to keep up with the growing need, EFN has had to increase food distribution, including more than 15 million pounds of food annually in 2020 and 2021. Prior to the start of the pandemic, its network served an average of 114,000 visits per month, but the network is currently serving an average of 164,000 visits each month. This is beyond EFN's current storage capacity available in one 17,000 square-foot warehouse and one 3,200 square-foot vertical storage building.

EFN's current warehouses are operating beyond capacity, and it is utilizing additional storage space both on-site in rented and owned trailers and off-site in rented warehouse space in Auburn. This storage space is costing roughly \$12,000 per month. The new warehouse will allow EFN to continue to use its current campus, maintaining operations in Lakewood so that it can serve the entire county. Growing EFN's capacity will provide it with the opportunity to improve programs and create new programs. The new space will become the primary storage space for EFN's food inventory, holding a 30-day food supply.

The new building will also provide a safeguard for the future as EFN's current warehouse is over 70 years old and may need to be significantly remodeled or replaced in the future.

Funding Plan (\$6,300,000 needed total):

**Committed funds: \$3,374,605**

- EFN Reserves, \$1,000,000
- Pierce County ARPA, \$750,000
- Ben B. Cheney Foundation, \$250,000
- Hokold Foundation, \$250,000
- Sequoia Foundation, \$50,000
- EFN Board of Directors, \$88,605 (100% board participation)
- EFN Major Donors, \$561,000
- City of Tacoma, \$225,000
- Bamford Foundation, \$100,000
- Woodworth Family Foundation, \$100,000

**Planned/Pending (Not including City of Lakewood request): Up to \$3,495,000**

- Community Project Funding Request with the Office of Congresswoman Strickland, \$1,500,000
- M.J. Murdock Charitable Trust, \$750,000
- Employee's Community Fund of Boeing, \$500,000
- Norcliffe Foundation, \$250,000
- Individual donors, \$100,000
- Korum for Kids, \$100,000
- Puyallup Tribe, \$100,000
- Treleven Family Foundation, \$50,000
- Puget Sound Energy, \$50,000
- Dimmer Family Foundation, \$25,000
- Baker Foundation, \$25,000
- Forest Foundation, \$25,000
- Medina Foundation, \$20,000

**Scoring:**

|                                   | Planning / Strategic                          | Transformative   | Scale & Management  | Collaborative  | Equity                     | Responsive to RFP?                        |
|-----------------------------------|---|--|---|--|----------------------------|---|
| Emergency Food Bank Capital Costs |   |  |   |  |                            |   |
| EMERGENCY FOOD NETWORK            | CDBG Plan calls for food support to residents | Brings larger scale food assistance distribution in Lakewood | Already running operation, project is for scale, scale is in-line with capabilities | Pierce County ARPA, Ben B. Cheney Foundation, Hokold Foundation, City of Tacoma, Bamford Foundation, Woodworth Family Foundation, Sequoia Foundation | Located in OCT Monte Vista | Capital Food Bank Project within Lakewood |

**EFN ARPA Risk Assessment:**

11/17/22 SAM.gov – no exclusions

11/17/22 suspension and debarment information – no suspension or debarment found

Nourish Pierce County<sup>1</sup>

Nourish Pierce County (NPC or Nourish) is requesting \$2 million of Lakewood ARPA funds to go toward a \$5 million project to purchase and renovate a new location for its food bank.

Nourish Pierce County, (Formerly FISH Food Banks) has been serving in the Lakewood area for 50 years. Over the past 7 years, due to increased need, NPC has expanded its services to four locations. NPC’s mobile food banks visit Clover Park Technical College, Pierce College, and Tillicum/Woodbrook, and it has a brick-and-mortar location at the United Methodist Church at Lakewood. NPC distributes the equivalent of more than 62,640 meals to an average of 6,960 people monthly and consistently serves 14% of the Lakewood population at least one time per year. In the past 8 months, the Lakewood Food Bank has seen 44,500 visitors through the facility – a majority of whom are children and senior.

The Lakewood Food Bank located at the United Methodist Church at Lakewood is one of the busiest locations in NPC’s 21 distribution site network. While the church has been a good partner for over 10 years, this site was never intended to be NPC’s permanent home. The food bank is in a basement that has no exterior doors or elevator. Staff have been moving over 100,000 pounds of food a month in and out of the facility through windows.

After searching for over 6 years, NPC has found a location for a permanent site, and the owner has agreed to sell it to Nourish if it decides to move forward with the purchase. The location is ideal. The nearly two-acre lot and 4,000 sq. ft showroom space would allow Nourish to relocate the Lakewood Food Bank and enable it to pilot an innovative marketplace design and create the next generation of food banks-modeled after modern grocery stores. In addition to a food bank, with additional development, Nourish will be able to develop a Connection Center on-site where other human service & health care organizations can provide wrap-around services & information to food bank customers.

Funding (\$5,000,000 needed total):

| <b>Revenue</b>                    | <b>Income</b>      |
|-----------------------------------|--------------------|
| Individuals                       | \$ 700,000         |
| Corporations                      | \$ 300,000         |
| Foundations                       | \$ 2,000,000       |
| Government Grants (Lakewood ARPA) | \$ 2,000,000       |
| <b>Total Income</b>               | <b>\$5,000,000</b> |

---

<sup>1</sup> To clarify the difference between Nourish Pierce County and the Emergency Food Network (EFN), Nourish’s partner: simply put, EFN is like a distributor while Nourish is a retailer. EFN manages government contracts for commodity food and provides additional food to approximately 70+ subcontracted food banks like Nourish. EFN, Food Lifeline, Northwest Harvest, and others provide food to Nourish who is charged with getting the food into the hands of the people who need it. Nourish operates 21 EFN-subcontracted sites throughout Pierce County, four of which are in Lakewood. As a result, Nourish guests make up approximately 43% of the number of guest visits reported by EFN.

**Scoring:**

|                    | Planning / Strategic                          | Transformative   | Scale & Management  | Collaborative  | Equity  | Responsive to RFP?                        |
|--------------------|---|--|---|--|---|---|
| NOURISH PIERCE CO. | CDBG Plan calls for food support to residents | Brings larger scale food assistance distribution in Lakewood | Already running operation, project is for scale, scale is in-line with capabilities | Collaboration expected, paths to funding identified, no specific partners identified | Well positioned to serve <b>Lakewood's</b> QCTs | Capital Food Bank Project within Lakewood |

**NPC ARPA Risk Assessment:**

11/17/22 SAM.gov – no exclusions

11/17/22 suspension and debarment information – no suspension or debarment found

**Veteran Emergency Shelter Capital Costs (description of projects excerpted from RFP responses):**

FOB Hope:

FOB Hope focuses on unsheltered (those sleeping outside or living in places that are not meant for human habitation) homeless veterans. FOB Hope as proposed two options for ARPA funding for a Veterans Village emergency shelter:

- Option 1 is 25 pallet home shelters with a maximum of 30 villagers;
- Option 2 is 25 ice fishing shelters on platforms with carports to cover them for protection from the elements.

Under either option, the site would provide shower and bathroom facilities as well as handwashing stations and a laundry facility, and there would be common areas for Villagers to utilize for dining and socializing. The model allows for Veterans to live in their own space, helping with the spread of diseases and with the mental wellbeing of those living in the village.

Option 1's budget is set at \$3,208,326 (\$874,029 in year 1 and \$754,099 in years 2, 3, and 4.)

Option 2's budget is set at \$2,862,947 (\$636,755 in year 1 and \$742,064 in years 2, 3, and 4.)

FOB Hope uses a three-pillar focus for its emergency shelters: site services, site security, and site operations. FOB Hope provides the veterans with case management and supportive services. It also provides fencing, 24/7 security, and video cameras on site for the safety of our villagers. FOB Hope utilizes a "self-run" model with oversight from staff, ensuring that there is adequate coverage to maintain the safe and secure daily operations of the village. It provides Veterans with case management and 30/60/90-day plans to get them moving forward with the next chapter of their lives. Other veteran service providers will be invited to the village to assist residents with veterans benefits, housing, employment, and other resources.

FOB Hope was founded in 2016 by a retired United States Army Veteran. It is currently running a Veterans Village in Tacoma, Washington that opened in May of 2022. It has housed 18 veterans by utilizing the Department of Veterans Affairs HUD VASH program and Catholic Community Services Supportive Services for Veteran Families program. FOB Hope has also assisted six veterans with gaining employment.

A resident is entered into our program by qualifying as a veteran of the United States Military. FOB Hope verifies this status through SQUARES, the Department of Veterans Affairs Regional Office located in Seattle, or by ordering the Veterans Form DD 214 (military discharge document) ordered from Archives.gov. Once a person's veteran status is verified, FOB Hope completes a comprehensive intake, which is placed in their housing plan file. The housing file also contains all military documentation, case notes, housing plans, 30/60/90 plans, and incident reports for issues that may occur onsite.

FOB Hope reports Village numbers to the City of Tacoma on a weekly basis. Included in these numbers are the number of veterans housed during the week, the number of veterans residing at the Village, and the total number of veterans we have assisted since the Village opened.

**Funding:**

No other funding has been identified by FOB Hope for this project.

*Note:* FOB Hope has not identified a location for the Veterans Village Lakewood project. The City of Tacoma provided the location for the Tacoma Veterans Village in 2022 and provided infrastructure to the site.

**Scoring:**

|                           | Planning / Strategic                    | Transformative                                    | Scale & Management  | Collaborative   | Equity                         | Responsive to RFP? |
|---------------------------|---|---|---|---|--------------------------------|--------------------|
| Veteran Emergency Shelter |   |   |   |   |                                |                    |
| FOB HOPE                  | CDBG Plan calls for shelter and housing | Temporary housing, benefits services near housing | Scale is small, though unclear if this org is running similar shelters or not | No other partners or funding sources identified. Unclear to what extent funding may be used for general operations of applicant beyond standard % | Targeted @ low-income veterans | No location ID'd   |

**FOB Hope ARPA Risk Assessment:**

11/17/22 SAM.gov – no exclusions

11/17/22 suspension and debarment information – no suspension or debarment found



Tacoma Rescue Mission (TRM):

TRM is requesting \$2 million of Lakewood ARPA funds for a \$49.4 million project titled Pierce County Village Phase I.

As currently proposed, Pierce County Village will be located in unincorporated Pierce County, on an 85.73 acre parcel with 27 buildable acres off of Spanaway Loop Road, less than 5 miles from Lakewood<sup>2</sup>. During Phase I of this project, 150 formerly homeless living units, 21 resident volunteer living units, 3 communal kitchens/multiuse spaces, 6 laundry/shower facilities, and 4 support buildings, including a village commons for large communal gatherings are planned. Project duration of Phase I is November 2022 to Spring 2027. All of the requested Lakewood ARPA funding would be used in the 2023-24 timeframe.

Pierce County Village will not be a shelter or transitional housing as required in the Lakewood RFP, but will free up the capacity of existing shelter and transitional housing, and place chronically homeless, including veterans, in permanent supportive housing. Pierce County Village will welcome, and plans to set aside, 25 microhomes for veterans. Attached is a letter from the VA offering 25 VASH vouchers for Pierce County CFV. Per the 2022 Homeless Point in Time County, 124 veterans are chronically homeless in Pierce County.

Pierce County Village also will not be located within Lakewood as required in the RFP. Pierce County will be located less than 5 miles from the City of Lakewood, and welcome chronically homeless from the City of Lakewood.

Pierce County Village will operate with three overarching rules for residents: be a good neighbor, comply with civil laws, and pay rent. There will be numerous onsite opportunities for microenterprises to empower residents and help them earn income. Both offsite and onsite volunteers will help with activities such as organic farming, cooking, tours, and events. Residents will also be supported by case management, mental healthcare services, and addiction recovery programs.

Since 1912, TRM has been serving people experiencing homelessness, including the chronically homeless. In 2010, TRM opened its family shelter, which now operates as the largest family shelter within Pierce County. As time progresses, TRM adapts to serve the changing needs in our community.

Funding:

\$466,350 in ARPA funds awarded from Pierce County for analysis of a potential Community First Village Pierce County (now called Pierce County Village.) Pierce County Human Services and TRM have a pending request for substantial additional ARPA funding before the County Council for this project.

---

<sup>2</sup> Due to uncertainty regarding the zoning of this parcel of land, the location and timeline for Pierce County Village is subject to change.

**Scoring:**

|  | Planning / Strategic                    | Transformative  | Scale & Management  | Collaborative   | Equity                              | Responsive to RFP?  |
|--|---|---|---|---|-------------------------------------|---|
| TACOMA RESCUE MISSION (updated application submitted after deadline) | CDBG Plan calls for shelter and housing | Pierce County Village (Community First Village model) new to WA State | Project scale is larger than others TRM currently manages. Plan is multi-staged. Current questions re timing of rezoning ID'd property to allow its use or ID of new site and funding release by County Council | 10/28/22: County Council funding release subject to rezone of current site or ID of new site. Lead donors and future private donations, Dept. of Commerce, and other city state & federal monies ID'd as construction fund sources. | Targeted @ all chronically homeless | Project for chronically homeless shelter (not specifically veterans though 25 VASH vouchers dedicated to veterans); located outside of Lakewood |

**TRM ARPA Risk Assessment:**

11/17/22 SAM.gov – no exclusions

11/17/22 suspension and debarment information – no suspension or debarment found

**Permanently Low income Housing Construction Capital Costs**

Living Access Support Alliance (LASA):

LASA is requesting \$3.5 million of Lakewood ARPA funds for Phase 3 of Gravelly Lake Commons, an \$11,412,469 project to construct 25 permanently low income housing units. LASA hopes to obtain partial funding (\$1.5 million) from this application in advance to cover predevelopment costs.

Gravelly Lake Commons will be situated at the corner of Gravelly Lake Dr. SW, 59<sup>th</sup> Street and Fairlawn Drive in Lakewood. When complete the entire complex will feature 55 one-, two- and three-bedroom apartments. The complex will also be home to an affordable day care facility. The development will be situated on a bus line next to LASA’s Client Services Center and within walking distance to a skate park, school, services and shopping.

LASA will require the household be a Pierce County resident and in the 30 to 50% AMI range. Tenancy will be open to populations who may or may not have come from the following populations: DV (Domestic Violence), veterans, new to sobriety and/or have health, or mental health issues. All the units will be set aside for households at 50% or less AMI, with six set aside for those at 30% or less.

With over 30 years of experience working with families experiencing homelessness and households at risk of losing their housing, LASA has the experience to configure the number and size of units to meet the needs of our community. Phase 1 is anticipated to be completed by the Fall of 2026.

Funding:

- Pierce County has pledged \$3.5 million of its ARPA funds to this project. Pierce County will release this portion when all capital funds have been raised.
- LASA has submitted an application to the Department of Commerce Washington State for Housing Trust Fund support (decision pending.)
- Separate from this application for Lakewood ARPA funds, the City of Lakewood is partnering with LASA to seek both state (\$500,000) and federal funding (\$2.5 million) for Gravelly Lake Commons Phase 3\*.

| Source Name                         | Proposed Amount |
|-------------------------------------|-----------------|
| Lakewood ARPA                       | \$ 3,500,000    |
| Lakewood-Partnered State Support*   | \$ 500,000      |
| Lakewood-Partnered Federal Support* | \$ 2,500,000    |
| Tacoma                              | \$ -            |
| Pierce County                       | \$ 3,500,000    |
| WA Housing Trust Fund               | \$ 4,412,469    |
| Permanent Loan                      | \$ -            |

**Total Residential Sources**      **\$ 11,412,469\***

**Scoring:**

|                                       | Planning / Strategic                   | Transformative                            | Scale & Management  | Collaborative  | Equity                | Responsive to RFP?                                   |
|---------------------------------------|--|---|---|--|-----------------------|--|
| Permanently Low Income Housing        |  |   |   |  |                       |  |
| LIVING ACCESS SUPPORT ALLIANCE (LASA) | CDBG Plan calls for low income housing | Permanent housing, amenities near housing | Already running operation, project is for scale, scale is in-line with capabilities | \$3.5M from Pierce County ARPA; pending funding requests to state and federal government | Targeted @ 30-50% AMI | Capital permanent low income housing within Lakewood |

**LASA ARPA Risk Assessment:**

11/17/22 SAM.gov – no exclusions

11/17/22 suspension and debarment information – no suspension or debarment found

## ARPA Funds Update

- The City has received all \$13,766,236 of its ARPA award from the federal government.
- Due to several operational developments, an **estimated \$564,474.02 in funds previously obligated to projects or programs is currently available to reallocate to new, or reallocate to existing, ARPA-eligible expenditures.**<sup>3</sup>
  - o As of November 14, 2022, a total of \$48,715.02 has accrued on the ARPA funds still held by the City. Per the ARPA program rules, the City has discretion to allocate these funds to ARPA-eligible expenditures.
  - o Several ARPA projects completed by October 31, 2022 did not use all of their allocated funds, resulting in \$141,759 available for reallocation:
    - Warrior of Change Youth Leadership Training
    - Code Red Emergency Services Alert & Warning System
    - LPD Retention Bonus
    - HR Temporary Staffing for COVID-19 Tracing
  - o On October 31, 2022 Lakewood received back the \$700,000 bridge loan provided in 2021 to LIHI to purchase Comfort Inn, now operated as Aspen Court.
    - In the near future, LIHI will begin invoicing for the supportive services provided to Lakewood residents of Aspen Court for the years 2022 and 2023. The estimated total cost for the two years of services is \$326,000.
    - The remaining \$374,000 is available for reallocation.

---

<sup>3</sup> Over time, interest will continue to accrue until all ARPA funds have been disbursed by the City. In addition, as ARPA projects are completed, any unused funds will become available for use on other ARPA expenditures through 12/31/26. Actual City administrative costs may also be less than estimated, which would also result in available funds by 12/31/26.

ATTACHMENT A



**City of Lakewood, WA**  
**American Rescue Plan Funding Application**  
**- Food Bank Property Acquisition and/or**  
**Facility Capital Costs -**

6000 Main St SW • Lakewood, WA 98499  
Office Phone: (253) 983.7702 • Email: [tspeir@cityoflakewood.us](mailto:tspeir@cityoflakewood.us)

**Organization Information**

**Legal Name of Organization:** Emergency Food Network of Tacoma and Pierce County

**Doing Business As:** Emergency Food Network, EFN

**Address:** 3318 92nd St South

**city:** Lakewood **zip:** 98499

**Website:** www.efoodnet.org

**Year of Formation:** 1982



|                 | CEO/Executive Director                | Project Coordinator (if different) |
|-----------------|---------------------------------------|------------------------------------|
| Name            | Michelle Douglas                      |                                    |
| Title           | CEO                                   |                                    |
| Email Address   | Michelle@efoodnet.org                 |                                    |
| Phone Number    | 253-584-1040                          |                                    |
| Mailing Address | 3318 92nd St South, Lakewood WA 98499 |                                    |

Taxpayer Identification Number: 94-3131776

UEI Number (Required\*): VZQ4RUJ4J716

\*UEI Number can be obtained [here](#).

Is your Entity registered with [SAM.gov](#) (Required)? Yes  No

If a nonprofit, have you attached a current nonprofit 501(c)(3) tax exempt status, as confirmed by IRS?: Yes  No

I certify that I have the legal authority of the organization represented in this application to submit this request for funding on its behalf, and I further certify that the information submitted in this application is true and correct to the best of my knowledge. I understand that the City of Lakewood will rely on the accuracy of the submittals and certifications made in conjunction with this application. Any misrepresentation of inaccurate information or unused ARPA funds may result in a repayment of funds. If awarded, my organization intends to enter into a contract with the City of Lakewood, provide liability insurance as may be required for the duration of the contract naming the City of Lakewood as an additional insured and in an amount determined by the City.

  
 \_\_\_\_\_  
 SIGNATURE

10/17/2022  
 \_\_\_\_\_  
 DATE

Michelle Douglas, CEO  
 \_\_\_\_\_  
 Print Name and Title

Treasury has updated its guidance to clarify two presumptively eligible ways to use SLFRF to fund affordable housing investments under the final rule.

**SLFRF Affordable Housing Updates at a Glance:**

- **Expanded Presumptive Eligibility.** SLFRF permits funds to be used, among other uses, to combat the public health and negative economic impacts (PH-NEI) of the pandemic. Treasury has updated its guidance to clarify two presumptively eligible ways to use SLFRF to fund affordable housing investments under the final rule.<sup>1</sup>
  - ◊ **Option 1:** SLFRF funds used for affordable housing projects under the PH-NEI eligible use category are presumptively eligible if the project meets certain core requirements of the following expanded list of federal housing programs:
    - National Housing Trust Fund (HTF)
    - HOME Investment Partnerships Program (HOME)
    - Low-Income Housing Credit (LIHTC)
    - Public Housing Capital Fund
    - Section 202 Supportive Housing for the Elderly Program
    - Section 811 Supportive Housing for Persons with Disabilities Program
    - Project-Based Rental Assistance
    - Multifamily Preservation & Revitalization Program
    - Affordable housing projects provided by a Tribal government if they would be eligible for funding under the Indian Housing Block Grant program, the Indian Community Development Block Grant program, or the Bureau of Indian Affairs Housing Improvement Program

<sup>1</sup> Refer to Final Rule FAQs 2.14 and 4.9 for additional information about presumptively eligible affordable housing investments and other program requirements.

The program requirements of these federal housing programs that must be met for presumptive eligibility have been clarified to include four core requirements:

- Resident income restrictions.
  - The affordability period and related covenant requirements for assisted units.
  - Tenant protections, and
  - Housing quality standards.
- ◊ **Option 2:** SLFRF funds used for affordable rental housing under the PH-NEI eligible use category are presumptively eligible uses if the units funded serve households at or below 65% of AMI for a period of 20 years or greater.
  - ◊ A broader range of affordable housing investments may also be eligible uses of SLFRF funds under the final rule if they are related and are reasonably proportional to addressing the negative economic impacts of the pandemic and otherwise meet the final rule's requirements. Depending on the needs of the local rental market, it may be reasonably proportional to address the negative economic impacts of the pandemic by funding units (e.g., up to 80% AMI) that do not fall into the presumptively eligible categories listed above.

**Project Information**

**Please attach additional pages as needed.**

**Project Name:** Building for the Future Campaign

**Total Project/Program Cost:** \$6,300,000

**Amount of ARPA Funds Requested\*:** \$1,500,000

\*Include detailed itemized budget to support amount requested later in this application. Provide any relevant attachments.

**Annual Project/Program Cost to be funded with ARPA Funds (if different than amount above):**  
\_\_\_\_\_

**Have you received other COVID-19 Relief Funding\* related to this project/program?**

Yes  No

\*(e.g., funds from ARPA, CARES Act, other nonprofits, or government)

**If Yes, please provide details on funding:**

\$750,000 from Pierce County ARPA funds and \$225,000 from City of Tacoma ARPA funds  
\_\_\_\_\_

**Estimated Project/Program Schedule: Start Date:** January 2022 **End Date\*:** 12/31/23

\*Per the act, ARPA funds must be fully expended by 12/31/26. **This project's contract may require that its specific funds be fully expended by an earlier date.**

**Project Description:** Emergency Food Network (EFN) requests support for our Building for the Future Campaign. The Building for the Future Campaign is a capital project that will greatly increase our ability to collect, store, and distribute food to our neighbors in need. EFN is Pierce County's nonprofit food distributor, providing our partner food pantries, meal sites, and shelters with a consistent supply of nutritious food. EFN has 10 partners in Lakewood and serves more than 200 households in Lakewood each month through our Home Delivery Program. In 2022, we began serving seniors through the Commodity Supplemental Food Program (CSFP) and we are also partnering with Pierce County to serve Ukrainian refugees. Both of these programs serve Lakewood residents. Programs like CSFP and refugee relief are made possible with capacity investments.

For nearly 20 years, EFN's main campus has been in the Monta Vista neighborhood of Lakewood. Our current warehouses are operating beyond capacity. As a result, we are utilizing additional storage space both on-site in rented and owned trailers and off-site in rented warehouse space in Auburn. Through the Building for the Future Campaign, we will build an additional warehouse on our Lakewood campus. This new warehouse will allow us to continue to use our current campus, maintaining our operations in Lakewood so that we can serve the entire county. Growing our capacity will provide us with the opportunity to improve programs and create new programs to serve Lakewood residents.

**Discuss and describe the community to be addressed through this project/program.**

- **Is your food bank project presumptively eligible under ARPA's Final Rule (see criteria above)?**

Yes  No

**If yes, please describe how it is presumptively eligible (i.e., which criteria it follows from the ARPA**

**Final Rule FAQs):** Treasury recognizes food assistance, including food banks, as one of the enumerated projects in the Final Rule document. In the Final Rule document, Treasury presumes that households that experienced food insecurity have been impacted by the pandemic, which is apparent based on the increased levels of food pantry visits we have seen since 2020. Our campaign will support these households by ensuring that we can continue to provide Lakewood and Pierce County with a reliable food supply. Our project is a one-time cost, provides long-lasting benefits to Lakewood residents, is focused on a community need, and makes a permanent investment in the city. EFN has served Lakewood for 40 years and has been in based in the city for decades.

- **Is the community served a disproportionately impacted community under ARPA?**

EFN meets the Treasury presumption of disproportionately impacted nonprofits as we are located in the Qualified Census Tract (QCT) of Monta Vista. We partner with food pantries in Lakewood's three other QCTs (Lakeview, Springbrook, Tillicum and Woodbrook) and our Home Delivery Program serves all four of Lakewood's QCTs. We serve QCTs throughout Pierce County through our partner food pantries, meal sites, and shelters and through our Home Delivery Program.

- **How will this project or program address the community public health and/or negative economic impacts of COVID-19 (i.e., supporting the health of communities, and helping households, small businesses, impacted industries, nonprofits, and the public sector recover from economic impacts)?**

The Building for the Future Campaign will address the health of our community and help households that have experienced negative economic impacts due to COVID-19. Food is one of the most basic human needs and access to nutritious food is closely tied to individual and community health. As families have lost wages and savings during the pandemic, food pantries were an essential resource to help households meet their most basic needs. Prior to the start of the pandemic, our network served an average of 114,000 visits per month but our network is currently serving an average of 164,000 visits each month.

In order to keep up with the growing need, EFN has had to increase food distribution. We distributed more than 15 million pounds of food annually in 2020 and 2021, pushing our storage space beyond its capacity. Our current storage space consist of two buildings, one 17,000 square-foot warehouse and a 3,200 square-foot vertical storage building. We are currently utilizing multiple temporary storage solutions in order to meet the need in the community. We have stored food on our campus in rented and owned trailers and have rented additional space at a warehouse in Auburn. These solutions cost about \$12,000 each month. Additionally, they make our inventory process more time-consuming and less accurate.

Through the Building for the Future Campaign, we will build an additional warehouse on our lot. The new space will be 20,000 square-feet and will increase our storage capacity by 40%. The new space will become our primary storage space for our inventory, with a 30-day food supply stored in our existing building for immediate distribution. This will create space in our current warehouse so that our team can prepare more orders at a time. With our present space limitations, our team must break midday to prepare orders for the afternoon, which is not an efficient way to manage a warehouse.

The new building will also provide a safeguard for the future. Our current warehouse is more than 70 years old. We have invested in building repairs since purchasing the space nearly 30 years ago, but we know we will need more updates and repairs in the future. If we had to disrupt use of our current warehouse for repairs, it would threaten our ability to continue our work. Building an additional warehouse provides the security that when our older building needs maintenance, we will still be able to serve our partners. EFN is also part of Pierce County's emergency management plan. Just as we led the county's emergency food response during the pandemic, we need to be prepared to respond to future emergencies. The first part of this strategy is bringing our inventory back to one place where it can be accessed immediately. Increasing our storage space is an additional part of our emergency plan as we have seen how quickly the community need can shift, and with it suddenly and dramatically increase the amount of food our network needs.

The legacy of this project will be ensuring that EFN can meet the need of our community for decades to come while operating from our home in Lakewood.

- **Explain your organization’s experience and ability to implement, administer, and manage the proposed project/ program. How will success of this request be measured?**

We conducted a feasibility study over the last two quarters of 2021 in order to prepare for our campaign. Through the study, we identified that building a new warehouse at our Distribution Center in Lakewood is the ideal solution to our storage challenges and long-term agency goals. We hired a Project Manager who has experience with these kinds of projects to help administer and execute the project. We are working with BCRA as our architects due to their commitment to the community and previous experience with these types of projects. Our staff has also been working with other nonprofits, like Gig Harbor FISH, who have recently completed warehouse projects to solicit feedback about these kinds of projects.

We will measure the success of our new warehouse based on our new storage capacity and improvements to efficiency in our warehouse. The storage capacity of our warehouse can be tracked through our monthly inventory process. We will also know the project was a success when we can stop using temporary solutions to meet our long-term storage needs. The new efficiency in our operations will also be tracked through our inventory process and in our daily operations. Our team conducts an inventory of our warehouse twice per month, with the new space we expect to see more accurate inventory counts and a less time consuming process. The new building will also make it possible for our team to build more orders at a time for our partners, reducing how often they need to stop other tasks to build orders. We should see an immediate increase in the number of spaces we have available for orders. Success will be indicated when our team has to spend less time interrupting tasks to build orders, our overall efficiency improves, inventory tracking is more accurate, and all of our food is in one location.

The long-term impact of this project will be its lasting legacy for our operations. A new warehouse will ensure that we can continue to meet the needs of our partners for decades to come. We know that crisis will hit Pierce County again in the future. When the next crisis occurs, we will be more prepared to meet that need and continue our work without serious disruptions.

## PROJECT BUDGET

**Provide a detailed itemized budget below to support amount requested later in this application. Also provide any relevant attachments.**

Estimated costs:

General Requirements: \$470,932  
Sitework: \$582,693  
Building: \$347,875  
Specialty Construction: \$829,000  
Fire Protection: \$182,680  
Plumbing: \$80,300  
HVAC: \$304,636  
Electrical: \$1,041,012  
Soft Costs: \$1,020,609  
Racking and Forklift: \$1,000,000

Total: \$6,300,000

Fundraising Plan:

Committed funds: \$3,374,605  
EFN Reserves, \$1,000,000

Pierce County ARPA, \$750,000  
Ben B. Cheney Foundation, \$250,000  
Hokold Foundation, \$250,000  
City of Tacoma, \$225,000  
Bamford Foundation, \$100,000  
Woodworth Family Foundation, \$100,000  
Sequoia Foundation, \$50,000

EFN Board of Directors, \$88,605 (100% board participation)

EFN Major Donors, \$561,000

Planned/Pending (Not including City of Lakewood request): \$3,495,000

Community Project Funding Request with the Office of Congresswoman Strickland, \$1,500,000  
M.J. Murdock Charitable Trust, \$750,000  
Employee's Community Fund of Boeing, \$500,000  
Norcliffe Foundation, \$250,000  
Korum for Kids, \$100,000  
Puyallup Tribe, \$100,000  
Treleven Family Foundation, \$50,000  
Puget Sound Energy, \$50,000  
Dimmer Family Foundation, \$25,000  
Baker Foundation, \$25,000  
Forest Foundation, \$25,000  
Medina Foundation, \$20,000  
Individual donors, \$100,000



# Building for the Future

## Emergency Food Network Building Campaign



### Our Story

For 40 years, Emergency Food Network (EFN) has provided Pierce County with a consistent, diverse, and nutritious food supply so that no person goes hungry. Originally designed to meet a temporary need caused by the economic recession of the 1980s, it became apparent in the early 1990s that the need for emergency food had grown. In response, EFN became an independent 501(c)(3) non-profit organization in 1991.

Since its conception, EFN has grown from serving 4 food programs to over 70 food programs throughout Pierce County. In 2021, EFN distributed 15,538,416 pounds of food to our partner food programs, an increase of 11% since 2019. This food includes federal and state food, donations, Co-op bulk purchases, and produce from Mother Earth Farm.

The need for food has increased and EFN requires more space to securely and safely store food to feed our neighbors.



**At EFN, we recognize and embrace the ever-changing needs of our community and are actively trying to better identify and meet those needs by ensuring equity, diversity, and inclusion in our staff, board, and partners.**

**In 2021:**

**1 in 9**

Ratio of People Who Are Food Insecure in Pierce County\*



**1.4**

**Million**

People Served through Food Programs in Pierce County

**15.5**

**Million**

Pounds of Food Distributed by EFN

**75+**

Food Pantries, Meal Sites, and Shelters Served by EFN

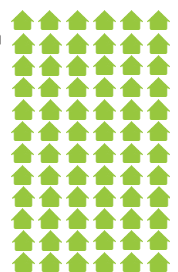

### Building for the Future

While EFN has consistently served the community by providing nourishing food, the need continues to grow. Our current warehouse and footprint can no longer accommodate this rate of growth. We have reached our capacity.

Our current warehouse is 17,000 square-feet with an additional 3,200 square-feet in our 747 warehouse adjacent to our main building. Due to the limitations of this space, we need to shift product to make more room constantly, and our warehouse is unable to operate at maximum efficiency due to this overcrowding. We have been addressing this challenge by storing dry goods in rented trailers located on-site and renting off-site storage. These are not suitable for our long-term operations. The new warehouse will be able to store dry goods increasing our storage capacity by 40%. With this additional storage space we will be able to seek out and purchase more fresh and

frozen produce, protein, and dairy products, the foods most frequently requested by food pantry guests.

EFN purchased the parcel of land where the new warehouse will be built in 2016. The land was purchased as a safeguard for the future to expand our capacity if needed. Over the last two years our role as Pierce County's emergency food distributor has been tested. Our response to the pandemic resulted in distributing an increase of 5 million pounds of food in 2020 (a 36% increase), and starting a Home Delivery Program that serves over 250 families per week. To accommodate these shifts in service, EFN needs to increase our capacity. Your support will help EFN meet the current need and allow us to continue to focus on distributing diverse and nutritious food for years to come.



## Your Place in the Solution

Your investment in this facility will transform EFN's operations. This \$5.3 million capacity-building campaign is currently 59% funded and will result in more space for food, the ability to pick up and deliver more product, a greater connection with our community, neighbors, and partners in meeting our mission and funds for the future to ensure sustained growth.

With your support EFN will meet the ever-growing need in Pierce County and will be positioned to continue our mission into the future. Together, through this capacity building campaign, we will continue to serve the underemployed, the children of families who need our help, and the seniors who depend on us...so that no person goes hungry.

## We can't do this without you.

However you choose to support EFN's Capacity Building Campaign, know that we are tremendously grateful and that the impact of your gift will be profound in serving the needs of our neighbors in need.

# You can help us build for the Future.





GREATER ECONOMIC VITALITY FOR ALL.

Partnering to prepare and grow the Pierce County workforce to align it with employer needs.

April 8, 2022

RE: Emergency Food Network Building for the Future Campaign

To Whom It May Concern,

For 40 years, Emergency Food Network (EFN) has been the backbone of emergency food distribution for food pantries across Pierce County. EFN currently partners with 75+ food pantry partners to serve over 1,400,000 visits from our neighbors in need annually. Through these partnerships, EFN distributes over 15,000,000 pounds of food through their main warehouse in Lakewood to all parts of the county. As part of their commitment to feeding all of Pierce County, EFN also offers Home Delivery to over 250 families each week who have barriers to accessing food pantries. During the pandemic, they were the main supplier of emergency food resources to those most impacted by COVID-19, including those who are underinsured, underemployed, homeless, and marginalized.

It is my pleasure to write this letter in support of Emergency Food Network's Building for the Future campaign, which will build a 22,000+ square foot warehouse at their main campus. Our community relies on adequate and accessible food resources, not just in an emergency, but also on a daily basis. The ability to eat every day is not only essential to survive, but it is also a key component of thriving.

Emergency Food Network has been the central distributor to food pantries in our county for decades. As the holder of the county's most critical contracts, including the federal TEFAP and state EFAP contracts, as well as many others at the city and county level, EFN demonstrates its unique capacity among other organizations in the county. EFN has successfully run these programs by investing in critical infrastructure, such as warehouse space, trucks, staff, facilities, and purchasing power (over \$1,300,000 invested in food annually). This new project will allow them to continue to serve the need for decades to come, whatever the future may bring. It will also greatly increase their efficiency by bringing all of their food supplies to one indoor location, since current overflow inventory goes to offsite warehouses or tractor trailers. Our county needs this crucial investment in the community's safety net—Pierce County needs to be prepared to manage the inflows and outflows of a crisis and have emergency food available when it is needed. The sad truth is that there is not only a food emergency when our community is in crisis. Rather, 1 in 9 of our Pierce County neighbors identifies as food insecure.

In conclusion, I fully support the efforts of Emergency Food Network as they seek funding for their Building for the Future Capacity Campaign. I believe that food is an essential component to survival and that without it, no one can thrive.

Sincerely,

A handwritten signature in blue ink, appearing to read "Katie Condit", is written over a white background.

Katie Condit  
CEO, WorkForce Central



DEREK KILMER  
6TH DISTRICT, WASHINGTON

COMMITTEE ON APPROPRIATIONS  
DEFENSE SUBCOMMITTEE  
INTERIOR, ENVIRONMENT,  
AND RELATED AGENCIES SUBCOMMITTEE  
ENERGY AND WATER  
DEVELOPMENT SUBCOMMITTEE

Congress of the United States  
House of Representatives  
Washington, DC 20515-4706

OFFICES:  
2058 RAYBURN OFFICE BUILDING  
WASHINGTON, DC 20515  
(202) 225-5916

950 PACIFIC AVENUE  
SUITE 1230  
TACOMA, WA 98402  
(253) 272-3515

345 6TH STREET  
SUITE 500  
BREMERTON, WA 98337  
(360) 373-9725

[www.kilmer.house.gov](http://www.kilmer.house.gov)

September 19, 2022

To Whom It May Concern,

I am writing today in support of Emergency Food Network's Building for the Future campaign, which will build a new warehouse at their main campus. The community of Pierce County relies on adequate and accessible food resources, not just in an emergency, but also on a daily basis.

For 40 years, Emergency Food Network (EFN) has been the backbone of emergency food distribution for food pantries across Pierce County. EFN partners with more than 75 food pantries to serve over 1,400,000 visits from their neighbors in need annually. Through these partnerships, EFN distributes over 15,000,000 pounds of food through their main warehouse in Lakewood to all parts of the county. As part of their commitment to feeding all of Pierce County, EFN offers Home Delivery to over 250 families weekly who have barriers to accessing food pantries. During the pandemic, they were the main supplier of emergency food resources to those most impacted by COVID-19, including those who are underinsured, underemployed, homeless, and marginalized.

EFN holds some of the county's most critical contracts, including the federal TEFAP and state EFAP contracts, as well as many others at the city and county level. EFN has successfully run these programs by investing in critical infrastructure, such as warehouse space, trucks, staff, facilities, and purchasing power. This new project will allow them to continue to serve the needs of the community for decades to come. It will also greatly increase their efficiency by bringing all of their food supplies to one indoor location, since current overflow inventory goes to offsite warehouses or tractor trailers. Pierce County needs to be prepared to manage the inflows and outflows and have emergency food available during a crisis and that's why this crucial investment is so important.

Food is an essential component to survival and without it, no one can thrive, and that's why I look forward to the tremendous positive impact that this expansion will have on the surrounding community. I am pleased to offer my support and encouragement for Emergency Food Network's Building for the Future campaign, and I urge your full and fair consideration of their proposal. Should you have any questions, please contact Emma Abraham in my Tacoma Office at (253) 272-3515 or [Emma.Abraham@mail.house.gov](mailto:Emma.Abraham@mail.house.gov).

Sincerely,



Derek Kilmer  
Member of Congress



April 8, 2022

RE: Emergency Food Network Building for the Future Campaign

To Whom It May Concern,

For 40 years, Emergency Food Network (EFN) has been the backbone of emergency food distribution for food pantries across Pierce County. EFN currently partners with 75+ food pantry partners to serve over 1,400,000 visits from our neighbors in need annually. Through these partnerships, EFN distributes over 15,000,000 pounds of food through their main warehouse in Lakewood to all parts of the county. As part of their commitment to feeding all of Pierce County, EFN also offers Home Delivery to over 250 families each week who have barriers to accessing food pantries. During the pandemic, they were the main supplier of emergency food resources to those most impacted by COVID-19, including those who are underinsured, underemployed, homeless, and marginalized.

It is my pleasure to write this letter in support of Emergency Food Network's Building for the Future campaign, which will build a 22,000+ square foot warehouse at their main campus. Our community relies on adequate and accessible food resources, not just in an emergency, but also on a daily basis. **The ability to eat every day is not only essential to survive, but it is also a key component of thriving.**

Emergency Food Network has been the central distributor to food pantries in our county for decades. As the holder of the county's most critical contracts, including the federal TEFAP and state EFAP contracts, as well as many others at the city and county level, EFN demonstrates its unique capacity among other organizations in the county. EFN has successfully run these programs by investing in critical infrastructure, such as warehouse space, trucks, staff, facilities, and purchasing power (over \$1,300,000 invested in food annually). This new project will allow them to continue to serve the need for decades to come, whatever the future may bring. It will also greatly increase their efficiency by bringing all of their food supplies to one indoor location, since current overflow inventory goes to offsite warehouses or tractor trailers. Our county needs this crucial investment in the community's safety net—Pierce County needs to be prepared to manage the inflows and outflows of a crisis and have emergency food available when it is needed. The sad truth is that there is not only a food emergency when our community is in crisis. Rather, 1 in 9 of our Pierce County neighbors identifies as food insecure.

In conclusion, I fully support the efforts of Emergency Food Network as they seek funding for their Building for the Future Capacity Campaign. I believe that food is an essential component to survival and that without it, no one can thrive.

Sincerely,

A handwritten signature in black ink, appearing to read 'Joe Le Roy', with a stylized flourish extending to the right.

Joe Le Roy  
President & CEO



Celebrating 40 years of feeding our neighbors

...so that no person goes hungry.

April 8, 2022

RE: Emergency Food Network Building for the Future Campaign

To Whom It May Concern,

For 40 years, Emergency Food Network (EFN) has been the backbone of emergency food distribution for food pantries across Pierce County. EFN currently partners with 75+ food pantry partners to serve over 1,400,000 visits from our neighbors in need annually. Through these partnerships, EFN distributes over 15,000,000 pounds of food through their main warehouse in Lakewood to all parts of the county. As part of their commitment to feeding all of Pierce County, EFN also offers Home Delivery to over 250 families each week who have barriers to accessing food pantries. During the pandemic, they were the main supplier of emergency food resources to those most impacted by COVID-19, including those who are underinsured, underemployed, homeless, and marginalized.

It is my pleasure to write this letter in support of Emergency Food Network's Building for the Future campaign, which will build a 22,000+ square foot warehouse at their main campus. Our community relies on adequate and accessible food resources, not just in an emergency, but also on a daily basis. **The ability to eat every day is not only essential to survive, but it is also a key component of thriving.**

Emergency Food Network has been the central distributor to food pantries in our county for decades. As the holder of the county's most critical contracts, including the federal TEFAP and state EFAP contracts, as well as many others at the city and county level, EFN demonstrates its unique capacity among other organizations in the county. EFN has successfully run these programs by investing in critical infrastructure, such as warehouse space, trucks, staff, facilities, and purchasing power (over \$1,300,000 invested in food annually). This new project will allow them to continue to serve the need for decades to come, whatever the future may bring. It will also greatly increase their efficiency by bringing all of their food supplies to one indoor location, since current overflow inventory goes to offsite warehouses or tractor trailers. Our county needs this crucial investment in the community's safety net—Pierce County needs to be prepared to manage the inflows and outflows of a crisis and have emergency food available when it is needed. The sad truth is that there is not only a food emergency when our community is in crisis. Rather, 1 in 9 of our Pierce County neighbors identifies as food insecure.

In conclusion, I fully support the efforts of Emergency Food Network as they seek funding for their Building for the Future Capacity Campaign. I believe that food is an essential component to survival and that without it, no one can thrive.

Sincerely,







Celebrating 40 years of feeding our neighbors

...so that no person goes hungry.

### Community Endorsements

Mayor Woodards  
*Tacoma, WA*

Mayor Whalen  
*Lakewood, WA*

Deputy Mayor Ushka  
*Tacoma, WA*

Councilmember Morell  
*Pierce County, District #1*

Councilmember Zeiger  
*Pierce County, District #2*

Councilmember Mello  
*Pierce County, District #4*

Councilmember Campbell  
*Pierce County, District #5*

Councilmember Hitchen  
*Pierce County, District #6*

Councilmember Young  
*Pierce County, District #7*

Kathi Littman  
*President and CEO  
Greater Tacoma Community  
Foundation*

Dona Ponepinto  
*President and CEO  
United Way of Pierce County*

Erika Tucci  
*Senior Program Officer  
Ben B. Cheney Foundation*

Sue Potter  
*CEO at Nourish Pierce County*

Craig Ueland  
*Ueland Foundation*

Mike Tucci  
*Tucci and Sons*

Mark Winter  
*CEO and Owner  
WinSource Group*

Doug Baxter-Jenkins  
*Community Integration Program  
Manager  
Virginia Mason Franciscan Health*

Brianne Tyler  
*Senior Manager  
Stonebridge Valuation, LLC.*

Ingrid Gourley Mungia  
*Executive Director of Government  
Relations  
MultiCare Health System*

Alice Phillips  
*Business Manager/Financial  
Secretary  
IBEW Local 483*

Andrea Tull Davis  
*Senior Director of Government  
and External Relations,  
Coordinated Care*

Julie Jordan-Walsh  
*Human Resources Manager,  
Boeing Company*

Pete Lantz  
*Director of Sales  
Raymond West*

Sharon Snuffin  
*President  
Snuffin's Catering*

Kevin Healey  
*Telecom Engineer  
TrueBlue Inc.*

Eric Gilman  
*Partner  
Gordon Thomas Honeywell, LLP*

Julie Boyd  
*Assistant Director Treasury and  
Cash Management  
Cambia Health Solutions*

Chad Maiuri  
*SVP South Sound District  
Manager  
Heritage Bank*





June 29, 2022

**Jason Whalen**  
Mayor

Representative Marilyn Strickland, 10<sup>th</sup> District  
6000 Main Street SW, Suite 3B  
Lakewood, WA 98499

**Mary Moss**  
Deputy Mayor

Dear Congresswoman Strickland:

**Don Anderson**  
Councilmember

This letter is to express to you the City of Lakewood's support for funding the Emergency Food Network's (EFN's) Building for the Future Campaign. Through this campaign, EFN will build a second warehouse at our Distribution Center in Lakewood. EFN provides food to multiple food pantries located in Lakewood HUD and ARPA Qualified Census Tracts including but not limited to:

**Patti Belle**  
Councilmember

- Prince of Peace in the city of Lakewood (Tract 718.05);
- Tillicum/American Lake Gardens Community Center (Tract 729.07); and
- Nourish Pierce County and St. Leo's Food Connection, with mobile food pantries serving Tillicum and Springbrook.

**Paul Bocchi**  
Councilmember

Lakewood residents also access EFN food pantries across its network in Pierce County. In 2021, EFN's partner food pantries in Lakewood served more than 106,000 total visitors, and EFN provided these partners with more than one million pounds of food. Partner programs within the QCTs of Lakewood served more than 19,000 visitors, and EFN provided these partners with more than 250,000 pounds of food.

**Michael D. Brandstetter**  
Councilmember

**Linda Farmer**  
Councilmember

Adding a new warehouse will expand EFN's storage capacity by 40% so that it can continue to meet the needs in the community. During the COVID-19 pandemic, EFN has had to rent off-site storage space and utilize trailers to expand its inventory to reflect the growth in need for food assistance. However, these solutions have resulted in additional monthly costs and reduce efficiency in EFN's warehouse. The warehouse team has to manage an inventory stored across multiple locations and must drive to the offsite location in order to maintain an adequate amount of food in its Lakewood Distribution Center.

**John J. Caulfield**  
City Manager

Thank you for your efforts to secure federal funding for EFN's Building for the Future Campaign - this vital service for Lakewood and Pierce County residents will truly change people's lives.

Sincerely,

John Caulfield, City Manager

ATTACHMENT B



City of Lakewood, WA  
American Rescue Plan Funding Application  
- Food Bank Property Acquisition and/or  
Facility Capital Costs -

6000 Main St SW • Lakewood, WA 98499  
Office Phone: (253) 983.7702 • Email: [tspeir@cityoflakewood.us](mailto:tspeir@cityoflakewood.us)

**Organization Information**

**Legal Name of Organization:**

FISH Food Banks of Pierce County

**Doing Business As:**

Nourish Pierce County

**Address:** 1702 South 72<sup>nd</sup> Street, Suite E

**City:** Tacoma **Zip:** 98408

**Website:** Nourishpc.org

**Year of Formation:** 1983

|                        |  |
|------------------------|--|
| <b>Name</b>            | Sue Potter   |
| <b>Title</b>           | Chief Executive Officer                              |
| <b>Email Address</b>   | SuePotter@Nourishpc.org                              |
| <b>Phone Number</b>    | 253-507-7309   |
| <b>Mailing Address</b> | 1702 S. 72 <sup>nd</sup> St. Ste E, Tacoma, WA 98408 |

**Taxpayer Identification Number:** 91-1198-391

**UEI Number (Required\*):** HBA1VTDXNBE4

\*UEI Number can be obtained [here](#).

**Is your Entity registered with [SAM.gov](#) (Required)?** Yes XX No

If a nonprofit, have you attached a current nonprofit 501(c)(3) tax exempt status, as confirmed by IRS?: Yes XX No \_\_\_\_\_

I certify that I have the legal authority of the organization represented in this application to submit this request for funding on its behalf, and I further certify that the information submitted in this application is true and correct to the best of my knowledge. I understand that the City of Lakewood will rely on the accuracy of the submittals and certifications made in conjunction with this application. Any misrepresentation of inaccurate information or unused ARPA funds may result in a repayment of funds. If awarded, my organization intends to enter into a contract with the City of Lakewood, provide liability insurance as may be required for the duration of the contract naming the City of Lakewood as an additional insured and in an amount determined by the City.

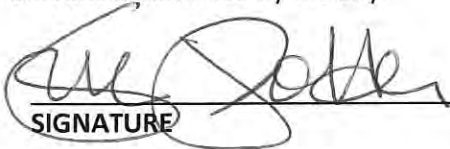
  
\_\_\_\_\_  
SIGNATURE

10/17/25  
DATE

Sue Potter, CEO  
\_\_\_\_\_  
Print Name and Title



Treasury has updated its guidance to clarify two presumptively eligible ways to use SLFRF to fund affordable housing investments under the final rule.

**SLFRF Affordable Housing Updates at a Glance:**

- **Expanded Presumptive Eligibility.** SLFRF permits funds to be used, among other uses, to combat the public health and negative economic impacts (PH-NEI) of the pandemic. Treasury has updated its guidance to clarify two presumptively eligible ways to use SLFRF to fund affordable housing investments under the final rule.<sup>1</sup>
  - **Option 1:** SLFRF funds used for affordable housing projects under the PH-NEI eligible use category are presumptively eligible if the project meets certain core requirements of the following expanded list of federal housing programs:
    - National Housing Trust Fund (HTF)
    - HOME Investment Partnerships Program (HOME)
    - Low-Income Housing Credit (LIHTC)
    - Public Housing Capital Fund
    - Section 202 Supportive Housing for the Elderly Program
    - Section 811 Supportive Housing for Persons with Disabilities Program
    - Project-Based Rental Assistance
    - Multifamily Preservation & Revitalization Program
    - Affordable housing projects provided by a Tribal government if they would be eligible for funding under the Indian Housing Block Grant

<sup>1</sup> Refer to Final Rule FAQs 2.14 and 4.9 for additional information about presumptively eligible affordable housing investments and other program requirements.

program, the Indian Community Development Block Grant program, or the Bureau of Indian Affairs Housing Improvement Program

The program requirements of these federal housing programs that must be met for presumptive eligibility have been clarified to include four core requirements:

- Resident income restrictions;
  - The affordability period and related covenant requirements for assisted units;
  - Tenant protections; and
  - Housing quality standards.
- **Option 2:** SLFRF funds used for affordable rental housing under the PH-NEI eligible use category are presumptively eligible uses if the units funded serve households at or below 65% of AMI for a period of 20 years or greater.
  - A broader range of affordable housing investments may also be eligible uses of SLFRF funds under the final rule if they are related and are reasonably proportional to addressing the negative economic impacts of the pandemic and otherwise meet the final rule's requirements. Depending on the needs of the local rental market, it may be reasonably proportional to address the negative economic impacts of the pandemic by funding units (e.g., up to 80% AMI) that do not fall into the presumptively eligible categories listed above.

## Project Information

**Please attach additional pages as needed.**

**Project Name:** Property Acquisition for a new Lakewood Nourish Food Bank

**Total Project/Program Cost:** \$5,000,000

**Amount of ARPA Funds Requested\*:** \$2,000,000

\*Include detailed itemized budget to support amount requested later in this application. Provide any relevant attachments.

**Annual Project/Program Cost to be funded with ARPA Funds (if different than amount above):**

N/A – Request is for capital funding only

**Have you received other COVID-19 Relief Funding\* related to this project/program?**

Yes  No

\*(e.g., funds from ARPA, CARES Act, other nonprofits, or government)

**If Yes, please provide details on funding:**

---

---

**Estimated Project/Program Schedule: Start Date:** January, 2023 **End Date\*:** December, 2023

\*Per the act, ARPA funds must be fully expended by 12/31/26. This project's contract may require that its specific funds be fully expended by an earlier date.

### **Project Description:**

Nourish Pierce County, (Formerly FISH Food Banks) has been serving in the Lakewood area for 50 years. As the largest food bank in the county, Nourish operates more food distribution sites than any other organization in the state. Our mission is simple - provide nutritious food and support services to those in need with compassion, dignity, and respect. No one in need is turned away.

The Lakewood Nourish Food Bank needs a new home so that our legacy of service in the community can continue. Over the past 7 years, we have seen the need for our services in Lakewood grow as a result, we have expanded our services to four locations. Our mobile food banks visits Clover Park Technical College, Pierce College, Tillicum/Woodbrook and we have a brick-and-mortar location at the United Methodist Church at Lakewood. Nourish now consistently serves 14% of the Lakewood population at least one time per year.

The Lakewood Food Bank located at the United Methodist Church at Lakewood is one of the busiest locations in our network of twenty-one distribution sites. While the church has been a good partner for over 10 years, this site was never intended to be our permanent home. The food bank is in a basement that has no exterior doors or elevator. We have been moving over 100,000 pounds of food a month in and out of the facility through windows. It is back-breaking, dangerous work. Customers who cannot navigate the stairs must have a Nourish volunteer or friends shop for them and do not get the dignity of choosing items that they might make their meals more enjoyable. For over 6 years we have searched for a permanent home in Lakewood and have had no luck. We just have not been able to be competitive in the commercial real estate market. Recently this

changed. We were made aware of a site that could serve Nourish and the citizens of Lakewood well for the next 50 years, The Mattress Ranch property on the corner of Lakewood Avenue and Steilacoom Blvd. While this property is not listed as for sale, the owner has agreed to sell it to Nourish if we decide to move forward with the purchase. The location is ideal. The nearly two-acre lot and 4,000 sq. ft showroom space would allow Nourish to relocate the Lakewood Food Bank and enable us to pilot an innovative marketplace design and create the next generation of food banks—modeled after modern grocery stores. Our goal is to develop the facility to look more like a contemporary, commercial retail store vs the antiquated version of a food bank. Whether one drives by or stops to use our services, the facility will be designed to remove the visual stereotype of food banks. The interior will raise our customers' experience by providing a “normal” shopping environment. Our vision is to provide customers and the community with a food bank that they can be proud of. In addition to a food bank, with additional development, Nourish will be able to develop a Connection Center on-site where other human service & health care organizations can provide wrap-around services & information to food bank customers.

**Discuss and describe the community to be addressed through this project/program.**

- **Is your food bank project presumptively eligible under ARPA’s Final Rule (see criteria above)?**

Yes      No **XX** \*\*

**If yes, please describe how it is presumptively eligible (i.e., which criteria it follows from the ARPA Final Rule FAQs):**

This is not an affordable housing project. It is for Basic Needs- Food banks. The project and programs that will be based out of this facility *are* in alignment with the recommendations in the City’s most recent Consolidated Plan. (CDBG) as stated in section 1.4.2 which addresses “Protecting the Social, Economic, and Natural Environments”. This project also speaks to the City’s commitment to “Provide access to adequate and affordable housing, medical and community services and safety nets, healthy food and alternative transportation in all areas of the city.” In addition, “*providing basic needs*”, “*healthy food*”, “*developing a network of services that respond to community needs*”, “*fostering self-sufficiency*”, “*supporting, and actively coordinating with local, regional, and national efforts that address local human service’s needs*”, have all been listed as goals in section 8.9.

- **Is the community served a disproportionately impacted community under ARPA?**

The Lakewood Nourish Food Bank serves the entire Lakewood community including those recognized by ARPA as “Hardest Hit” which includes QTC Tracts 720.00,718.05,718.06, 718.08, and717.04.

During the pandemic, Nourish helped an unprecedented number of people. We helped those who were suddenly laid off with no idea if their jobs would ever return. With schools closed, we helped families provide for their children who would otherwise receive free/reduced meals during the school week. We also helped ensure that senior citizens did not have to choose between buying food and their medication.

More people are struggling to make ends meet as inflation and supply chain delays have caused food prices to increase dramatically. In the past 8 months, The Lakewood Food Bank has seen 44,500 visitors through the facility— a majority of whom are children and seniors. While the economic future is unknown, our community continues to need Nourish.

- **How will this project or program address the community public health and/or negative economic impacts of COVID-19 (i.e., supporting the health of communities, and helping households, small businesses, impacted industries, nonprofits, and the public sector recover from economic impacts)?**

*"I had a job. I had a home. I got sick and lost everything."*

*-- Sheila Dent, Lakewood Client & Volunteer.*

We all need food to survive, and we need nutritious food to live healthy and productive lives. For example, children need healthy food to be successful in school and seniors need healthy food to avoid hospitalization or institutionalization. How well we provide sustenance for the most vulnerable people in our society reflects our humanity, compassion, and cultural values. If Nourish did not provide services at the Lakewood food bank, over 13,700 people would have to look elsewhere for nutritious food. As the population has grown, so has the number of food-insecure people. 1 in 9 residents are food insecure. Sadly, at Joint Base Lewis McChord, 1 out of 5 active-duty members of the military must choose between food and rent, food and medicine, food and childcare, or are skipping meals so that others in the household can eat. Our guests are our neighbors. They are the working poor, the unemployed, students, those on disability, active-duty military, veterans, and anyone else who finds themselves in need.

Every week at the Lakewood Nourish Food Bank, we distribute healthy food to sustain everyone's rightful pursuit of food security, dignity, and ultimately, health and prosperity. Nourish distributes the equivalent of more than 62,640 meals to an average of 6,960 people monthly.

After nearly a half-century of resourceful and innovative service in Lakewood, Nourish Pierce County is expanding its impact. Through this project, we are redefining the concept of healthy food access for neighbors in need in the ever-changing economic landscape.

**Our Mission:** To provide nutritious food and support services for people in need with compassion, dignity, and respect.

**Our Vision:** Providing pathways from scarcity to security.

While there are other food banks in Lakewood, none have served as long or as many as Nourish. Often there is confusion around the difference between Nourish and The Emergency Food Network (EFN), our organization's partner. Simply put—EFN is like a distributor while Nourish is a retailer. EFN manages government contracts for commodity food and provides additional food to approximately 70+ subcontracted food banks like Nourish. EFN, Food Lifeline, Northwest Harvest, and others provide food to Nourish who is charged with getting the food into the hands of the people who need it. Nourish operates 21 EFN subcontracted sites throughout the county, four of which are in Lakewood. As a result, Nourish guests make up approximately 43% of the number of guest visits reported by EFN. Our organizations depend upon each other in our efforts to end hunger in Pierce County.

**Explain your organization's experience and ability to implement, administer, and manage the proposed project/ program. How will success of this request be measured?**

The leadership team at Nourish Pierce County has over 50 years of combined experience in non-profit management including large capital campaigns and managing government contracts.

Sue Potter is the CEO of Nourish, a \$13 million nonprofit network of food pantries in Pierce County, Washington. Along with the Board of Directors, Sue is responsible for the strategic direction of Nourish as it



works to provide nutritious food to all in need with compassion, dignity, and respect. During her 32-year career in nonprofit development and administration, Sue has worked for local organizations such as Habitat for Humanity and the University of Puget Sound. If you have visited the Museum of Glass or Charles Wright Academy in Tacoma, you have seen the results of some of the capital campaigns she completed. Sue has a B.A. degree in Communications from The University of Arizona and is currently working towards a master's degree in Business and Leadership. Sue and her husband Bill reside in Lakewood. In 2021 Sue was the Recipient of the Washington Association of School Administrators Community Leadership Award- Bethel School District. She is active in the community as a Senior Fellow, of the American Leadership Forum Class XX, A mentor for students at the University of Puget Sound Business Leadership Program, The Lakewood representative on the Pierce County Conservation Futures Community Advisory Board, President-Elect of the Rotary Club of Clover Park, and a member, National Society of Leadership and Success Honor Society.

Ken Gibson is Nourish Pierce County's Deputy Director. Ken's role is to oversee Nourish Pierce County's development, marketing, and communications efforts, as well as its community outreach program, which includes volunteers, AmeriCorps members, and partnerships with local businesses and organizations. In addition, he works with CEO, Sue Potter, on policy, strategic direction, and related administrative activities. Ken holds a Masters in Nonprofit Leadership from Seattle University and a Bachelor of Arts in Political Science from Pacific Lutheran University. Ken has thirty-five years of nonprofit experience and has held leadership roles in such organizations as Washington Masonic Charities, TACID, Metro Parks Tacoma/Metro Parks Foundation, Point Defiance Zoological Society, and Pacific Science Center. He played an instrumental role in the successful \$84 million Metro Parks Tacoma bond campaign in 2006. Ken has served on the Pierce Transit Community Advisory Board, and the Pierce County Voting Accessibility Advisory Committee. He was recognized as the City of Tacoma Disability Advocate of the year in 2012. Ken currently serves on the Board of Directors for the World Civility Council.

## PROJECT BUDGET

Provide a detailed itemized budget below to support amount requested later in this application. Also, provide any relevant attachments.

| Revenue   | Income              | Notes   |
|---|---------------------|---|
| Individuals   | \$ 700,000          |   |
| Corporations  | \$ 300,000          |   |
| Foundations   | \$ 2,000,000        |   |
| Government Grants   | \$ 2,000,000        |   |
| <b>Total Income</b>   | <b>\$ 5,000,000</b> |   |
| Expenses  | Estimated Costs     | Notes   |
| Property Purchase   | \$ 3,900,000        |   |
| Renovations/Safety  | \$ 350,000          | Add fire suppression, removal of structures and mechanical that are not up to code.   |
| Permits/Fees  | \$ 35,000           |   |
| Structural, electrical, mechanical, & other Professional Services | \$ 300,000          |   |
| Furnishings & Fixtures  | \$ 350,000          | Walk-in cooler & freezer, retail refrigeration, shelving, signage (outdoor), flooring |
| Technology  | \$ 20,000           |   |
| Contingency   | \$ 45,000           |   |
| <b>TOTAL EXPENSE</b>  | <b>\$ 5,000,000</b> |   |



# City of Lakewood, WA

## American Rescue Plan Funding Application

### - Veterans Emergency Shelter Capital Costs -

6000 Main St SW • Lakewood, WA 98499

Office Phone: (253) 983.7702 • Email: [tspeir@cityoflakewood.us](mailto:tspeir@cityoflakewood.us)

### Organization Information

**Legal Name of Organization:** FOB Hope

**Doing Business As:** FOB Hope

**Address:** STE 700-250  
1625 E. 72<sup>nd</sup> Street

**City:** Tacoma

**Zip:** 98404

**Website:** [www.fobhope.org](http://www.fobhope.org)

**Year of Formation:** 2016

|                        | <b>CEO/Executive Director</b>                              | <b>Project Coordinator (if different)</b>           |
|------------------------|--|---|
| <b>Name</b>            | Monique Brown  | Tammy Creley  |
| <b>Title</b>           | Founding Executive Director                                | Chief Operations Officer                            |
| <b>Email Address</b>   | <a href="mailto:MBrown@fobhope.org">MBrown@fobhope.org</a> | Tammyc@fobhope.org                                  |
| <b>Phone Number</b>    | 253.970.4431   | 253.732.2652  |
| <b>Mailing Address</b> | 1822 1/2 S. Cloverdale Avenue, Los Angeles, CA 90019       | 1018 21 <sup>st</sup> Street SW, Puyallup, WA 98371 |

**Taxpayer Identification Number:** 81-3325838

**UEI Number (Required\*):** NBXWU5569CY5

\*UEI Number can be obtained [here](#).

**Is your Entity registered with [SAM.gov](https://www.sam.gov) (Required)?** Yes  No

**If a nonprofit, have you attached a current nonprofit 501(c)(3) tax exempt status, as confirmed by IRS?:** Yes  No

I certify that I have the legal authority of the organization represented in this application to submit this request for funding on its behalf, and I further certify that the information submitted in this application is true and correct to the best of my knowledge. I understand that the City of Lakewood will rely on the accuracy of the submittals and certifications made in conjunction with this application. Any misrepresentation of inaccurate information or unused ARPA funds may result in a repayment of funds. If awarded, my organization intends to enter into a contract with the City of Lakewood, provide liability insurance as may be required for the duration of the contract naming the City of Lakewood as an additional insured and in an amount determined by the City.

  
 \_\_\_\_\_  
 SIGNATURE

09/29/2022  
 DATE

Monique Brown, Executive Director  
 Print Name and Title



**Project Information**

**Please attach additional pages as needed.**

**Project Name:** FOB Hope’s Veterans Village #2

**Total Project/Program Cost:** Option 1: \$3,208,326 OR Option 2: \$2,862,947

**Amount of ARPA Funds Requested\*:** Option 1: \$3,208,326 OR Option 2: \$2,862,947

\*Include detailed itemized budget later in this application to support amount requested. Provide any relevant attachments.

**Annual Project/Program Cost to be funded with ARPA Funds (if different than amount above):**

Year 1 = Option 1: \$874,029 OR Option 2: \$636,755

Years 2, 3, and 4 = Option 1: \$754,099 Annually OR Option 2: \$742,064 Annually

**Have you received other COVID-19 Relief Funding\* related to this project/program?**

Yes \_\_\_ No **X**

\*(e.g., funds from ARPA, CARES Act, other nonprofits, or government)

**If Yes, please provide details on funding:**

\_\_\_\_\_  
\_\_\_\_\_

**Estimated Project/Program Schedule: Start Date:** June 1, 2023 **End Date\*:** December 31, 2026

\*Per the act, ARPA funds must be fully expended by 12/31/26. **This project’s contract may require that its specific funds be fully expended by an earlier date.**

**Project Description:**

FOB Hope’s Veterans Village is an emergency shelter for Veterans of the United States military who are living homeless. We use a three-pillar focus for our emergency shelters. The focuses are site services, site security, and site operations. The Village will contain (Option 1) 25 Pallet Home shelters (maximum of 30 villagers) for Veterans to reside in until they can be moved into permanent housing. Option 2 is 25 Ice Fishing Shelters on platforms with carpports to cover them for protection from the elements. The site will also provide shower and bathroom facilities as well as handwashing stations and a laundry facility. There will also be common areas for Villagers to utilize for dining and socializing. FOB Hope provides the Veterans with case management, and supportive services. Additionally, other Veteran service providers will be invited to the Village to assist residents with Veterans benefits, housing, employment, and other resources.

FOB Hope provides fencing, 24/7 security, and video cameras on site for the safety of our Villagers. Although FOB Hope utilizes a “self-run” model with oversight from staff, we ensure there is adequate coverage to maintain the safe and secure daily operations of the Village.

**Discuss and describe the community to be addressed through this project/program.**

Only 7% of the US population serves in the United States Military. Estimates state that approximately 40,000 of those who served are living homeless. Ironically, 7% of those living homeless in Pierce County Washington are Veterans. Pierce County has approximately 327

homeless Veterans and 254 of those Veterans are living unsheltered. 24 of the unsheltered Veterans in Pierce County live in Lakewood, Washington. The population of Veterans living homeless is the demographic FOB Hope focuses on. Specifically, those Veterans who are living unsheltered.

The numbers above are from a count done on one night at the beginning of each year. They are the means in which the County determines the number of community members who are living homeless. However, those who work in social services are aware a precise count is almost impossible to make. Although the count says that 24 Veterans are living unsheltered in Lakewood, this number is more than likely not accurate.

FOB Hope wants to be instrumental in getting unsheltered Veterans off the street and into permanent housing. We want to ensure every person who served this Country in the military has a safe and secure place to live. FOB Hope believes there is nothing worse than having served your Country and then coming home to have no place to call home!

- **Is your veteran emergency shelter/transitional housing project presumptively eligible under ARPA's Final Rule (see criteria above)?**

Yes  No

**If yes, please describe how it is presumptively eligible (i.e., which criteria it follows from the ARPA Final Rule FAQs):**

The ARPA Final Rule allows for funding for those impacted by COVID – 19. Many people lost their housing and employment during the pandemic. FOB Hope's Veterans Village focuses on those who were negatively impacted in this way. Our program focuses on getting Veterans living homeless immediately off the street. Although, we are not providing rental units, we are providing a free safe place for Veterans to reside until we can get them back into permanent housing.

- **Is the community served a disproportionately impacted community under ARPA?**

Veterans of the United States Military have disproportionately been impacted by homelessness. We can also note that Veterans of color have been impacted disproportionately by homelessness as well. According to HUD, during 2020 and 2021 the number of sheltered homeless Veterans decreased by 10%. This is the largest decline since 2015-2016. HUD also states that 15% of homeless individuals were unsheltered between 2020 and 2021. Veterans represented 7%.

- **How will this project or program address the community public health and/or negative economic impacts of COVID-19 (i.e., supporting the health of communities, and helping households, small businesses, impacted industries, nonprofits, and the public sector recover from economic impacts)?**

COVID-19 impacted many people in the United States. Americans lost their jobs during that time. Unfortunately, many Veterans work in service industries and those were hit the hardest

during the time of COVID-19. It is said that drugs, alcohol, and domestic violence numbers were also elevated during the pandemic. Veterans are more susceptible to these issues due to their time in service. The combination of these issues resulted in the increase of homelessness amongst Veterans. FOB Hope's Veterans Village addresses the housing loss, loss of employment, and more. Our Pallet Shelter and ice fishing tent models allow for Veterans to live in their own space. This helps with the spread of diseases and helps with the mental wellbeing of those living in the Village. Our program helps employ community members who also may have lost work during COVID-19. Additionally, many nonprofits, including ours have lost funding since the COVID funding that was plentiful in 2021 stopped at the beginning of the year. The economy has also changed and donations to small nonprofit organizations have dropped considerably. Receiving funding to assist Veterans living homeless will also assist FOB Hope with keeping its doors open.

- **Explain your organization's experience and ability to implement, administer, and manage the proposed project/ program. How will success of this request be measured?**

FOB Hope was founded in 2016 by a retired United States Army Veteran. Our organization began with the mission of locating Veterans living on the street with the objective of referring them to resources and the benefits they earned through their service to this country. We also referred them to housing providers to help get them off the street. We still do this work from time to time; however, FOB Hope is currently running a Veterans Village in Tacoma, Washington. We no longer need to refer Veterans to other service providers for emergency/transitional housing. We can put them directly into our Veterans Village.

FOB Hope's Veterans Village opened in May of 2022. Since that time, we have housed 18 Veterans by utilizing the Department of Veterans Affairs HUD VASH program and Catholic Community Services Supportive Services for Veteran Families program. We have also assisted six Veterans with gaining employment.

Our concept to provide Veterans with a safe place to live and transition into permanent housing has been working thus far. We provide Veterans with case management and 30/60/90-day plans to get them moving forward with the next chapter of their lives. Most of our Veterans are thriving in this environment, as we remain fluid in our approach to assisting them.

The Villager is entered into our program by qualifying as a Veteran of the United States Military. We check this status through SQUARES, The Department of Veterans Affairs Regional Office located in Seattle, or by ordering the Veterans Form DD 214 (military discharge document) ordered from Archives.gov. Once we approve Veteran status we complete a comprehensive intake, which is placed in their housing plan file. The housing file also contains all military documentation, case notes, housing plans, 30/60/90 plans, and incident reports for issues that may occur onsite. These documents are locked in a file cabinet in the staff office.

Our Key Performance Indicators (KPI's) are the number of Veterans who we assist with:

- gaining housing
- retaining housing

- gaining employment
- signing up and receiving Veterans benefits
- getting state identification / state driver's license's
- opportunities for socialization

FOB Hope reports Village numbers to the City of Tacoma on a weekly basis. Included in these numbers are the number of Veterans housed during the week, the number of Veterans residing at the Village, and the total number of Veterans we have assisted since the Village opened.



## PROJECT BUDGET

Provide a detailed itemized budget below to support amount requested later in this application. Also provide any relevant attachments.

### OPTION 1: PALLET SHELTERS

| Line     | Projected Budget  | June- Dec<br>2023 | 2024             | 2025             | 2026             | Total Budget       |
|----------|---|-------------------|------------------|------------------|------------------|--------------------|
| 1        | Program Administrator (Executive Leadership) 2 FTE                      | \$45,000          | \$90,000         | \$90,000         | \$90,000         | \$315,000          |
| 2        | Site Operations Manager (1 FTE) (\$30/hr)                               | \$31,200          | \$62,400         | \$62,400         | \$62,400         | \$218,400          |
| 3        | Case Manager (2 FTE) (\$26)   | \$54,080          | \$108,160        | \$108,160        | \$108,160        | \$378,560          |
| 4        | Administrative Assistant (1 FTE) (\$24/hr)                              | \$24,960          | \$49,920         | \$49,920         | \$49,920         | \$174,720          |
| 5        | Site Security (5 FTE / 1 On-Call) (\$20/hr)                             | \$104,000         | 208,000          | \$208,000        | \$208,000        | \$728,000          |
| 6.       | Transportation (1 FTE) (\$20/ hr)                                       | \$20,800          | \$41,600         | \$41,600         | \$41,600         | \$145,600          |
| 6        | Administrative Indirect Costs (Payroll costs State and Federal = 12.6%) | \$44,877          | \$104712         | \$104712         | \$104712         | \$359,013          |
| <b>7</b> | <b>Personnel</b>  | <b>\$252,917</b>  | <b>\$664,792</b> | <b>\$664,792</b> | <b>\$664,792</b> | <b>\$2,319,293</b> |
| 9        | Shelter 64 SQF 1.5" Insulated (x20)                                     | \$199,900         |                  |                  |                  | \$199,900          |
| 10       | Shelter 100 SAF 1.5" Insulated (x5)                                     | \$59,975          |                  |                  |                  | \$59,975           |
| 11       | Folding Bunk Bed (x30)  | \$10,470          |                  |                  |                  | \$10,470           |
| 12       | Custom Fit Mattress Pad (x30)   | \$8,970           |                  |                  |                  | \$8,970            |
| 13       | 120v Electrical Kit w/1500w Heater                                      | \$1,299           |                  |                  |                  | \$1,299            |
| 14       | Assembly Services (x25)   | \$22,500          |                  |                  |                  | \$22,500           |
| 15       | Sales Tax   | \$30,611          |                  |                  |                  | \$30,611           |
| 16       | Shipping and Handling   | \$6,000           |                  |                  |                  | \$6,000            |
| 17       | Sleeping Bags   | \$2,000           | \$250            | \$250            | \$250            | \$2,750            |
| 18       | Blankets  | \$999             | \$499            | \$499            | \$499            | \$2,496            |
| 19       | Pillows   | \$400             | \$200            | \$200            | \$200            | \$1,000            |
| 20       | Carport (for Kitchen 20x20x7)   | \$4,300           |                  |                  |                  | \$4,300            |

|              |  |                  |                 |                 |                 |                    |
|--------------|--|------------------|-----------------|-----------------|-----------------|--------------------|
| 21           | Storage Sheds (x6) (10' x 8')  | \$9174           |                 |                 |                 | \$9,174            |
| 22           | Internet   | \$600            | \$1,200         | \$1,200         | \$1,200         | \$4,200            |
| 23           | Initial Set Up (security cameras, first aid kit, cigarette disposal containers, file cabinets, tables/chairs, common area appliances, common area furniture, tools, miscellaneous) | \$8,388          |                 |                 |                 | \$8,388            |
| 24           | Technology (Laptops)   | \$8,000          |                 |                 |                 | \$8,000            |
| 25           | Software Subscriptions   | \$2,225          | \$4,450         | \$4,450         | \$4,450         | \$15,575           |
| 26           | Insurance  | \$1944           | \$3,888         | \$3,888         | \$3,888         | \$13,608           |
| 27           | Supplies (disposable cutlery, Kitchen items, garbage bags, hand sanitizer, shelf stable food, etc.)  | \$4,800          | \$5,000         | \$5,000         | \$5,000         | \$19,800           |
| 28           | Office Supplies  | \$6,319          | \$2,000         | \$2,000         | \$2,000         | \$12,319           |
| 29           | Mileage (Outreach)   | \$2,600          | \$5,200         | \$5,200         | \$5,200         | \$ 18,200          |
| 30           | Client Support (Transportation, bus/train fare, DOL fees, etc.) Daily Meaningful Activities  | \$13,469         | \$26,938        | \$26,938        | \$26,938        | \$94,283           |
| 31           | Temporary Financial Assistance (move-in-costs)   | \$19,091         | \$38,182        | \$38,182        | \$38,182        | \$133,637          |
| 32           | Uniforms   | \$2,000          | \$1,500         | \$1,500         | \$1,500         | \$6,500            |
| 33           | Laundry Trailor (7 Stations)   | \$88,000         |                 |                 |                 | \$88,000           |
| 34           | Office Trailor   | \$5,529          |                 |                 |                 | \$5,529            |
| 35           | 2 Stall Bathroom Unit (Toilet, Shower, Sink)   | \$44,995         |                 |                 |                 | \$44,995           |
| 36           | 2 Stall Accessible Bathroom Unit (1 Full Bath, 1 Admin Bath)   | \$42,995         |                 |                 |                 | \$42,995           |
| 37           | Bathroom Shipping and Tax  | \$12,099         |                 |                 |                 | \$12,099           |
| 38           | Propane Storage Cage (x2)  | \$1,460          |                 |                 |                 | \$1,460            |
| 39           | <b>Non-Personnel</b>   | <b>\$621,112</b> | <b>\$89,307</b> | <b>\$89,307</b> | <b>\$89,307</b> | <b>\$889,033</b>   |
| <b>Total</b> |  |                  |                 |                 |                 | <b>\$3,208,326</b> |

**OPTION 2: ICE FISHING SHELTERS**

| Line | Projected Budget  | 2023             | 2024             | 2025             | 2026             | Total Budget       |
|------|---|------------------|------------------|------------------|------------------|--------------------|
| 1.   | Program Administrator (Executive Leadership)<br>2 FTE   | \$45,000         | \$90,000         | \$90,000         | \$90,000         | \$315,000          |
| 2.   | Site Operations Manager (1 FTE) (\$30/hr)   | \$31,200         | \$62,400         | \$62,400         | \$62,400         | \$218,400          |
| 3.   | Case Manager (2 FTE) (\$26)   | \$54,080         | \$108,160        | \$108,160        | \$108,160        | \$378,560          |
| 4.   | Administrative Assistant (1 FTE) (\$24/hr)  | \$24,960         | \$49,920         | \$49,920         | \$49,920         | \$174,720          |
| 5.   | Site Security (5 FTE / 1 On-Call) (\$20/hr)   | \$104,000        | 208,000          | \$208,000        | \$208,000        | \$728,000          |
| 6.   | Transportation (1 FTE) (\$20/ hr)   | \$20,800         | \$41,600         | \$41,600         | \$41,600         | \$145,600          |
| 7.   | Administrative Indirect Costs (Payroll costs<br>State and Federal = 12.6%)  | \$40,045         | \$93,440         | \$93,440         | \$93,440         | \$320,365          |
|      | <b>Personnel</b>  | <b>\$320,085</b> | <b>\$653,520</b> | <b>\$653,520</b> | <b>\$653,520</b> | <b>\$2,280,645</b> |
| 8.   | Ice Fishing Shelters (x25)  | \$12,000         | \$2,400          | \$2,400          | \$2,400          | \$19,200           |
| 9.   | Metal Carports (10'W x 20'L x 7' H)   | \$16,802         |                  |                  |                  | \$16,802           |
| 10.  | Carport (for Kitchen 20x20x7)   | \$4,300          |                  |                  |                  | \$4,300            |
| 11.  | Cots  | \$2,200          | \$275            | \$275            | \$275            | \$3,025            |
| 12.  | Sleeping Bags   | \$2,000          | \$250            | \$250            | \$250            | \$2,750            |
| 13.  | Blankets  | \$999            | \$499            | \$499            | \$499            | \$2,496            |
| 14.  | Pillows   | \$400            | \$200            | \$200            | \$200            | \$1,000            |
| 15.  | Platforms   | \$6,000          |                  |                  |                  | \$6,000            |
| 16.  | Storage Sheds (x6) (10' x 8')   | \$9,174          |                  |                  |                  | \$9,174            |
| 17.  | Internet  | \$600            | \$1,200          | \$1,200          | \$1,200          | \$4,200            |
| 18.  | Initial Set Up (security cameras, first aid kit,<br>cigarette disposal containers, file cabinets,<br>tables/chairs, common area appliances,<br>common area furniture, tools, miscellaneous) | \$8,388          |                  |                  |                  | \$8,388            |
| 19.  | Technology (Laptops)  | \$8,000          |                  |                  |                  | \$8,000            |
| 20.  | Software Subscriptions  | \$2,225          | \$4,450          | \$4,450          | \$4,450          | \$15,575           |
| 21.  | Insurance   | \$1944           | \$3,888          | \$3,888          | \$3,888          | \$13,608           |
| 22.  | Supplies (disposable cutlery, Kitchen items,<br>garbage bags, hand sanitizer, shelf stable<br>food, etc.)   | \$4,800          | \$5,000          | \$5,000          | \$5,000          | \$19,800           |
| 23.  | Office Supplies   | \$6,319          | \$2,000          | \$2,000          | \$2,000          | \$12,319           |
| 24.  | Mileage (Outreach)  | \$881            | \$1,762          | \$1,762          | \$1,762          | \$6,167            |
| 25.  | Client Support (Transportation, bus/train fare,<br>DOL fees, etc.) Daily Meaningful Activities  | \$13,469         | \$26,938         | \$26,938         | \$26,938         | \$94,283           |
| 26.  | Temporary Financial Assistance (move-in-<br>costs)  | \$19,091         | \$38,182         | \$38,182         | \$38,182         | \$133,637          |
| 27.  | Uniforms  | \$2,000          | \$1,500          | \$1,500          | \$1,500          | \$6,500            |
| 28.  | Laundry Trailor (7 Stations)  | \$88,000         |                  |                  |                  | \$88,000           |
| 29.  | Propane Storage Case  | \$1,460          |                  |                  |                  | \$1,460            |
| 30.  | Office Trailor  | \$5,529          |                  |                  |                  | \$5,529            |
| 31.  | 2 Stall Bathroom Unit (Toilet, Shower, Sink)  | \$44,995         |                  |                  |                  | \$44,995           |
| 32.  | 2 Stall Accessible Bathroom Unit (1 Full Bath,<br>1 Admin Bath)   | \$42,995         |                  |                  |                  | \$42,995           |

|              |                           |                  |                 |                 |                 |                    |
|--------------|---------------------------|------------------|-----------------|-----------------|-----------------|--------------------|
| 33.          | Bathroom Shipping and Tax | \$12,099         |                 |                 |                 | \$12,099           |
|              | <b>Non-Personnel</b>      | <b>\$316,670</b> | <b>\$88,544</b> | <b>\$88,544</b> | <b>\$88,544</b> | <b>\$582,302</b>   |
| <b>Total</b> |                           |                  |                 |                 |                 | <b>\$2,862,947</b> |

<https://home.treasury.gov/system/files/136/July-2022-PE-Report-User-Guide.pdf>

3. **Capital Expenditures:** For projects reported under the Project Expenditure Categories EC1: Public Health, EC2: Negative Economic Impact and EC3: Public Health-Negative Economic Impact: Public Sector Capacity, **provide answers to the following questions (refer to Figure IV - 19):**

- Does this project include a capital expenditure?
- If “Yes”:
  - i. What is the total expected cost of the capital expenditure, including pre-development costs, if applicable?
  - ii. Type of capital expenditure, based on the following enumerated uses (as noted in [Appendix H](#))
- If the answer is “No”, include a zero for the expected total cost of the capital expenditure
- **For recipients (other than Tribal governments) investing in projects with total expected capital expenditures for an enumerated eligible use of \$10 million or more,**

**Coronavirus State and Local Fiscal Recovery Funds:**  
Project and Expenditure Report User Guide

31



U.S. DEPARTMENT OF THE TREASURY

- **as well as projects with total expected capital expenditures for an “other” use of \$1 million or more, provide a written justification.** (This field is required in July 2022.)
- For projects with total expected cost of the capital expenditures of over \$10 million, provide labor reporting as outlined for infrastructure projects on pages 24, 26, and 27 of the Reporting Guidance. (These fields are required in July 2022.)

**From:** Monique Brown [mailto:mbrown@fobhope.org]  
**Sent:** Monday, November 14, 2022 3:44 PM  
**To:** Tiffany Speir <tspeir@cityoflakewood.us>; Tammy Creley <Tammyc@fobhope.org>  
**Cc:** Ted Thelin <TThelin@cityoflakewood.us>  
**Subject:** Re: Update re pending RFPs from City of Lakewood

**This email originated outside the City of Lakewood.**

Use caution when following links or opening attachments as they could lead to malicious code or infected web sites.  
When in doubt, please contact the HelpDesk.

- [helpdesk@cityoflakewood.us](mailto:helpdesk@cityoflakewood.us) ext. 4357

---

Hello Ted,

FOB Hope has a contract with King County to provide services as the Pathfinder Coordinator. The purpose of that contract is to train Pathfinders and coordinate outreach efforts for levy funded organizations that work with Veterans.

We also have a contract with the City of Tacoma to run an emergency shelter for Veterans living street homeless. Our model provides case management, housing plans, assistance with employment, and connections to housing under the HUD VASH program and SSVF. The contract is temporary, but they say they are willing to discuss extending the contract past 2023.

We were also conducting outreach in both counties but did not have contracts for this work. We were working on a volunteer basis.

Please let me know if you have any further questions.

Respectfully,

Monique Brown, USA(Ret.), MNPL  
Founding Director, FOB Hope  
King County Pathfinder Coordinator  
Pronouns: She/Her/Hers  
[mbrown@fobhope.org](mailto:mbrown@fobhope.org)  
253.970.4431



*Hope Changes Everything*

---

**From:** Tiffany Speir <[tspeir@cityoflakewood.us](mailto:tspeir@cityoflakewood.us)>  
**Sent:** Monday, November 14, 2022 13:16  
**To:** Monique Brown <[mbrown@fobhope.org](mailto:mbrown@fobhope.org)>; Tammy Creley <[Tammyc@fobhope.org](mailto:Tammyc@fobhope.org)>  
**Cc:** Ted Thelin <[TThelin@cityoflakewood.us](mailto:TThelin@cityoflakewood.us)>  
**Subject:** RE: Update re pending RFPs from City of Lakewood



Hi Monique and Tammy:

Can you provide a list of the project FOB Hope is running or has run in Pierce and King Co?

Thank you,

---

Tiffany Speir, Esq., CPM®  
Long Range & Strategic Planning Manager  
ARPA Program Manager  
City of Lakewood  
253.983.7702 | [tspeir@cityoflakewood.us](mailto:tspeir@cityoflakewood.us)

**From:** Monique Brown [<mailto:mbrown@fobhope.org>]  
**Sent:** Friday, September 16, 2022 1:34 PM  
**To:** Tiffany Speir <[tspeir@cityoflakewood.us](mailto:tspeir@cityoflakewood.us)>  
**Subject:** Re: Update re pending RFPs from City of Lakewood

**This email originated outside the City of Lakewood.**

Use caution when following links or opening attachments as they could lead to malicious code or infected web sites.  
When in doubt, please contact the HelpDesk.

- [helpdesk@cityoflakewood.us](mailto:helpdesk@cityoflakewood.us) ext. 4357

---

I just saw this message! I have been doing too much these days.

My question is regarding infrastructure. The Village FOB Hope runs now was funded by the City of Tacoma. They did all infrastructure and pay for ongoing services. Will this be the way Lakewood will operate?

Respectfully,

Monique Brown, USA(Ret.), MNPL  
Founding Director, FOB Hope  
King County Pathfinder Coordinator  
Pronouns: She/Her/Hers  
[mbrown@fobhope.org](mailto:mbrown@fobhope.org)  
253.970.4431



*Hope Changes Everything*



## Veterans Village Community Agreement

1. No violence to yourselves or others
2. No theft
3. No persistent, disruptive behavior
4. Everyone must contribute to the operation and maintenance of the Village

I will be a positive member of this community and contribute toward making it a safe, secure, clean, and pleasant place to live. Therefore, I agree to the following:

- What I do will be based on love and respect for myself and others.
- I will not disrespect others based on ethnicity, religion, gender, sexual orientation, disability, lifestyle choices, or economic status. We all have the right to expect dignity and opportunity.
- I will help make this a place where everyone feels safe and respected. For my own safety as well as the safety of others, I will not carry a weapon or act violently toward others or myself.
- Since stealing is one of the most upsetting things that can happen in our community, I will not steal and will make the members of the Village Council aware of any stealing I see. I will respect other people's property and community property and I expect other people to respect mine.
- I will honor quiet hours from 2200 hours to 0700 hours so that others and myself can stay healthy and rested. I understand that no personal guests will be allowed during that time.



- I want to live in a clean, litter-free, comfortable space where I can bring friends, family, and other guests. Also, I know that many communities such as ours get shut down for “health and safety” reasons. I will keep the area in and around where I live clean and orderly, and not store any personal items outside of my dwelling footprint or allocated storage space. I will help keep the community areas clean and will pick up after myself and my pet, if I have one.
  
- I understand, to maintain a secure environment, there will be a single point of entrance and exit that will be staffed 24/7, and that security shifts will be shared equally among FOB residents.
  
- I know that it can take a lot of work to keep the FOB a safe, clean, and pleasant place to live. I agree to work at least 10 hours a week on the operation and maintenance of the Village. This includes serving on security teams, helping with kitchen duties, construction projects, maintenance, and clean-up crews, helping plan activities, and other jobs that need to be shared by community members.
  
- I will attend the weekly FOB meetings, unless I have an acceptable reason for absence, in which case I will find out what went on by reading the meeting notes. I understand that decisions will be made through a majority vote, and that the Board of Directors of the non-profit reserves the right to override decisions made. I agree to abide by all decisions made.
  
- I promise to keep all agreements, as well as others that are approved at FOB meetings. If I violate any agreements, the members of the FOB Council are authorized to ask me to leave temporarily, or, in serious or repeat cases, to leave permanently. I will do so peacefully and not return unless I am authorized to do so.



I know that FOB Hope Veterans Village is a place where people value community and support each other. I will try to think of ways to make our community a better place to be. When I am concerned or upset with situations at the FOB, I will bring these problems to the attention of the appropriate people so that we can work together to figure things out. I willingly sign these agreements that are a contract between FOB Hope Veterans Village and me.

Print Name: \_\_\_\_\_

Signature: \_\_\_\_\_

Date: \_\_\_\_\_





**FOB Hope Veterans Village**  
**Client Intake and Referral (Confidential)**

|   |   |  |                  |
|---|---|--|------------------|
| <b>Section 1. Veterans Information</b>  |   |  |                  |
| VETERAN NAME: Last, First, MI   | GENDER<br>Choose an item.   | DATE OF BIRTH / AGE<br>Click or tap here to enter text.  | LAST FOUR OF SSN |
| RACE / ETHNICITY (CHECK ALL THAT APPLY)   |   |  |                  |
| <input type="checkbox"/> LATINO (A)(X) <input type="checkbox"/> BLACK (NOT LATINO (A/X)) <input type="checkbox"/> WHITE (NOT LATINO (A/X)) <input type="checkbox"/> AMERICAN INDIAN / ALASKA NATIVE<br><input type="checkbox"/> ASIAN <input type="checkbox"/> NATIVE HAWAIIAN OR PACIFIC ISLANDER <input type="checkbox"/> OTHER: Click or tap here to enter text. |   |  |                  |
| LAST KNOWN HOME ADDRESS   | CITY  | STATE  | ZIP CODE         |
| VETERAN PHONE NUMBER<br>Click or tap here to enter text.  | VETERAN EMAIL ADDRESS<br>Click or tap here to enter text.   |  |                  |
| EMERGENCY CONTACT NAME: Click or tap here to enter text.  | EMERGENCY CONTACT PHONE NUMBER: Click or tap here to enter text.  |  |                  |
| MARITAL STATUS: Divorced  | IS VETERAN NATIVE AMERICAN? IF YES, AFFILIATION<br><input type="checkbox"/> YES <input type="checkbox"/> NO    Click or tap here to enter text.   |  |                  |
| <b>Section 2. Military Information</b>  |   |  |                  |
| TYPE OF MILITARY SERVICE<br><br><input type="checkbox"/> Active Duty<br><input type="checkbox"/> Reserves<br><input type="checkbox"/> National Guard  | PERIOD OF SERVICE<br>Entry Year:    Click or tap here to enter text.<br>Separation Year:    Click or tap here to enter text.<br>Still Active: <input type="checkbox"/> Yes <input type="checkbox"/> No<br>Federal Deployments: <input type="checkbox"/> Yes <input type="checkbox"/> No<br>If Yes, Theater of Operations: Choose an item. |  |                  |
| DISCHARGE STATUS<br>Choose an item.   | BRANCH OF SERVICE<br>Choose an item.  |  |                  |
| DO YOU HAVE A COPY OF YOUR DD 214<br><input type="checkbox"/> Yes <input type="checkbox"/> No   | IF NO, ORDERED BY FOB HOPE STAFF?: <input type="checkbox"/> Yes <input type="checkbox"/> No<br>DATE: Click or tap to enter a date.    Method: Choose an item.   |  |                  |
| <b>Section 3. Education</b>   |   |  |                  |
| Highest Level of Education Completed:    Choose an item.  |   |  |                  |
| Employment Status: Unemployed   |   |  |                  |
| <b>Section 4. Source(s) of Income</b>   |   |  |                  |
| SNAP: <input type="checkbox"/> Yes <input type="checkbox"/> No<br>If Yes, Amount: Click or tap here to enter text.  | TANF: <input type="checkbox"/> Yes <input type="checkbox"/> No<br>If Yes, Amount: Click or tap here to enter text.  | VA Disability: <input type="checkbox"/> Yes <input type="checkbox"/> No<br>If Yes, Amount: \$                      |                  |
| VA Pension: <input type="checkbox"/> Yes <input type="checkbox"/> No<br>If Yes, Amount: Click or tap here to enter text.  | SSI: <input type="checkbox"/> Yes <input type="checkbox"/> No<br>If Yes, Amount: Click or tap here to enter text.   | SSDI: <input type="checkbox"/> Yes <input type="checkbox"/> No<br>If Yes, Amount: Click or tap here to enter text. |                  |
| Earned Income: <input type="checkbox"/> Yes <input type="checkbox"/> No<br>If Yes, Employer Information<br>Click or tap here to enter text.   | Monthly Household Income:<br><br>\$   |  |                  |
| <b>Section 5. Insurance</b>   |   |  |                  |
| Health Insurance: <input type="checkbox"/> Yes <input type="checkbox"/> No<br>If Yes, Type of Insurance:<br>Other:  | Dental Insurance: <input type="checkbox"/> Yes <input type="checkbox"/> No<br>If Yes, Type of Insurance: Choose an item.  |  |                  |
| <b>Section 6. Disabilities</b>  |   |  |                  |
| Do you have any disabilities that require accommodations?<br><input type="checkbox"/> Yes <input type="checkbox"/> No. If yes, what are those accommodations?<br>Mobility – Hernia, shoulder, toe, peptic ulcer   | Do you need assistance connecting to services for disability accommodations?<br><input type="checkbox"/> Yes <input type="checkbox"/> No. If yes, please explain further    Click or tap here to enter text.  |  |                  |
| Do any of your physical disabilities limit the type of housing you could access? Yes <input type="checkbox"/> No <input type="checkbox"/> N/A. If yes, please explain: quiet housing needed   |   |  |                  |
| Do any of your mental health disabilities limit your ability to live alone?    Yes <input type="checkbox"/> No <input type="checkbox"/> N/A   |   |  |                  |
| <b>Section 7. Supplemental Questions</b>  |   |  |                  |
| How long has it been since you lived in permanent stable housing? September 2021  |   |  |                  |

|   |  |
|---|--|
| In the last three years, how many times have you been homeless? Three times   |  |
| Do you have any legal issues going on right now? <input type="checkbox"/> Yes <input type="checkbox"/> No. If yes, please explain: Click or tap here to enter text.   |  |
| Do you have any evictions on your record? <input type="checkbox"/> Yes <input type="checkbox"/> No. If yes, what year: Click or tap here to enter text.   |  |
| Do you owe a landlord money due to an eviction? <input type="checkbox"/> Yes <input type="checkbox"/> No. If yes, who and how much: Click or tap here to enter text.  |  |
| Are you currently able to take care of basic needs like bathing, changing clothes, using the restroom, and other things like that? <input type="checkbox"/> Yes <input type="checkbox"/> No                           |  |
| Have you ever been convicted as a sex offender? <input type="checkbox"/> Yes <input type="checkbox"/> No. If Yes, Level Choose an item. Registry Commitment: <input type="checkbox"/> Yes <input type="checkbox"/> No |  |
| <b>Section 8. Assessor Information / Village Information</b>  |  |
| First and Last Name: Click or tap here to enter text.   | Date: Click or tap here to enter text. |
| ROI Complete: <input type="checkbox"/> Yes <input type="checkbox"/> No. If no, reason Click or tap here to enter text.  |  |
| Signed Community Agreement: <input type="checkbox"/> Yes <input type="checkbox"/> No. (Failure to sign the agreement will disqualify the applicant for Village entry)   |  |
| Does the Veteran have a pet? <input type="checkbox"/> Yes <input type="checkbox"/> No. If yes, Type Click or tap here to enter text.  |  |
| Where was the Veteran staying before they came to the Village? Click or tap here to enter text.   |  |
| What is the Veterans tent space number? Click or tap here to enter text.  |  |
| Does the Veteran have items in Village storage? Click or tap here to enter text.  |  |
| Does the Veteran have a car at the Village? <input type="checkbox"/> Yes <input type="checkbox"/> No.   |  |
| If Yes, make / model / license plate number: Click or tap here to enter text.   |  |
| Did you give the Veteran a Village parking ID card? <input type="checkbox"/> Yes <input type="checkbox"/> No. If yes, enter the card number Click or tap here to enter text.  |  |
| <b>Section 9. Exit Information</b>  |  |
| Reason for Exit: Choose an item.  |  |
| Exit Date: Click or tap here to enter text.   |  |



INTERNAL REVENUE SERVICE  
P. O. BOX 2508  
CINCINNATI, OH 45201

DEPARTMENT OF THE TREASURY

Date:

AUG 14 2017

FOB HOPE  
C/O MONIQUE BROWN  
339 BURNETT AVE S 316  
RENTON, WA 98057

Employer Identification Number:  
81-3325838

DLN:

17053130341027

Contact Person:

SHERRI L ROYCE

ID# 31653

Contact Telephone Number:

(877) 829-5500

Accounting Period Ending:

December 31

Public Charity Status:

170(b)(1)(A)(vi)

Form 990/990-EZ/990-N Required:

Yes

Effective Date of Exemption:

December 22, 2015

Contribution Deductibility:

Yes

Addendum Applies:

No

Dear Applicant:

We're pleased to tell you we determined you're exempt from federal income tax under Internal Revenue Code (IRC) Section 501(c)(3). Donors can deduct contributions they make to you under IRC Section 170. You're also qualified to receive tax deductible bequests, devises, transfers or gifts under Section 2055, 2106, or 2522. This letter could help resolve questions on your exempt status. Please keep it for your records.

Organizations exempt under IRC Section 501(c)(3) are further classified as either public charities or private foundations. We determined you're a public charity under the IRC Section listed at the top of this letter.

If we indicated at the top of this letter that you're required to file Form 990/990-EZ/990-N, our records show you're required to file an annual information return (Form 990 or Form 990-EZ) or electronic notice (Form 990-N, the e-Postcard). If you don't file a required return or notice for three consecutive years, your exempt status will be automatically revoked.

If we indicated at the top of this letter that an addendum applies, the enclosed addendum is an integral part of this letter.

For important information about your responsibilities as a tax-exempt organization, go to [www.irs.gov/charities](http://www.irs.gov/charities). Enter "4221-PC" in the search bar to view Publication 4221-PC, Compliance Guide for 501(c)(3) Public Charities, which describes your recordkeeping, reporting, and disclosure requirements.

Letter 947



FOB HOPE

Sincerely,

*Stephen a. martin*

Director, Exempt Organizations  
Rulings and Agreements

Letter 947





# City of Lakewood, WA

## American Rescue Plan Funding Application

### - Veterans Emergency Shelter Capital Costs -

6000 Main St SW • Lakewood, WA 98499  
Office Phone: (253) 983.7702 • Email: [tspeir@cityoflakewood.us](mailto:tspeir@cityoflakewood.us)

### Organization Information

Legal Name of Organization: The Rescue Mission

Doing Business As: Tacoma Rescue Mission

Address: 425 S Tacoma Way

City: Tacoma

Zip: 98402

Website: www.trm.org

Year of Formation: 1912

|                 | CEO/Executive Director        | Project Coordinator (if different) |
|-----------------|-------------------------------|------------------------------------|
| Name            | Duke Paulson                  | ↔                                  |
| Title           | Executive Director            | ↔                                  |
| Email Address   | dukep@trm.org                 | ↔                                  |
| Phone Number    | 253-383-4493 x1129            | ↔                                  |
| Mailing Address | PO Box 1912, Tacoma, WA 98401 | ↔                                  |

Taxpayer Identification Number: 91-0565014

UEI Number (Required\*): QXHN4U8ZMB85

\*UEI Number can be obtained [here](#).

Is your Entity registered with [SAM.gov](#) (Required)? Yes  No

If a nonprofit, have you attached a current nonprofit 501(c)(3) tax exempt status, as confirmed by IRS? Yes  No

I certify that I have the legal authority of the organization represented in this application to submit this request for funding on its behalf, and I further certify that the information submitted in this application is true and correct to the best of my knowledge. I understand that the City of Lakewood will rely on the accuracy of the submittals and certifications made in conjunction with this application. Any misrepresentation of inaccurate information or unused ARPA funds may result in a repayment of funds. If awarded, my organization intends to enter into a contract with the City of Lakewood, provide liability insurance as may be required for the duration of the contract naming the City of Lakewood as an additional insured and in an amount determined by the City.

  
 \_\_\_\_\_  
 SIGNATURE

10/17/22  
 DATE

Duke Paulson, Executive Director  
 Print Name and Title

**Project Information**  
**Please attach additional pages as needed.**

**Project Name:** Community First Village Pierce County – Phase I

**Total Project/Program Cost:** \$49.4 million

**Amount of ARPA Funds Requested\*:** \$2,000,000

\*Include detailed itemized budget later in this application to support amount requested. Provide any relevant attachments.

**Annual Project/Program Cost to be funded with ARPA Funds (if different than amount above):** Pending

**Have you received other COVID-19 Relief Funding\* related to this project/program?**

**Yes** No

\*(e.g., funds from ARPA, CARES Act, other nonprofits, or government)

**If Yes, please provide details on funding:**

\$466,350 in ARPA funds awarded from Pierce County for analysis of a potential Community First Village Pierce County. Pierce County Human Services and TRM have a pending request for substantial additional ARPA funding before the County Council for this project.

**Estimated Project/Program Schedule: Start Date:** November 2022 **End Date\*:** Spring 2027

\*Per the act, ARPA funds must be fully expended by 12/31/26. **This project's contract may require that its specific funds be fully expended by an earlier date.**

**Project Description:**

People experiencing chronic homelessness, as defined by the US Department of Housing and Urban Development, are among the most vulnerable of our neighbors in need. They have been experiencing homelessness for a year or longer and have an accompanying disability, such as physical or mental health conditions. The barriers keeping them in homelessness are extensive, making it challenging to effectively serve them in the emergency shelter setting, which typically allots only 30 days for case management and assistance. Due to this, many of these people continually cycle in and out of shelters and in and out of homelessness.

In Austin, Texas, Community First! Village serves the region's chronically homeless and is getting outstanding results. By providing dignified housing, onsite microenterprises that pay a dignified wage, vital community, and onsite mental health and recovery services, CFV has a stunning 88 percent retention rate, thus breaking the cycle of chronic homelessness for this difficult to house population.



In Pierce County, approximately 1100 people are chronically homeless. Pierce County and Tacoma Rescue Mission are seeking to create our own version of this model. The CFV Pierce County will be located in unincorporated Pierce County, on an 85.73 acre parcel off of Spanaway Loop Road, less than 5 miles from Lakewood. On 27 buildable acres, during Phase I of this project, we plan to construct 150 formerly homeless living units, 21 resident volunteer living units, 3 communal kitchens/multiuse spaces, 6 laundry/shower facilities, and 4 support buildings, including a village commons for large communal gatherings. Project duration of Phase I is November 2022 to Spring 2027, for an estimated total cost of \$49.4 million. All of the requested funding will be used in the 2023-24 timeframe.

CFV Pierce County will operate with three overarching rules for residents: be a good neighbor, comply with civil laws, and pay rent. There will be numerous onsite opportunities for microenterprises to empower residents and help them earn income. Both offsite and onsite volunteers will be key to this success, and can help with activities such as organic farming, cooking, tours, and events. Residents will also be supported by case management, mental healthcare services, and addiction recovery programs.

Tacoma Rescue Mission is submitting this grant application to the City of Lakewood with a request for \$2,000,000 toward Phase I of this project. Pierce County CFV will welcome, and plans to set aside, 25 microhomes for veterans. Attached is a letter from the VA offering 25 VASH vouchers for Pierce County CFV. Many of the chronically homeless are veterans. Currently 124 veterans are chronically homeless in Pierce County.

While this RFP may expect that the project be located within the City of Lakewood, CFV Pierce County will be located less than 5 miles from the City of Lakewood, and welcome chronically homeless from the City of Lakewood. This project represents a long-term investment for the City of Lakewood to help our vulnerable, chronically homeless neighbors, and we cannot successfully build and operate this unique village without the concerted efforts and support of all of Pierce County.

**Discuss and describe the community to be addressed through this project/program.**

**- Is your veteran emergency shelter/transitional housing project presumptively eligible under ARPA's Final Rule (see criteria above)?**

**Yes No**

**If yes, please describe how it is presumptively eligible (i.e., which criteria it follows from the ARPA Final Rule FAQs):**

As stated, CFV Pierce County will not be a shelter or transitional housing, but, respectfully, is just as an important use of Lakewood's resources as it will free up the capacity of existing shelter and transitional housing, and place chronically homeless, including veterans, in permanent supportive housing.

This project is presumptively eligible under ARPA's Final Rule because it is both an affordable housing development and provides permanent supportive housing. Residents will be served by trauma-informed staff members as they acclimate from experiencing homelessness to living in a stable, consistent environment. Dedicated case managers will assist these residents in creating and meeting goals, such as obtaining employment or enrolling in addiction recovery programs.

TRM works closely with other local providers to effectively serve our program participants. This philosophy will extend to CFV Pierce County. The CFV Pierce County project has received strong support from organizations such as Valeo Vocation, MultiCare, Associated Ministries, and Goodwill Industries. Letters of support can be provided at the City of Lakewood's request.

**- Is the community served a disproportionately impacted community under ARPA?**

People served by CFV Pierce County qualify as a disproportionately impacted community under ARPA. Since they are struggling with homelessness, they make well below Pierce County's 40 percent area median income. People experiencing homelessness have preexisting disabilities that resulted in more severe impacts from the COVID-19 pandemic. Already struggling with unemployment, lack of resources, and limited access to healthcare, the COVID-19 pandemic exacerbated these issues. As street outreach teams struggled to provide uninterrupted services during the pandemic, people experiencing homelessness then found it even more difficult to obtain basic essentials, such as food, water, blankets, and hygiene supplies.

**- How will this project or program address the community public health and/or negative economic impacts of COVID-19 (i.e., supporting the health of communities, and helping households, small businesses, impacted industries, nonprofits, and the public sector recover from economic impacts)?**

As discussed, the homeless and chronically homeless are already among the most vulnerable of communities, navigating disabling conditions, poverty, and the traumatic experiences that accompany losing housing. COVID-19 significantly impacted this population, exacerbating their struggles and creating new barriers. CFV Pierce County will help curtail the negative impacts of COVID-19 by providing affordable housing opportunities to people experiencing chronic homelessness. It will also provide support in the form of case management, assisting these individuals in obtaining social security and other benefits, employment, and education.

Additionally, by providing permanent supportive housing to people experiencing chronic homelessness, CFV Pierce County will also free up emergency shelter space to assist more people in our community. By helping both the homeless and chronically homeless to move off the streets — out of encampments and public rights of way — and into shelter and housing, CFV Pierce County will also benefit the greater community by decreasing costly emergency 911 dispatch calls, promoting healthier environments, encouraging tourism, and instilling pride in our neighborhoods.



**- Explain your organization’s experience and ability to implement, administer, and manage the proposed project/ program. How will success of this request be measured?**

Since 1912, Tacoma Rescue Mission has been serving people experiencing homelessness, including the chronically homeless. As time progresses, we adapt to serve the changing needs in our community. In 2010, we opened our family shelter, which now operates as the largest family shelter within Pierce County. Amidst the COVID-19 pandemic, we constructed and opened our first women’s shelter, doubling the available bed capacity for individual women experiencing homelessness in Pierce County. We have recently opened our kitchen to serve meals not just to shelter guests, but to anyone struggling with hunger who enters our doors. Currently, we operate two permanent supportive housing campuses — one for individuals and one for families.

Over the years, we have developed our service model to create the most positive outcomes for our program participants. Our service model is trauma informed, relationship driven, evidence based, diverse, and inclusive. We extend the grace and dignity that everyone deserves to all of the people we assist, regardless of their circumstance. These values uniquely position us to successfully manage CFV Pierce County. The goals are the same — to offer hope and healing to the most vulnerable of our neighbors, provide a permanent pathway out of poverty, and help them become their best selves.

Success of this request will be measured in completion of Phase I of the project. Our monetary request to the City of Lakewood will contribute to the capital needed to construct CFV Pierce County. Once constructed, we will measure success in obtaining residents and tracking retention rate, among other numbers.

## PROJECT BUDGET

**Provide a detailed itemized budget below to support amount requested later in this application. Also provide any relevant attachments.**

Phase 1A: Site Preparation, Initial Infrastructure, 50 Housing Units

Timing: November 2022 - Fall 2024

Estimated Cost: \$23.66 million

Scope:

- Land purchase
- Design, permitting
- Site clearing, prep, and fencing
- New road from entrance to West Village; bridge
- Utilities: power, water, septic
- East Village: 3-5 model units, Visitors Center (barn renovation), Tent (for gatherings)
- West Village
  - 50 Formerly Homeless (FH) living units
  - 7 resident volunteer units
  - 2 microunits for clinic/enterprises (later converted to FH housing)
  - 1 park model to serve temporarily as a mini-market (later convert to FH housing)
  - 2 laundry and shower facilities
  - 1 communal kitchen/multi-use space
  - Farm prep and dog park
  - 1 Temporary administrative building (portable)

Phase 1B: Extension of Utilities and Infrastructure, 50 Additional Units

Timing: January 2025 - December 2025

Estimated Cost: \$15.56 million

Scope (all West Village):

- Extension of road/utilities
- 50 FH living units
- 7 resident volunteers
- 2 microunits/clinic
- 2 laundry/shower
- 1 communal kitchen/gathering
- Village Commons (multi-use: gathering, clinical, case-management)

### Phase 1C: 50 Additional Units

Timing: Spring 2026 - Spring 2027

Estimated Cost: \$10.17 million

Scope (all West Village):

- 50 FH living units
- 7 resident volunteers
- 2 micro units for clinic/enterprises (convert later FH housing)
- 2 laundry and shower
- 1 communal kitchen/meeting

### Phase I Overview

150 formerly homeless living units

6 microunit clinics/markets

21 resident volunteer living units

3 communal kitchens/multi-use spaces

6 laundry/shower facilities

4 support buildings (including portables)

Period: November 2022 – Spring 2027

Total estimated cost: \$49.4 million



**DEPARTMENT OF VETERANS AFFAIRS**  
**Puget Sound Health Care System**  
**1660 South Columbian Way**  
**Seattle, WA 98108-1597**



American Lake Division  
Tacoma WA 98493-5000

In Reply Refer To: 663/S-SWS-211

Seattle Division  
Seattle WA 98108-1597

James W. Stretz, Executive Director  
Pierce County Housing Authority  
603 South Polk Street  
Tacoma, WA 98444

Dear James Stretz,

I am pleased to submit this letter of support on behalf of the Pierce County Housing Authority (PCHA) application to convert up to 25 HUD-VASH tenant-based vouchers to project-based vouchers for Pierce County's project currently called The Community First Village. The Community First Village is modeled after a successful permanent housing program in Austin, TX with the same name.

The Community First Village will have 250 microhomes to permanently house chronically homeless Veterans and non-Veterans through purposeful work, restorative relationship and vibrant community. Onsite mental health and substance use services, security, and employment support will be provided to residents, which will be provided by Tacoma Rescue Mission. Staff and volunteers will live alongside formerly homeless residents in 30 additional microhomes, with the goal to better foster a sense of community and belonging, which has been key in the Austin, TX model. Estimated completion of Pierce County's Community First Village is July 2023.

PCHA continues to be a fantastic HUD-VASH program partner, working hard with VA Puget Sound Health Care System and the larger community toward the goal of ending Veteran homelessness. The VA Puget Sound Health Care System is a strong supporter of and partner with PCHA. Given the large number of vulnerable chronically homeless Veterans in Pierce County, transitioning the tenant-based vouchers to project-based vouchers will allow for secured affordable, permanent supportive housing for Veterans, which will assist our collective effort to end Veteran homelessness. VA Puget Sound supports this voucher transition and looks forward to continued collaboration with your agency.

Should you have any questions about this letter, please contact Laura Rollins, Program Manager of Community Housing and Outreach Services (Pierce, Snohomish and Balance of State), VA Puget Sound, at 206-849-5467.

Sincerely,

Thomas S. Bundt, PhD, FACHE, Acting Director

CC: Tamara Meade, Director of Supportive Housing Programs, Pierce County Housing Authority.



**IRS** Department of the Treasury  
Internal Revenue Service

P.O. Box 2508, Room 4010  
Cincinnati OH 45201

In reply refer to: 4077550279  
Feb. 23, 2011 LTR 4168C 0  
91-0565014 000000 00

00042760  
BODC: TE

THE RESCUE MISSION  
PO BOX 1912  
TACOMA WA 98401-1912



025501

Employer Identification Number: 91-0565014  
Person to Contact: Sophia Brown  
Toll Free Telephone Number: 1-877-829-5500

Dear Taxpayer:

This is in response to your Nov. 08, 2010, request for information regarding your tax-exempt status.

Our records indicate that you were recognized as exempt under section 501(c)(3) of the Internal Revenue Code in a determination letter issued in May 1940.

Our records also indicate that you are not a private foundation within the meaning of section 509(a) of the Code because you are described in section(s) 509(a)(1) and 170(b)(1)(A)(vi).

Donors may deduct contributions to you as provided in section 170 of the Code. Bequests, legacies, devises, transfers, or gifts to you or for your use are deductible for Federal estate and gift tax purposes if they meet the applicable provisions of sections 2055, 2106, and 2522 of the Code.

Please refer to our website [www.irs.gov/eo](http://www.irs.gov/eo) for information regarding filing requirements. Specifically, section 6033(j) of the Code provides that failure to file an annual information return for three consecutive years results in revocation of tax-exempt status as of the filing due date of the third return for organizations required to file. We will publish a list of organizations whose tax-exempt status was revoked under section 6033(j) of the Code on our website beginning in early 2011.

RECEIVED

FEB 28 2011

SKH

4077550279  
Feb. 23, 2011 LTR 4168C 0  
91-0565014 000000 00  
00042761

THE RESCUE MISSION  
PO BOX 1912  
TACOMA WA 98401-1912

If you have any questions, please call us at the telephone number shown in the heading of this letter.

Sincerely yours,



Cindy Thomas  
Manager, EO Determinations





# City of Lakewood, WA

## American Rescue Plan Funding Application

### - **Permanently Affordable Housing** -

6000 Main St SW • Lakewood, WA 98499

Office Phone: (253) 983.7702 • Email: [tspeir@cityoflakewood.us](mailto:tspeir@cityoflakewood.us)

### Organization Information

Legal Name of Organization:

LASA

---

Doing Business As: Living Access Support  
Alliance

---

Address: 8956 Gravelly Lake Dr SW

City: Lakewood \_\_\_\_\_ Zip: 98499 \_\_\_\_\_

Website: [www.LASApierce.org](http://www.LASApierce.org)

Year of Formation: 1989

|                 | CEO/Executive Director          | Project Coordinator (if different) |
|-----------------|---------------------------------|------------------------------------|
| Name            | Janne Hutchins                  |                                    |
| Title           | Executive Director              |                                    |
| Email Address   | Janne@lasawa.org                |                                    |
| Phone Number    | 253-581-8689                    |                                    |
| Mailing Address | PO Box 98619 Lakewood, WA 98498 |                                    |

Taxpayer Identification Number: 91-1470619

UEI Number (Required\*): E1ATKUQ1AEP8

\*UEI Number can be obtained [here](#).

Is your Entity registered with SAM.gov (Required)? Yes X \_\_\_\_\_ No \_\_\_\_\_

If a nonprofit, have you attached a current nonprofit 501(c)(3) tax exempt status, as confirmed by IRS?: Yes X \_\_\_\_\_ No \_\_\_\_\_

I certify that I have the legal authority of the organization represented in this application to submit this request for funding on its behalf, and I further certify that the information submitted in this application is true and correct to the best of my knowledge. I understand that the City of Lakewood will rely on the accuracy of the submittals and certifications made in conjunction with this application. Any misrepresentation of inaccurate information or unused ARPA funds may result in a repayment of funds. If awarded, my organization intends to enter into a contract with the City of Lakewood, provide liability insurance as may be required for the duration of the contract naming the City of Lakewood as an additional insured and in an amount determined by the City.

Janne Hutchins

SIGNATURE

10.10.22

DATE

Janne Hutchins Executive Director

Print Name and Title

|                        | <b>CEO/Executive Director</b>   | <b>Project Coordinator (if different)</b> |
|------------------------|---------------------------------|---|
| <b>Name</b>            | Janne Hutchins                  |   |
| <b>Title</b>           | Executive Director              |   |
| <b>Email Address</b>   | Janne@lasawa.org                |   |
| <b>Phone Number</b>    | 253-581-8689                    |   |
| <b>Mailing Address</b> | PO Box 98619 Lakewood, WA 98498 |   |

**Taxpayer Identification Number:** 91-1470619

**UEI Number (Required\*):** E1ATKUQ1AEP8

\*UEI Number can be obtained [here](#).

**Is your Entity registered with [SAM.gov](#) (Required)?** Yes X \_\_\_\_\_ No \_\_\_\_\_

**If a nonprofit, have you attached a current nonprofit 501(c)(3) tax exempt status, as confirmed by IRS?:** Yes X \_\_\_\_\_ No \_\_\_\_\_

I certify that I have the legal authority of the organization represented in this application to submit this request for funding on its behalf, and I further certify that the information submitted in this application is true and correct to the best of my knowledge. I understand that the City of Lakewood will rely on the accuracy of the submittals and certifications made in conjunction with this application. Any misrepresentation of inaccurate information or unused ARPA funds may result in a repayment of funds. If awarded, my organization intends to enter into a contract with the City of Lakewood, provide liability insurance as may be required for the duration of the contract naming the City of Lakewood as an additional insured and in an amount determined by the City.

                     **Authorized signature attached**

\_\_\_\_\_  
**SIGNATURE**

\_\_\_\_\_  
**DATE**

\_\_\_\_\_  
**Print Name and Title**



**Project Information**

**Please attach additional pages as needed.**

**Project Name: Gravelly Lake Commons** \_\_\_\_\_

**Total Project/Program Cost: \$11,412,469.00** \_\_\_\_\_

**Amount of ARPA Funds Requested\*: \$3,500,000.00** \_\_\_\_\_

\*Include detailed itemized budget to support amount requested later in this application. Provide any relevant attachments.

**Annual Project/Program Cost to be funded with ARPA Funds (if different than amount above):**  
\_\_\_\_\_

**Have you received other COVID-19 Relief Funding\* related to this project/program?**

Yes x \_\_\_ No \_\_\_

\*(e.g., funds from ARPA, CARES Act, other nonprofits, or government)

**If Yes, please provide details on funding: Pierce County has pledged \$3.5 million to this project form their ARPA funding. Pierce County will release this portion when all capital funds have been raised. We hope to obtain partial funding from this application in advance to cover predevelopment costs in the amount \$1.5Million**  
\_\_\_\_\_

**Estimated Project/Program Schedule:**

**Start Date: Spring 2023 (Please See attached Project Timeline)** \_\_\_\_\_

**End Date\*: November 30,2026** \_\_\_\_\_

\*Per the act, ARPA funds must be fully expended by 12/31/26. **This project’s contract may require that its specific funds be fully expended by an earlier date.**

Gravelly Lake Commons will be situated at the corners of Gravelly Lake Dr SW, 59<sup>th</sup> Street and Fairlawn Drive in Lakewood. The entire complex will feature 55 one-, two- and three-bedroom apartments targeted for the 30 to 50% AMI income bracket. The complex will also be home to an affordable day care facility.

Gravelly Lake Commons will be ideally situated on a bus line next to LASA’s Client Services Center and within walking distance to a skate park, school, services and shopping.

In order to bring critically needed housing to market as quickly as possible, we have broken the project into two stages. The first will provide 25 units of housing which this application is requesting support for.

With over thirty years of experience working with families experiencing homelessness and households at risk of losing their housing, we have the experience to configure the number and size of units to meet the needs of our community. This Phase should be completed by the Fall of 2026.

**Discuss and describe the community to be addressed through this project/program.**

- **Is your affordable housing project presumptively eligible under ARPA’s Final Rule (see**

criteria above)?

Yes  No

If yes, please describe how it is presumptively eligible (i.e., which criteria it follows from the ARPA Final Rule FAQs

***Assistance to households – Impacted Households and Communities***

- Programs or services to support long term housing security: including development of affordable housing and permanent supportive housing

***Disproportionately Impacted Households & Communities***

- Improvements to vacant and abandoned properties, including rehabilitation or maintenance, renovation, removal and remediation of environmental contaminants, demolition or destruction, greening/vacant lot cleanup and conversion to affordable housing

***Capital Expenditures***

- LASA is constructing a campus in central Lakewood dedicated to the provision of housing and services created to help residents maintain their housing. (Ancillary services will also be offered) This is in keeping with our mission: to prevent homelessness and recurrent homelessness. To achieve the goal of providing a service enriched housing environment, we broke the development into four phases and this application is in support of Phase 3:
- Phase 1: Build a Client Services Center (CSC) along with fifteen units of housing, (Completed)
- Phase 2: Add Hygiene Center/multipurpose room; Permit ready with committed funds. (Building Starts Fall 2022) This phase is in process.
- Phase 3: Design and construct twenty-five units of affordable housing; re-zoning has been applied for and is in process, preliminary architectural drawings completed. The project is actively pursuing funding. Awarded \$3.5M By Pierce County, application submitted to Department of Commerce Washington State, Housing Trust Fund (application pending)
- Phase 4: Add additional twenty-five units along with a Low-Cost Daycare Center.

**Steps to completing Phase 3:**

- The most difficult task, acquiring appropriate land has been completed.
- Create budget and Secure funds
- two houses demolished, two families relocated,
- an architect, engineer and builder hired (James Guerrero, a highly respected and local architect has been working with us in initial planning). We have met with Edge Developers, the Planning Department at the city of Lakewood, and other development team members.

Local architect, James Guerrero, put plans on paper showing the preliminary housing design. The Project includes four walk-up buildings encompassing 1, 2, and 3 bedrooms. The wood framed structure will include private decks for each unit, a central laundry facility, children's play area, and a 25-space surface parking lot. We will incorporate green features such as energy efficient appliances and fixtures, water saving methods, efficient building practices, and seek solar panel funds from the same source who has preliminary committed funding for Flett Meadows. The initial budget has been prepared, which will be refined once funds are secured, and architectural plans further developed.

**Is the community served a disproportionately impacted community under ARPA?** Yes, the population that will be served will be low-income households, we anticipate most to be receiving federal benefits.

**How will this project or program address the community public health and/or negative economic impacts of COVID-19 (i.e., supporting the health of communities, and helping households, small businesses, impacted industries, nonprofits, and the public sector recover from economic impacts)?** Housing directly impacts your health and your success in life. It is one of the social, economic, and environmental conditions that produces 55% of health: Those who live in poor housing conditions or are unhoused are at higher risk for high blood pressure, asthma, respiratory infections, behavioral health issues, and other chronic conditions. Teens who do not have stable housing are half as likely to graduate from high school. During the COVID-19 pandemic, those who live in crowded, multi-generational households or poor-quality housing are more likely to get sick. Without stable housing, people must rely on friends, family, or co-workers for temporary housing; others sleep in shelters, the streets, or in their cars. That makes it hard for children to do homework and adults to keep or find a job. People also lose treasured mementos, social connections, medications, and important documents needed for school, jobs, financial transactions, and benefits. In addition, where you live, work, learn, and play determines how healthy you are and how long you live:

Residents in various parts of Pierce County may have a 20-year gap in life expectancy. Areas with longer life expectancy and less disease also have higher levels of education and income. People who live in rural areas tend to be older and sicker than urban residents and are more likely to die from heart disease, cancer, unintentional injury, chronic lung disease, and stroke. Unfortunately, there are racial and ethnic differences with our Black, Indigenous, and Pacific Islander families suffering more from housing instability and homelessness. (Chen, Anthony. "Housing is essential for good health." *TPCHD.org*, Tacoma Pierce County Health Department, 29 Nov. 2021. [www.tpchd.org/Home/Components/Blog/Blog/32295](http://www.tpchd.org/Home/Components/Blog/Blog/32295)

In response to the information listed LASA will develop and build Gravelly Lake Commons (GLC). GLC offers permanent housing to low-income households. Eligibility requires the household be a Pierce County resident and in the 30 to 50% AMI range. Tenancy will be open to populations who may or may not have come from the following populations: DV (Domestic Violence), Veterans, new to sobriety and/or have health, or mental health issues All the units will be set aside for households at 50% or less AMI, with six set aside for those at 30%.

**Explain your organization's experience and ability to implement, administer, and manage the proposed project/ program. How will success of this request be measured?** LASA developed Prairie Oaks in partnership with the Tacoma Housing Authority and Pierce County Housing Authority six years ago and even then, with a more stable construction environment, we had to practice Value Engineering (VE) several times to meet our budget. Example: this included compromising with irrigation. As the nonprofit host of the site, we agreed to water the property ourselves for the first two years until vegetation could be established. While we lost some plants, in general the landscaping thrived. Now we have raised sufficient funds to add irrigation; another example of VE was when we researched materials that could be substituted with less costly materials.



At this time LASA is developing a Hygiene Center along with a multipurpose room that can be used as a Warming and Cooling Center. Our original plans called for the addition of a Commercial kitchen which had to be dropped from the budget.

When conducting a major rehab at a 14-unit complex known as Flett Meadows, we ran into the perfect storm of rising prices (due to Hurricane Sandy) from the time the budget was designed until we received funding. We were clearly going to be short of funds to complete everything in the scope. We prioritized our needs and completed the work on the envelope of all the building and postponed the interior work which we have been tackling unit by unit.

**PROJECT BUDGET** Provide a detailed itemized budget below to support amount requested later in this application. Also provide any relevant attachments.

**Please see attached detailed budget.**

3. Capital Expenditures: For projects reported under the Project Expenditure Categories EC1: Public Health, EC2: Negative Economic Impact and EC3: Public Health- Negative Economic impact: Public Sector Capacity, provide answers to the following Questions (refer to Figure IV – 19):

- Does the project include capital expenditure, including predevelopment cost, if applicable?  
**Answer: Yes**
- If “Yes”:
  - What is the total expected cost of the capital expenditure, including predevelopment costs, if applicable?  
**Answer: \$11,412,469.00**
  - Type of capital expenditure, bases on the following enumerated uses (as noted in Appendix H)  
**Answer: Affordable Housing, Supportive Housing or Recovery housing development**
- ❖ All other answers in this Field are **Not applicable** to this application as our ask is less than \$10Million.



TO: Mayor, Deputy Mayor, and City Councilmembers

FROM: Michael Vargas, Assistant to the City Manager/Policy Analyst

THROUGH: John Caulfield, City Manager  
Tho Kraus, Deputy City Manager/CFO *John E. Caulfield*

DATE: November 28, 2022

SUBJECT: Lakewood Library System Fiscal Analysis

### **Executive Summary**

The City Council, as part of their August 1, 2022 regular meeting asked for financial information specific to library services provided by the Pierce County Library System (PCLS) in Lakewood.

The attached fiscal analysis for 2019 through 2023 illustrates revenue sources generated by the PCLS in Lakewood, which includes property tax revenues levied specifically for library services and other revenue sources compared to the cost of providing library services at two library locations, the Lakewood Main downtown library and Tillicum library by the PCLS.

This fiscal analysis is focused on operating revenues and operating expenditures. The current status of the two PCLS library facilities in Lakewood and recommendations specific to capital needs for new libraries in Lakewood were prepared by the Library Advisory Committee and presented at a joint meeting of the City Council and PCLS Board of trustees on November 17, 2022.

The key findings are as follows:

- The two libraries operated by the PCLS in Lakewood operate at a net operating loss (Graph 1), meaning PCLS does not generate enough revenue from Lakewood to fully finance annual operating expenditures in support of these two libraries. Operating expenditures are exceeding operating revenues, which also means that overall library system is financially subsidizing the delivery of library services by the PCLS in Lakewood.
- The revenue generated specific to Lakewood and system wide is not sufficient to finance either new libraries or major capital improvements to the existing Lakewood libraries, which is the reason that PCLS will need to pursue a capital bond initiative that will need to be considered by Lakewood voters.
- The reduced operating margin in 2023 takes into account that PCLS will be operating out of an interim downtown library facility, though the larger negative operating loss will return once PCLS identifies a new permanent library facility in the downtown.

**Graph 1: Lakewood Library System Operating Revenue & Operating Expenditures**

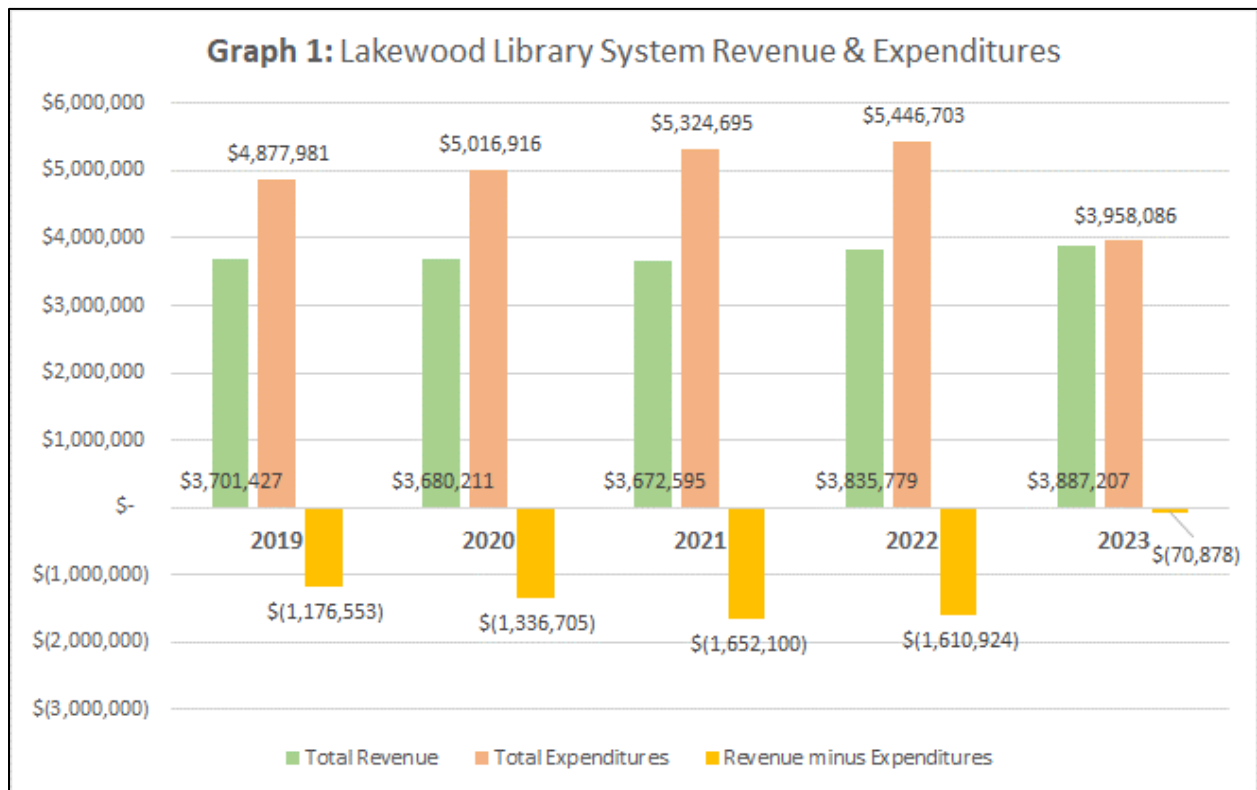



- In terms of efficiency, PCLS achieves a lower and more efficient operating cost-per-capita system-wide (\$57) compared to the two libraries located in Lakewood (\$77) due to its economies of scale, while these two libraries have the highest operating cost-per-capita compared to PCLS and other municipal library systems (Graph 2).

**Graph 2: 2019 Operating Expenditures & Operating Expenditure-per-Capita**

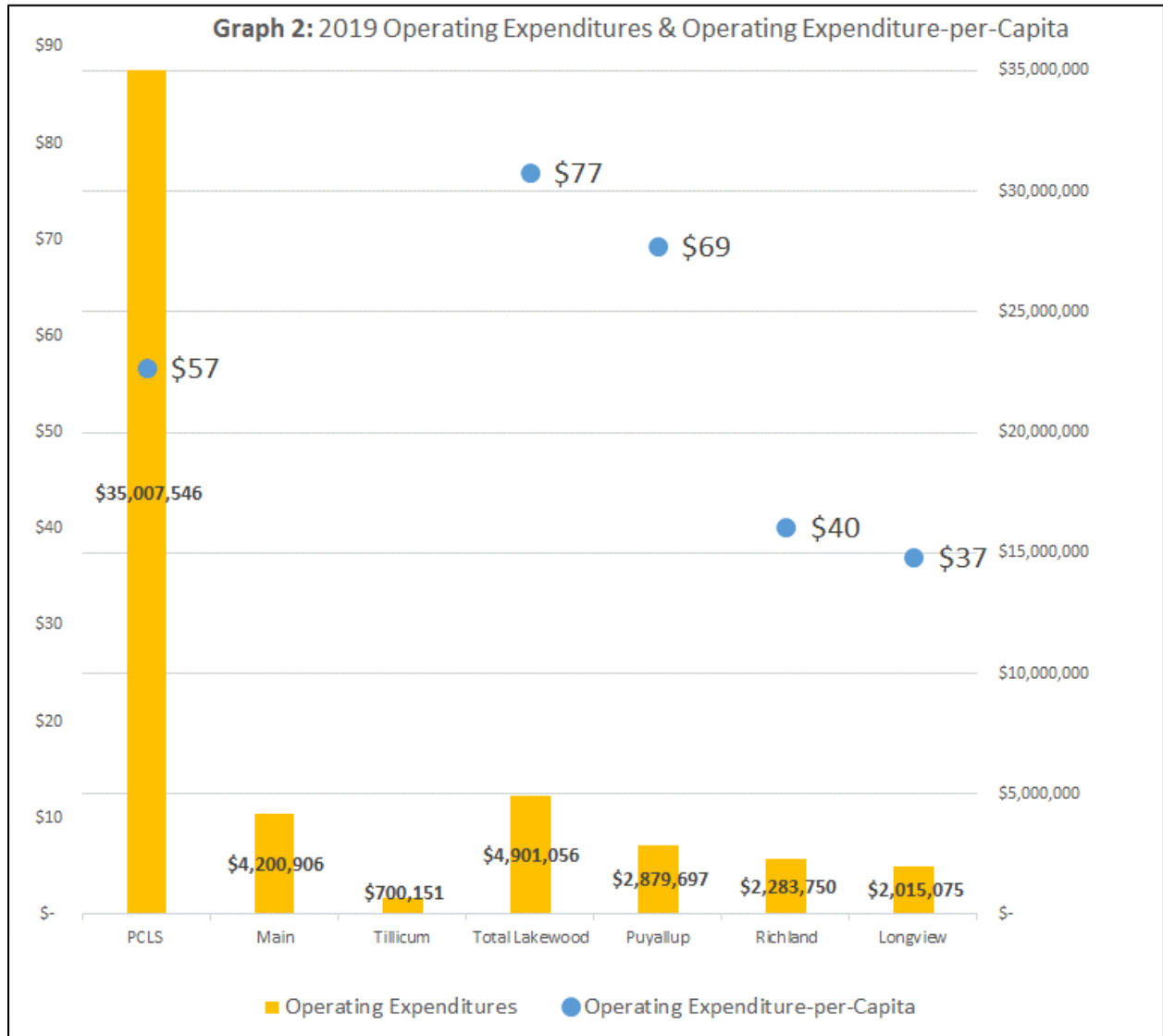

- Based on this fiscal analysis, it is unlikely the City would be able to provide library services at a level equal to or greater than the services and events provided by the PCLS. The City would need to subsidize library operations from the City’s General Fund, which would have a negative impact on other city services. And this subsidy would only grow over time since property taxes are limited to an annual growth of 1%, while annual operating expenditures would grow at a much higher rate, especially in today’s environment with inflation at a level not seen in over 40 years. The City would also need to account for additional costs in areas

such finance and information technology, human resources, and property management since it is very unlikely these costs could be absorbed into existing City operations.

- The City would also be responsible for new library facilities based on the outcome of the work and recommendations from the Library Advisory Committee (LAC). This includes undertaking a capital bond proposition that will require 60% voter approval.
- These conclusions are not surprising since most cities and towns in the Puget Sound region are part of a regional library services district (e.g., Pierce County Library System, King County Library System and Sno-Isle Libraries).

## **Library District System Advantages**

The following benefits of the PCLS emphasize the positive impacts of an interconnected library system, economies of scale, and library tax districts:

- **Interconnected Library System**
  - Users have access to library materials from the entire service area, representing diverse interests across many Pierce County communities.
  - Users are able to order materials from other locations and have it delivered to their local branch.
  - Users can visit any PCLS library and expect the same quality and consistency of services, as well as attend PCLS programs.
  - Purchasing and processing of library materials by dedicated experts are centralized and shared across the whole system, saving physical room at libraries.
- **Economies of Scale**
  - Large scale events that serve communities across Pierce County, including Lakewood, such as PCLS Summer Reading, are possible with a large, dedicated resource pool provided by a regional library system.
  - A system has more purchasing power as it buys books and materials in higher volumes and spends considerably more on materials than a small, standalone library, maximizing impact-per-dollar.
  - Databases and information resources benefit from the large purchasing power of a system.
- **Library Taxing District**
  - A library system as a taxing district focuses solely on providing library services, whereas a municipal library, as a city department, competes for funding among other departments.
  - Taxing districts have the benefit of stability and predictability regarding operating revenues.
  - A large, dedicated revenue stream as a system allows the targeting of improvements, investments, and services.

## Lakewood Main Downtown Library Branch Profile

The Lakewood Main Downtown Library Branch consisted of 28.8 full-time equivalent positions in 2019. Positions included the Branch Manager, Supervising Librarian, Supervising Associate, Librarians, Customer Experience Specialists, Customer Experience Assistants, Clerks and Custodians. Additionally, the library received regular assistance and support from other PCLS departments such as human resources, information technology, finance, and facilities.

Branch staffing in 2023 is proposed to be 14.6 full-time equivalent positions given PCLS will be operating out of an interim library facility. Full staffing to include full operating expenditures will return to 2019 to 2022 levels once a new permanent library facility is identified in the downtown.

The following presents data about the Lakewood Main downtown library in the areas of foot traffic, events and programs, monthly circulation, and computer sessions for 2019, which was the last full pre-pandemic year.

### 2019 Foot Traffic

- Prior to the adjustments made to service in response to the pandemic, this library was open 63 hours per week. A total of 261,884 people visited the library in 2019, circulating 438,315 items.
- The library planned and implemented 361 programs in 2019 with 8,414 people in attendance.
- Since the Lakewood Main downtown library branch closure, PCLS has continued to connect with community members. In 2022, this branch has offered services at more than 200 programs, pop-up library events, and outreach opportunities from early June through the end of October.

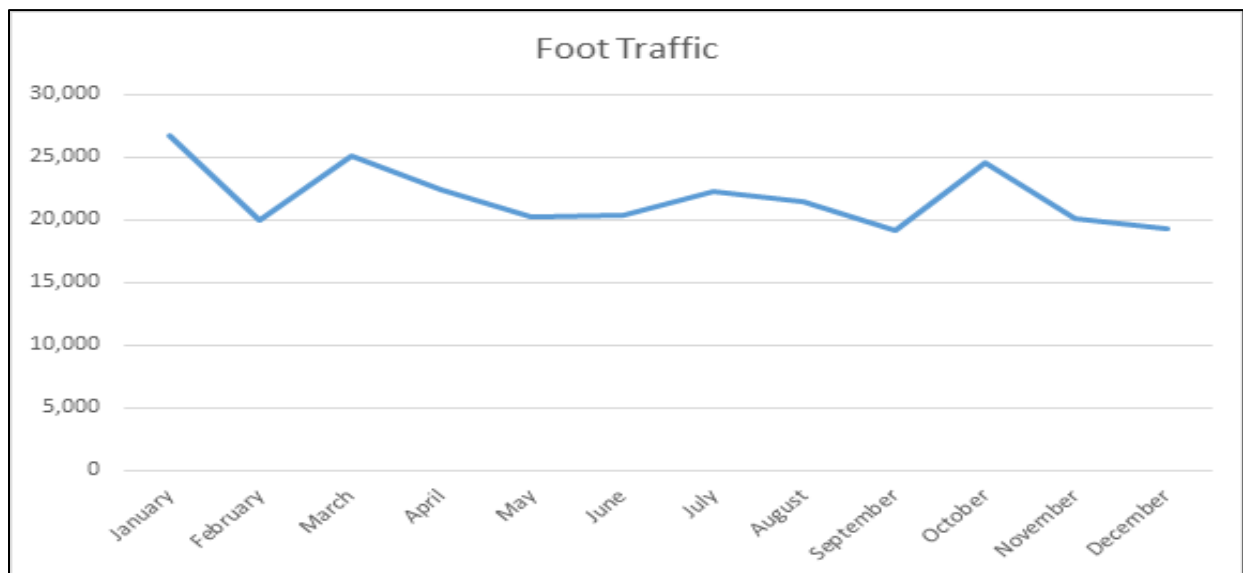

2019 Monthly Circulation

- Prior to the closure of the Lakewood Pierce County Library, the collection size in the branch was 65,862 items with Lakewood cardholders having access to the entire PCLS collection containing 669,570 physical items.

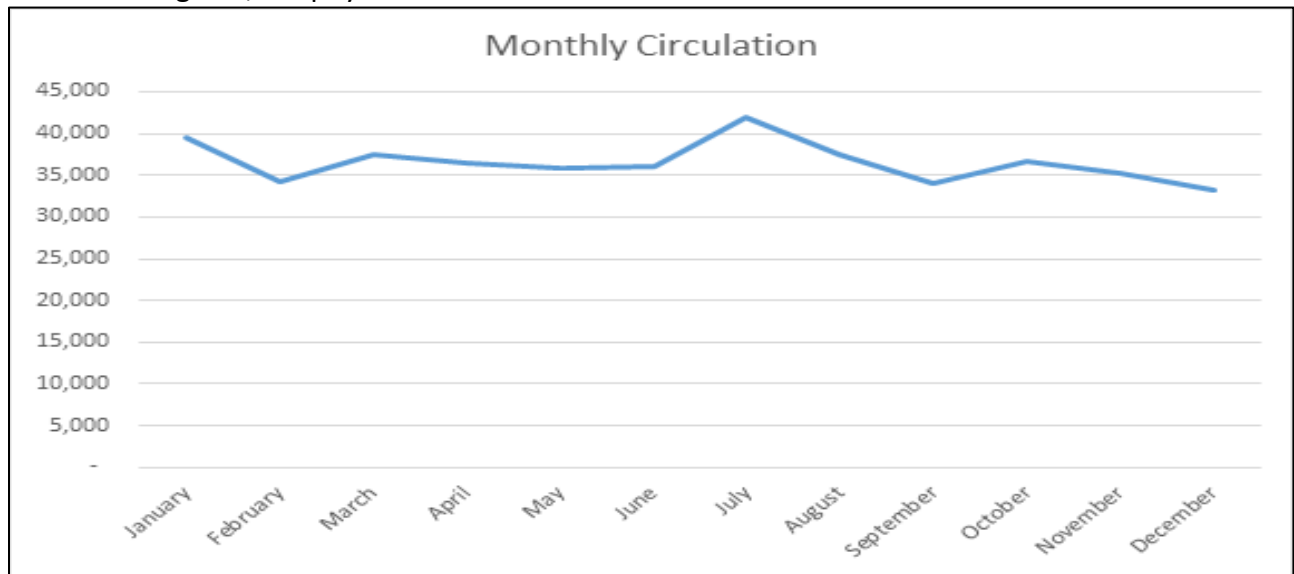

2022 Computer Sessions prior to closure

- The Lakewood Main Downtown Library Branch had 51 computers for public use and public printing, scanning, faxing, and copying services. This graph shows the number of sessions each month for public computer use prior to the closure on June 5, 2022.

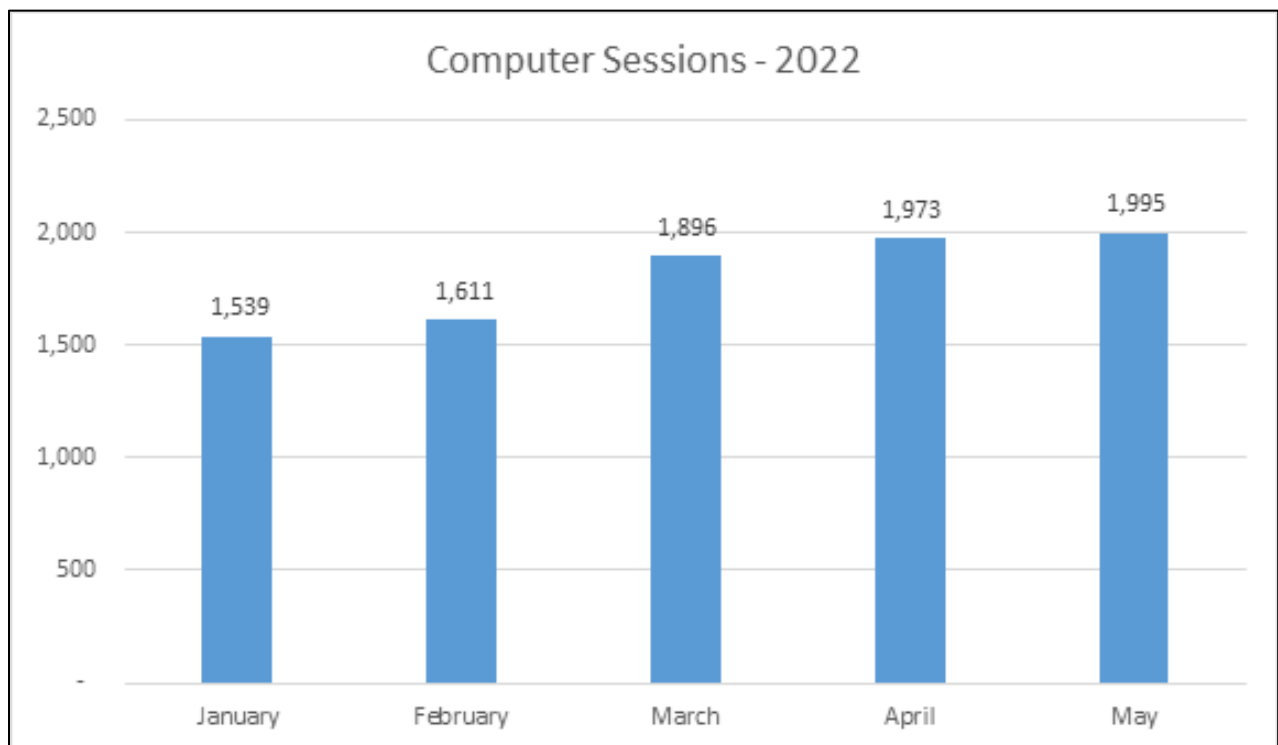



## **Conclusion**

In summary, based on the key findings above, it is unlikely the City would be able to provide library services at a level equal to or greater than the services and events provided by the PCLS.

### Attachments:

- Lakewood Library Financial Analysis (2019 to 2023)
- Lakewood Library Property Tax Levy Information (2019 to 2023)
- PCLS Personnel FTE Inventory (2019 to 2023)
- Comparative Workload Indicators for 2019

### Lakewood Library Fiscal Analysis

| Revenue                               | 2019 - Actual        |                     |                     |                       | 2020 - Actual        |                     |                     |                       | 2021 - Budget        |                     |                     |                       | 2022 - Budget        |                     |                     |                       | 2023 - Budget        |                     |                     |                     |
|---------------------------------------|----------------------|---------------------|---------------------|-----------------------|----------------------|---------------------|---------------------|-----------------------|----------------------|---------------------|---------------------|-----------------------|----------------------|---------------------|---------------------|-----------------------|----------------------|---------------------|---------------------|---------------------|
|                                       | PCLS                 | Main                | Tillicum            | Total Lakewood        | PCLS                 | Main                | Tillicum            | Total Lakewood        | PCLS                 | Main                | Tillicum            | Total Lakewood        | PCLS                 | Main                | Tillicum            | Total Lakewood        | PCLS                 | Main                | Tillicum            | Total Lakewood      |
| Taxes                                 | \$ 33,920,510        | \$ 3,464,873        | \$ -                | \$ 3,464,873          | \$ 37,740,474        | \$ 3,515,864        | \$ -                | \$ 3,515,864          | \$ 38,923,400        | \$ 3,538,105        | \$ -                | \$ 3,538,105          | \$ 41,522,400        | \$ 3,675,549        | \$ -                | \$ 3,675,549          | \$ 44,490,000        | \$ 3,661,317        | \$ -                | \$ 3,661,317        |
| Intergovernmental                     | \$ 96,021            | \$ 11,523           | \$ 1,920            | \$ 13,443             | \$ 33,884            | \$ 4,066            | \$ 678              | \$ 4,744              | \$ 15,000            | \$ 1,800            | \$ 300              | \$ 2,100              | \$ 15,000            | \$ 1,800            | \$ 300              | \$ 2,100              | \$ 15,000            | \$ 1,800            | \$ 300              | \$ 2,100            |
| Charges for Services                  | \$ 531,689           | \$ 63,803           | \$ 10,634           | \$ 74,436             | \$ 41,150            | \$ 4,938            | \$ 823              | \$ 5,761              | \$ 7,500             | \$ 900              | \$ 150              | \$ 1,050              | \$ 17,500            | \$ 2,100            | \$ 350              | \$ 2,450              | \$ 17,500            | \$ 2,100            | \$ 350              | \$ 2,450            |
| Fines                                 | \$ 182,338           | \$ 21,881           | \$ 3,647            | \$ 25,527             | \$ 38,559            | \$ 4,627            | \$ 771              | \$ 5,398              | \$ 10,000            | \$ 1,200            | \$ 200              | \$ 1,400              | \$ 10,000            | \$ 1,200            | \$ 200              | \$ 1,400              | \$ 10,000            | \$ 1,200            | \$ 200              | \$ 1,400            |
| Donors                                | \$ 349,220           | \$ 41,906           | \$ 6,984            | \$ 48,891             | \$ 306,712           | \$ 36,805           | \$ 6,114            | \$ 42,940             | \$ 275,000           | \$ 33,000           | \$ 5,500            | \$ 38,500             | \$ 300,000           | \$ 36,000           | \$ 6,000            | \$ 42,000             | \$ 300,000           | \$ 36,000           | \$ 6,000            | \$ 42,000           |
| Other                                 | \$ 530,409           | \$ 63,649           | \$ 10,608           | \$ 74,257             | \$ 753,596           | \$ 90,432           | \$ 15,072           | \$ 105,503            | \$ 762,000           | \$ 91,440           | \$ 15,240           | \$ 106,680            | \$ 802,000           | \$ 96,240           | \$ 16,040           | \$ 112,280            | \$ 1,271,000         | \$ 152,520          | \$ 25,420           | \$ 177,940          |
| <b>Total Revenues</b>                 | <b>\$ 35,610,187</b> | <b>\$ 3,667,634</b> | <b>\$ 33,794</b>    | <b>\$ 3,701,427</b>   | <b>\$ 38,914,375</b> | <b>\$ 3,656,733</b> | <b>\$ 23,478</b>    | <b>\$ 3,680,211</b>   | <b>\$ 39,992,900</b> | <b>\$ 3,666,445</b> | <b>\$ 6,150</b>     | <b>\$ 3,672,595</b>   | <b>\$ 42,666,900</b> | <b>\$ 3,812,889</b> | <b>\$ 22,890</b>    | <b>\$ 3,835,779</b>   | <b>\$ 46,103,500</b> | <b>\$ 3,854,937</b> | <b>\$ 32,270</b>    | <b>\$ 3,887,207</b> |
| <b>Expenditures</b>                   |                      |                     |                     |                       |                      |                     |                     |                       |                      |                     |                     |                       |                      |                     |                     |                       |                      |                     |                     |                     |
| Personnel with benefits               | \$ 23,731,958        | \$ 3,154,504        | \$ 601,370          | \$ 3,755,874          | \$ 25,006,372        | \$ 3,154,504        | \$ 535,645          | \$ 3,690,150          | \$ 27,623,800        | \$ 3,188,014        | \$ 541,507          | \$ 3,729,521          | \$ 28,919,400        | \$ 3,271,061        | \$ 557,088          | \$ 3,828,149          | \$ 31,074,977        | \$ 2,037,635        | \$ 619,777          | \$ 2,657,412        |
| Maintenance & Operations, pro-rated   | \$ 4,589,431         | \$ 550,732          | \$ 91,789           | \$ 642,520            | \$ 5,677,652         | \$ 681,318          | \$ 113,553          | \$ 794,871            | \$ 6,811,900         | \$ 817,428          | \$ 136,238          | \$ 953,666            | \$ 7,253,600         | \$ 870,432          | \$ 145,072          | \$ 1,015,504          | \$ 8,421,238         | \$ 673,699          | \$ 168,425          | \$ 842,124          |
| Materials pro-rated                   | \$ 3,425,618         | \$ 411,074          | \$ 68,512           | \$ 479,587            | \$ 3,799,249         | \$ 455,910          | \$ 75,985           | \$ 531,895            | \$ 4,582,200         | \$ 549,864          | \$ 91,644           | \$ 641,508            | \$ 4,307,500         | \$ 516,900          | \$ 86,150           | \$ 603,050            | \$ 4,585,500         | \$ 366,840          | \$ 91,710           | \$ 458,550          |
| Subtotal                              | \$ 31,747,007        | \$ 4,116,310        | \$ 761,671          | \$ 4,877,981          | \$ 34,483,273        | \$ 4,291,732        | \$ 725,183          | \$ 5,016,916          | \$ 39,017,900        | \$ 4,555,306        | \$ 769,389          | \$ 5,324,695          | \$ 40,480,500        | \$ 4,658,393        | \$ 788,310          | \$ 5,446,703          | \$ 44,081,715        | \$ 3,078,174        | \$ 879,911          | \$ 3,958,086        |
| Transfers to Capital Improvement Fund | \$ 1,460,000         | \$ -                | \$ -                | \$ -                  | \$ 1,950,000         | \$ -                | \$ -                | \$ -                  | \$ -                 | \$ -                | \$ -                | \$ -                  | \$ 1,100,000         | \$ -                | \$ -                | \$ -                  | \$ -                 | \$ -                | \$ -                | \$ -                |
| Transfers to Special Revenue Funds    | \$ 1,100,000         | \$ -                | \$ -                | \$ -                  | \$ 1,780,000         | \$ -                | \$ -                | \$ -                  | \$ 380,000           | \$ -                | \$ -                | \$ -                  | \$ 1,173,000         | \$ -                | \$ -                | \$ -                  | \$ -                 | \$ -                | \$ -                | \$ -                |
| Set Aside for Apr/Oct Cash flow       | \$ -                 | \$ -                | \$ -                | \$ -                  | \$ -                 | \$ -                | \$ -                | \$ -                  | \$ -                 | \$ -                | \$ -                | \$ -                  | \$ -                 | \$ -                | \$ -                | \$ -                  | \$ -                 | \$ -                | \$ -                | \$ -                |
| Subtotal                              | \$ 2,560,000         | \$ -                | \$ -                | \$ -                  | \$ 3,730,000         | \$ -                | \$ -                | \$ -                  | \$ 380,000           | \$ -                | \$ -                | \$ -                  | \$ 2,273,000         | \$ -                | \$ -                | \$ -                  | \$ -                 | \$ -                | \$ -                | \$ -                |
| <b>Total Expenditures</b>             | <b>\$ 34,307,007</b> | <b>\$ 4,116,310</b> | <b>\$ 761,671</b>   | <b>\$ 4,877,981</b>   | <b>\$ 38,213,273</b> | <b>\$ 4,291,732</b> | <b>\$ 725,183</b>   | <b>\$ 5,016,916</b>   | <b>\$ 39,397,900</b> | <b>\$ 4,555,306</b> | <b>\$ 769,389</b>   | <b>\$ 5,324,695</b>   | <b>\$ 42,753,500</b> | <b>\$ 4,658,393</b> | <b>\$ 788,310</b>   | <b>\$ 5,446,703</b>   | <b>\$ 44,081,715</b> | <b>\$ 3,078,174</b> | <b>\$ 879,911</b>   | <b>\$ 3,958,086</b> |
| <b>Revenues less Expenditures</b>     | <b>\$ 1,303,180</b>  | <b>\$ (448,676)</b> | <b>\$ (727,877)</b> | <b>\$ (1,176,553)</b> | <b>\$ 701,102</b>    | <b>\$ (635,000)</b> | <b>\$ (701,705)</b> | <b>\$ (1,336,705)</b> | <b>\$ 595,000</b>    | <b>\$ (888,861)</b> | <b>\$ (763,239)</b> | <b>\$ (1,652,100)</b> | <b>\$ (86,600)</b>   | <b>\$ (845,504)</b> | <b>\$ (765,420)</b> | <b>\$ (1,610,924)</b> | <b>\$ 2,021,785</b>  | <b>\$ 776,763</b>   | <b>\$ (847,641)</b> | <b>\$ (70,878)</b>  |
| <b>Fund Balance</b>                   |                      |                     |                     |                       |                      |                     |                     |                       |                      |                     |                     |                       |                      |                     |                     |                       |                      |                     |                     |                     |
| Beginning Fund Balance                | \$ 7,738,394         | \$ -                | \$ -                | \$ -                  | \$ 9,042,172         | \$ -                | \$ -                | \$ -                  | \$ 9,743,274         | \$ -                | \$ -                | \$ -                  | \$ 10,500,000        | \$ -                | \$ -                | \$ -                  | \$ -                 | \$ -                | \$ -                | \$ -                |
| Ending Fund Balance                   | \$ 9,042,172         | \$ -                | \$ -                | \$ -                  | \$ 9,743,274         | \$ -                | \$ -                | \$ -                  | \$ 10,500,000        | \$ -                | \$ -                | \$ -                  | \$ 10,500,000        | \$ -                | \$ -                | \$ -                  | \$ -                 | \$ -                | \$ -                | \$ -                |

Taxes for Main and Tillicum are the property tax revenue collected in Lakewood  
Other revenues include interest earned on investments, scrap sales of assets and Friends of the Library donations.

**Low Information**

| Library                 | 2019             | 2020             | 2021             | 2022             | 2023 Prelim       |
|-------------------------|------------------|------------------|------------------|------------------|-------------------|
| Lakewood Assessed Value | \$ 6,929,745,386 | \$ 7,456,764,386 | \$ 8,111,198,629 | \$ 9,388,375,496 | \$ 10,968,596,101 |
| Library Levy Rate       | \$ 0.50          | \$ 0.47          | \$ 0.44          | \$ 0.39          | \$ 0.33           |
| Property Tax Revenue    | \$ 3,464,873     | \$ 3,515,864     | \$ 3,538,105     | \$ 3,675,549     | \$ 3,661,317      |

**Personnel FTE Inventory**

| Position Title                          | Branch   | 2019       |      |             |            | 2020           |            |            |             | 2021       |                |            |      | 2022        |            |                |             | 2023       |             |            |                |
|---|----------|------------|------|-------------|------------|----------------|------------|------------|-------------|------------|----------------|------------|------|-------------|------------|----------------|-------------|------------|-------------|------------|----------------|
|   |          | Total FTEs | PCLS | Main        | Tillicum   | Total Lakewood | Total FTEs | PCLS       | Main        | Tillicum   | Total Lakewood | Total FTEs | PCLS | Main        | Tillicum   | Total Lakewood | Total FTEs* | PCLS       | Main*       | Tillicum   | Total Lakewood |
| Branch Manager                          | Main     | 1.0        | -    | \$ 124,684  | -          | \$ -           | 1.0        | -          | \$ 124,684  | 1.0        | -              | \$ 126,243 | 1.0  | -           | \$ 131,321 | 1.0            | -           | \$ 138,872 | -           | \$ -       |                |
| Supervising Librarian/ Senior Librarian | Main     | 1.0        | -    | \$ 99,410   | -          | \$ -           | 1.0        | -          | \$ 99,410   | 1.0        | -              | \$ 100,521 | 1.0  | -           | \$ 104,699 | 1.0            | -           | \$ 110,720 | -           | \$ -       |                |
| Librarian                               | Main     | 5.0        | -    | \$ 454,890  | -          | \$ -           | 5.0        | -          | \$ 454,890  | 5.0        | -              | \$ 459,427 | 5.0  | -           | \$ 479,031 | 2.0            | -           | \$ 202,630 | -           | \$ -       |                |
| Supervising Associate                   | Main     | 1.0        | -    | \$ 85,755   | -          | \$ -           | 1.0        | -          | \$ 85,755   | 1.0        | -              | \$ 86,613  | 1.0  | -           | \$ 90,318  | 1.0            | -           | \$ 95,511  | -           | \$ -       |                |
| Customer Experience Specialist          | Main     | 2.0        | -    | \$ 152,386  | -          | \$ -           | 2.0        | -          | \$ 152,386  | 2.0        | -              | \$ 154,297 | 2.0  | -           | \$ 160,516 | 2.0            | -           | \$ 166,516 | -           | \$ -       |                |
| Customer Experience Assistant           | Main     | 10.0       | -    | \$ 657,241  | -          | \$ -           | 10.0       | -          | \$ 657,241  | 10.0       | -              | \$ 663,871 | 10.0 | -           | \$ 692,250 | 3.0            | -           | \$ 219,616 | -           | \$ -       |                |
| Customer Experience Clerk               | Main     | 4.8        | -    | \$ 208,572  | -          | \$ -           | 4.8        | -          | \$ 208,572  | 4.8        | -              | \$ 210,662 | 4.8  | -           | \$ 210,843 | 1.6            | -           | \$ 74,322  | -           | \$ -       |                |
| Supervising Librarian                   | Tillicum | 1.0        | -    | \$ 99,410   | \$ 99,410  | 1.0            | -          | \$ 99,410  | 1.0         | -          | \$ 100,521     | 1.0        | -    | \$ 104,699  | 1.0        | -              | \$ 110,720  | 1.0        | -           | \$ 110,720 |                |
| Customer Experience Specialist          | Tillicum | 1.0        | -    | \$ 76,193   | \$ 76,193  | 1.0            | -          | \$ 76,193  | 1.0         | -          | \$ 77,149      | 1.0        | -    | \$ 80,258   | 1.0        | -              | \$ 84,873   | 1.0        | -           | \$ 84,873  |                |
| Customer Experience Assistant           | Tillicum | 2.0        | -    | \$ 131,448  | \$ 131,448 | 2.0            | -          | \$ 131,448 | 2.0         | -          | \$ 132,774     | 2.0        | -    | \$ 138,450  | 2.0        | -              | \$ 146,411  | 2.0        | -           | \$ 146,411 |                |
| Support Personnel, Pro-rated            |          |            |      |             |            |                |            |            |             |            |                |            |      |             |            |                |             |            |             |            |                |
| Customer Experience support personnel   |          |            |      | \$ 278,480  | \$ 46,413  | \$ 324,894     |            |            | \$ 278,480  | \$ 46,413  | \$ 324,894     |            |      | \$ 281,629  | \$ 46,938  | \$ 328,567     |             |            | \$ 208,601  | \$ 52,150  | \$ 260,751     |
| Collection Management                   |          |            |      | \$ 209,201  | \$ 34,867  | \$ 244,068     |            |            | \$ 209,201  | \$ 34,867  | \$ 244,068     |            |      | \$ 211,858  | \$ 35,310  | \$ 247,167     |             |            | \$ 163,579  | \$ 40,895  | \$ 204,473     |
| Other support personnel                 |          |            |      | \$ 883,886  | \$ 147,314 | \$ 1,031,200   |            |            | \$ 883,886  | \$ 147,314 | \$ 1,031,200   |            |      | \$ 892,893  | \$ 148,816 | \$ 1,041,709   |             |            | \$ 738,912  | \$ 184,728 | \$ 923,639     |
| <b>Total FTE</b>                        |          |            |      | <b>28.8</b> | <b>4</b>   | <b>28.8</b>    |            |            | <b>28.8</b> | <b>4</b>   | <b>28.8</b>    |            |      | <b>28.8</b> | <b>4</b>   | <b>28.8</b>    |             |            | <b>10.6</b> | <b>4</b>   | <b>14.6</b>    |

\* 2023 Main Library FTE inventory decreased to reflect interim downtown

2019 Workload Indicators

| Workload Indicators                | PCLS          | Main         | Tillicum   | Total Lakewood | Puyallup     | Richland     | Longview     |
|------------------------------------|---------------|--------------|------------|----------------|--------------|--------------|--------------|
| 2019 Legal Service Area Population | 617,199       | -            | -          | 63,619         | 41,572       | 56,852       | 54,271       |
| Total Annual Circulation           | 5,918,248     | 502,738      | 33,158     | 535,896        | 278,740      | 641,072      | 415,725      |
| Circulation per Capita             | 9.6           | -            | -          | 8.4            | 6.7          | 11.3         | 7.7          |
| Operating Expenditures             | \$ 35,007,546 | \$ 4,200,906 | \$ 700,151 | \$ 4,901,056   | \$ 2,879,697 | \$ 2,283,750 | \$ 2,015,075 |
| Operating Expenditure-per-Capita   | \$ 57         | -            | -          | \$ 77          | \$ 69        | \$ 40        | \$ 37        |