



CONTRACT PROVISIONS

**Contract Documents
Bid Proposal
Project Specifications
and Special Provisions**

for

**South Tacoma Way – 96th to Steilacoom Overlay
City Project No. 302.0151
Federal Aid No. STBGUL-2977(012)**

September 2024

**CITY OF LAKEWOOD
PUBLIC WORKS DEPARTMENT
6000 Main Street SW
Lakewood, WA 98499-5027**

CONTRACT PROVISIONS

for

**South Tacoma Way – 96th to Steilacoom Overlay
City Project No. 302.0151
Federal Aid No. STBGUL-2977(012)**

September 2024

Prepared by:

*City of Lakewood
6000 Main ST SW
Lakewood, WA 98499*

The above mentioned Contract Provisions have been reviewed and approved for advertisement. Such review includes all contract documents, specifications, and plans associated with the project.

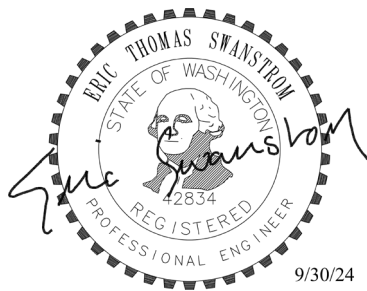

Prepared by: Timothy J. Motoh, E.I.T.

Project Engineer: Eric Swanstrom, P.E.

Approved by: Troy Pokswinski, P.E.

CONTRACT PROVISIONS

TABLE OF CONTENTS

South Tacoma Way – 96th to Steilacoom Overlay City Project No. 302.0151 Federal Aid No. STBGUL-2977(012)

September 2024

PART I – CONTRACT DOCUMENTS

VICINITY MAP.....	i
ADVERTISEMENT FOR BIDS.....	ii
BIDDERS CHECKLIST	iii
BIDDER INQUIRY FORM	iv
LOCAL AGENCY CERTIFICATION FOR FEDERAL-AID CONTRACTS.....	vi
BID FORM.....	vii
BID SCHEDULE	viii
BIDDER INFORMATION AND SIGNATURE	x
DEPOSIT OR BID BOND FORM.....	xii
BID BOND.....	xiii
NON-COLLUSION DECLARATION	xiv
DBE UTILIZATION CERTIFICATION.....	xv
DBE WRITTEN CONFIRMATION DOCUMENT	xvii
DBE BID ITEM BREAKDOWN FORM	xviii
DBE TRUCKING CREDIT FORM.....	xx
WSDOT BIDDER QUESTIONNAIRE (WSDOT FORM 272-022).....	xxii
BIDDER’S CONSTRUCTION EXPERIENCE.....	xxiv
CONTRACT AGREEMENT	xxv
PUBLIC WORKS PERFORMANCE BOND.....	xxix
PUBLIC WORKS PAYMENT BOND	xxx
E-VERIFY REQUIREMENTS FOR CONTRACTORS	xxxii
E-VERIFY AFFIDAVIT OF COMPLIANCE	xxxiii
CERTIFICATION OF COMPLIANCE WITH WAGE PAYMENT STATUTES.....	xxxiii

PART II – FEDERAL AID PROVISIONS

PART III – SPECIAL PROVISIONS

APPENDICES

- Appendix A – State Prevailing Wage Rates
- Appendix B – Federal Wage Rates
- Appendix C – Standard Plans and Details

PART IV – PROJECT PLANS

VICINITY MAP

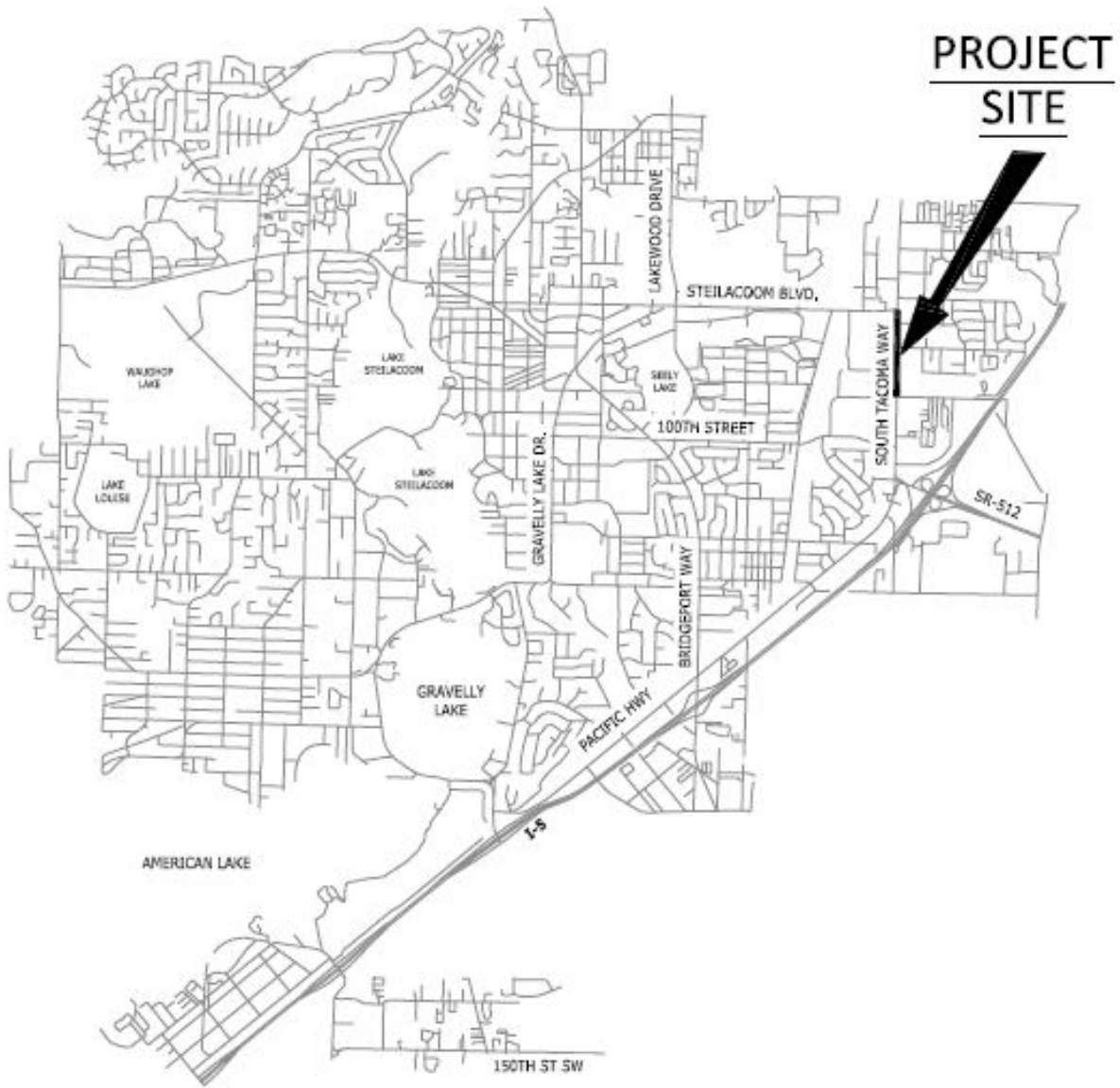

ADVERTISEMENT FOR BIDS

South Tacoma Way – 96th to Steilacoom Overlay City Project No. 302.0151 Federal Aid No. STBGUL-2977(012)

Sealed bids will be received by the City of Lakewood at the office of the City Clerk at 6000 Main Street SW, Lakewood, Washington 98499-5027, until **2:00 p.m. on Tuesday October 30, 2024**, and not later, and will then be opened and publicly read aloud in the Council Chambers shortly thereafter.

This contract provides for the construction of:

Reconstruct the wearing course of asphalt along South Tacoma Way between 96th Street SW and Steilacoom Boulevard, pavement repair, grinding, two-inch overlay, channelization, upgrading sidewalk ramps to conform to current ADA requirements and signage.

Plans, specifications, addenda and plan holders list for this project are available on-line through Builders Exchange of Washington, Inc. at <http://www.bxwa.com>. Click on: "Posted Projects", "Public Works", "City of Lakewood", "Projects Bidding". Bidders are encouraged to "Register as a Bidder" in order to receive automatic email notification of future addenda and to be placed on the "Bidders List". Contact Builders Exchange of Washington at (425) 258-1303 should you require further assistance. Informational copies of any available maps, plans and specifications are on file for inspection in the office of the Lakewood Public Works Engineering Director. Questions can be directed to Eric Swanstrom, P.E. at (253) 983-7751.

Bidders shall be qualified for the type of work proposed. A Bidder's Construction Experience form is included in the Contract Provisions.

All bids shall be submitted using the prescribed Bid Forms and in the manner as stated in this advertisement and in the Bid Documents, and said bids shall be accompanied by a bid deposit in the form of cash, cashier's check, certified check, postal money order, or a surety bond to the City of Lakewood in the amount of five percent (5%) of the total amount of the bid. **Faxed bids and/or surety bonds will not be accepted.**

Bids must be submitted in a sealed envelope with the outside clearly marked with the bid opening date and time, the project name and number as it appears in this advertisement and the name and address of the bidder. Bids shall be addressed to the City Clerk, City of Lakewood, 6000 Main Street SW, Lakewood, Washington 98499-5027 or hand delivered to the first floor receptionist.

The City of Lakewood in accordance with Section 504 of the Rehabilitation Act (Section 504) and the Americans with Disabilities Act (ADA), commits to nondiscrimination on the basis of disability, in all of its programs activities. This material can be made available in an alternate format by contacting Tim Motoh (tmotoh@cityoflakewood.us, 253-983-7777).

The City of Lakewood, in accordance with Title VI of the Civil Rights Act of 1964, (78 Stat. 252, 42 U.S.C. 2000d to 2000d-4) and the Regulations, hereby notifies all bidders that it will affirmatively ensure that in any contract entered into pursuant to this advertisement, disadvantaged business enterprises will be afforded full and fair opportunity to submit bids in response to this invitation and will not be discriminated against on the grounds of race, color, or national origin in consideration for an award.

There is a Disadvantaged Business Enterprise Participation goal of **17%** for this project. There is a Training goal of **0 Hours** for this project.

The City of Lakewood reserves the right to waive informalities in the bidding, accept a proposal of the lowest responsible bidder, reject any or all bids, republish the call for bids, revise or cancel the work, or require the work to be done in another way if the best interest of the City is served.

Brianna M. Schumacher
City Clerk

Daily Journal of Commerce
Tacoma News Tribune

Publish: October 9, 16, & 23, 2024
Publish: October 9, 16, & 23, 2024

BIDDERS CHECKLIST

1. Have the bid forms been properly signed?
2. Have you bid on all items?
3. Is the contractor's state license number shown on the bid form?
4. Has a Bid Deposit or Bid Bond been included?
5. Has the DBE Utilization Certification (272-056) been completed and signed?
6. Has the DBE Written Confirmation Document(s) (422-031) been completed and signed?
7. Has WSDOT Form 272-022 – Bidder Questionnaire been completed and signed?
8. Have you attached your Non-Collusion Declaration to your bid proposal package?
9. Has the Bidder's Construction Experience form been filled out?

The following forms are to be executed after the contract is awarded:

- A. Contract - To be executed by the successful Bidder and the City.
- B. Contract Bond (Performance and Payment Bond) - To be executed on the form provided by City, by the successful Bidder and its surety company. ***To include name and address of surety and power of attorney of signatory.***
- C. E-Verify Affidavit of Compliance completed and signed.
- D. Certification of Compliance with Wage Payment Statutes.
- E. Insurance certificate(s).
- F. Labor and Industries Forms.
- G. City of Lakewood Business License – Copy to be provided by contractor at pre-construction conference.

BIDDER INQUIRY FORM
Public Works Department

The responses to Contractor's inquiries, unless incorporated into a formal addendum to the Contract, are not part of the Contract and are provided for the Contractor's convenience only. The responses may be considered along with all other information furnished to prospective Bidders for the purpose of Bidding on the project. The use of information provided in the responses to Contractor's inquiries is not to be construed in any way as a waiver of the provisions nor excuse the Contractor from full compliance with the Contract requirements. Bidders are cautioned that subsequent responses or Contract addenda may affect or vary a response previously given and any such subsequent response or addenda should be taken into consideration when submitting a Bid for the project. Inquiries submitted within forty-eight (48) hours of the Bid opening might not be addressed.

Bidder inquiries may be e-mailed to eswanstrom@cityoflakewood.us or submitted attention Eric Swanstrom, City of Lakewood Public Works, 6000 Main St. SW, Lakewood, WA 98499.

Company Name:

Contact Name:

Phone Number:

e-mail Address:

INQUIRY

Bidder Inquiry No. ___ of ___ (Include specific references to items, Specifications, and/or plan sheets with your inquiry.)
City of Lakewood Response - Name: _____ Phone: _____ Date: _____

ADDITIONAL INQUIRIES:

Bidder Inquiry No. ___ of ___ (Include specific references to items, Specifications, and/or plan sheets with your inquiry.)
City of Lakewood Response - Name: _____ Phone: _____ Date: _____

Bidder Inquiry No. ___ of ___ (Include specific references to items, Specifications, and/or plan sheets with your inquiry.)
City of Lakewood Response - Name: _____ Phone: _____ Date: _____

LOCAL AGENCY CERTIFICATION FOR FEDERAL-AID CONTRACTS

The prospective participant certifies by signing and submitting this bid or proposal, to the best of his or her knowledge and belief, that:

(1) No Federal appropriated funds have been paid or will be paid, by or on behalf of the undersigned, to any person for influencing or attempting to influence an officer or employee of any Federal agency, a Member of Congress, an officer or employee of Congress, or an employee of a Member of Congress in connection with the awarding of any Federal contract, the making of any Federal grant, the making of any Federal loan, the entering into of any cooperative agreement, and the extension, continuation, renewal, amendment, or modification of any Federal contract, grant, loan or cooperative agreement.

(2) If any funds other than Federal appropriated funds have been paid or will be paid to any person for influencing or attempting to influence an officer or employee of any Federal agency, a Member of Congress, an officer or employee of Congress, or an employee of a Member of Congress in connection with this Federal contract, grant, loan, or cooperative agreement, the undersigned shall complete and submit Standard Form-LLL, "Disclosure Form to Report Lobbying," in accordance with its instructions.

This certification is material representation of the fact upon which reliance was placed when this transaction was made or entered into. Submission of this certification is a prerequisite for making or entering into this transaction imposed by Section 1352, Title 31, U.S. Code. Any person who fails to file the required certification shall be subject to a civil penalty of not less than \$10,000 and not more than \$100,000 for each failure.

The prospective participant also agrees by submitting his or her bid or proposal that he or she shall require that the language of this certification be included in all lower tier subcontracts, which exceed \$100,000 and that all such sub recipients shall certify and disclose accordingly.

BID FORM

TO: City of Lakewood, City Clerk's Office

ADDRESS: 6000 Main Street SW, Lakewood, WA 98499-5027

PROPOSAL TO LAKEWOOD CITY COUNCIL, LAKEWOOD, WASHINGTON

PROJECT: South Tacoma Way – 96th to Steilacoom Overlay
City Project No. 302.0151
Federal Aid No. STBGUL-2977(012)

Bidder _____

Address _____

Date _____

Contractor's State Lic. # _____

Bidders Declaration of Understanding

The Bidder, in compliance with the City's Advertisement for Bids and Instructions for Bidders for **South Tacoma Way – 96th to Steilacoom Overlay**, having examined the specifications, drawings, related documents, and the site of the proposed work, and being familiar with all of the conditions surrounding the work of the proposed project including the availability of material and labor, hereby proposes to furnish all labor, materials, tools, expendable equipment, affidavits of prevailing wages paid, utility and transportation services, and incidentals, necessary to perform the complete contract, in a workmanlike manner, and as required by and in strict conformance with the Standard Specifications, Special Provisions, Addenda and plans, all for the rates and lump sum prices listed below. These prices shall cover all expenses incurred in performing the work required under the contract documents, for which this bid is a part. All sales tax shall be included in the lump sum and unit prices within this bid.

Bid Schedule
South Tacoma Way – 96th to Steilacoom Overlay
City Project No. 302.0151
Federal Aid No. STBGUL-2977(012)

Item No.	Section Number	Description	Quantity	Unit	Unit Price	Amount
1	1-09.7	Mobilization	1	LS		
2	1-04.4(1)	Minor Change	10,000	FA	\$1.00	\$10,000
3	1-05.4	Roadway Surveying	1	LS		
4	1-07.15(1)	SPCCC Plan	1	LS		
5	1-10.5(2)	Traffic Control Supervisor	1	LS		
6	1-10.5(2)	Pedestrian Traffic Control	1	LS		
7	1-10.5(2)	Flaggers (Min. Bid \$70/hr)	480	HR		
8	1-10.5(2)	Other Traffic Control Labor (Min. Bid \$70/hr)	60	HR		
9	1-10.5(2)	Other Temporary Traffic Control Devices	1	LS		
10	1-10.5(2)	Work Zone Safety Contingency	2,000	FA	\$1.00	\$2,000
11	2-02.5	Sawcutting	230	LF		
12	4-04.5	Crushed Surfacing Top Course	21	TON		
13	5-04.5	HMA Cl. 1/2" PG 58H-22	2,050	TON		
14	5-04.5	HMA for Pavement Repair Cl. 1/2" PG 58H-22	65	TON		
15	5-04.5	Pavement Repair Excavation Incl. Haul	95	SY		
16	5-04.5	Plaining Bituminous Pavement	7,515	SY		
17	5-04.5(2)	Asphalt Cost Price Adjustment	1	EST	\$10,000	\$10,000
18	7-05.5	Adjust Manhole	6	EA		
19	7-05.5	Adjust Catch Basin	5	EA		

20	7-20.5	Adjust Valve/Junction/Meter Box	6	EA		
21	8-01.5	Erosion Control and Water Pollution Prevention	1	LS		
22	8-04.5	Cement Concrete Traffic Curb and Gutter	140	LF		
23	8-04.5	Cement Concrete Pedestrian Curb	60	LF		
24	8-09.5	Raised Pavement Marker Type 2	200	EA		
25	8-14.5	Detectible Warning Surface – Cast Iron	32	SF		
26	8-14.5	Cement Concrete Sidewalk	45	SY		
27	8-14.5	Cement Concrete Curb Ramp Type Parallel	4	EA		
28	8-22.5	Profiled Plastic Lane Line	11,730	LF		
29	8-22.5	Plastic Wide Lane Line	5,100	LF		
30	8-22.5	Plastic Dotted Extension Line	230	LF		
31	8-22.5	Plastic Stop Line	36	LF		
32	8-22.5	Plastic Traffic Arrow	23	EA		
33	8-22.5	Plastic Traffic Letter	4	EA		
34	8-22.5	Plastic Bicycle Lane Symbol	14	EA		
35	8-22.5	Plastic Crosswalk Line	300	SF		
36	8-23.5	Temporary Pavement Marking – Short Duration	16,830	LF		
TOTAL						

BIDDER INFORMATION AND SIGNATURE

The Bidder proposes to accept as full payment for the work proposed herein, the amount computed under the provisions of the Contract Documents. The undersigned bids for the following described project:

**South Tacoma Way – 96th to Steilacoom Overlay
City Project No. 302.0151
Federal Aid No. STBGUL-2977(012)**

Addenda Acknowledgment

By signing below, Bidder acknowledges receipt and understanding of the following Addenda to the Contract Provisions:

Addendum No.	Date of Receipt	Signature
1		
2		
3		
4		
5		

Note: Failure to acknowledge receipt of Addenda may be considered as an irregularity in the Bid Proposal and the City reserves the right to determine whether the bid will be disqualified.

The party by whom this bid is submitted and by whom the contract will be entered into, in the event the award is made to this party, is:

Contractor (Firm Name)

Signature

Address

Name (Print) & Title

Phone Number

Date of Signing

Contractor's Washington State License Number

(Indicate whether contractor is partnership, joint venture, corporation, or sole proprietorship)*

*If Bidder is a corporation, write State of Incorporation under signature. If partnership, give full names of all partners.

The name of the President, Treasurer, and/or Manager of the bidding corporation, or the names of all persons and parties interested in this bid as partners or principals, are as follows:

Name	Address

If Sole Proprietor or Partnership

IN WITNESS hereto, the undersigned has set his (its) hand this _____ day of _____, 20__.

Signature of Bidder

Title

If Corporation

IN WITNESS WHEREOF, the undersigned corporation has caused this instrument to be executed by its duly authorized officers this _____ day of _____, 20__.

Attest:

Name of Corporation

Secretary

by _____

Title _____

Sworn to me before me this _____ day of

_____, 20__.

Notary Public in and for the State of
Washington Residing at

NOTES:

If the Bidder is a co-partnership, give firm name under which business is transacted; proposal must be executed by a partner. If the Bidder is a corporation, proposal must be executed in the corporate name by the president or vice-president (or any other corporate officer accompanied by evidence of authority to sign).

BID BOND

KNOW ALL MEN BY THESE PRESENTS:

That we, _____ as Principal and _____ as Surety, are held and firmly bound unto the CITY OF LAKEWOOD as Obligee, in the penal sum of _____ Dollars, for the payment of which the Principal and the Surety bind themselves, their heirs, executors, administrators, successors and assigns, jointly and severally, by these presents.

The condition of this obligation is such that if the Obligee shall make any award to the Principal for:

_____ according to the terms of the bid made by the Principal, and the Principal shall duly make and enter into a contract with the Obligee in accordance with the terms of said bid and award and shall give bond for the faithful performance thereof, with Surety or Sureties approved by the Obligee; or if the Principal shall, in case of failure so to do, pay and forfeit to the Obligee the penal amount of the deposit specified in the advertisement for bids, then this obligation shall be null and void; otherwise it shall be and remain in full force and effect and the Surety shall forthwith pay and forfeit to the Obligee, as penalty and liquidated damages, the amount of this bond.

SIGNED, SEALED AND DATED THIS _____ day of _____, 20 ____.

_____ Principal
_____ Surety

Signature of Authorized Official Attorney in Fact (Attach Power of Attorney)

Title (Typed)

Name and address of local _____
Agent and/or Surety _____
Company: _____

Surety companies executing bonds must appear on the current Authorized Insurance List in the State of Washington per Section 1-02.7 of the Standard Specifications.

Failure to return this Declaration as part of the bid proposal package will make the bid nonresponsive and ineligible for award.

NON-COLLUSION DECLARATION

I, by signing the proposal, hereby declare, under penalty of perjury under the laws of the United States that the following statements are true and correct:

1. That the undersigned person(s), firm, association or corporation has (have) not, either directly or indirectly, entered into any agreement, participated in any collusion, or otherwise taken any action in restraint of free competitive bidding in connection with the project for which this proposal is submitted.
2. **That by signing the signature page of this proposal, I am deemed to have signed and to have agreed to the provisions of this declaration.**

NOTICE TO ALL BIDDERS

To report rigging activities call:

1-800-424-9071

The U.S. Department of Transportation (USDOT) operates the above toll-free "hotline" Monday through Friday, 8:00 a.m. to 5:00 p.m., eastern time. Anyone with knowledge of possible bid rigging, bidder collusion, or other fraudulent activities should use the "hotline" to report such activities.

The "hotline" is part of USDOT's continuing effort to identify and investigate highway construction contract fraud and abuse and is operated under the direction of the USDOT Inspector General. All information will be treated confidentially and caller anonymity will be respected.

Instructions for Disadvantaged Business Enterprise Utilization Certification Form

Box 1: Name of Bidder (Proposal holder) submitting Bid.

Box 2: Name of the Project.

Column 1: Name of the Disadvantaged Business Enterprise (DBE). DBE firms can be found using the Diversity Management and Compliance System web page: <https://wsdot.diversitycompliance.com>. Repeat the name of the DBE for each Project Role that will be performed.

Column 2: The Project Role that the DBE will be performing as follows;

- Prime Contractor
- Subcontractor
- Subcontractor (Force Account)
 - Work sublet as Force Account must be listed separately.
- Manufacturer
- Regular Dealer
 - Work sublet to a Regular Dealer must be listed separately.
 - Regular Dealer status must be approved prior to Bid submittal by the Office of Equal Opportunity, Washington State Department of Transportation, on each Contract.
- Broker
 - Work sublet to a Broker must be listed separately.

List each project role to be performed by a single DBE individually on a separate row. The role is used to determine what portion of the amount to be subcontracted (Column 4) may be applied toward meeting the goal (column 5).

Column 3: Provide a description of work to be performed by the DBE. The work to be performed must be consistent with the Certified Business Description of the DBE provided at the Diversity Management and Compliance System web page <https://wsdot.diversitycompliance.com>

- A Bidder subletting a portion of a bid item shall state “**Partial**” and describe the Work that is included.
 - For example; “Electrical (Partial) – Trenching”.
- “Mobilization” will not be accepted as a description of Work.

Column 4: List the total amount to be subcontracted to each DBE for each Project Role they are performing.

Column 5: This is the dollar amount for each line listed in the certification that the prime intends to apply towards meeting the COA Contract goal. It may be that only a portion of the amount subcontracted to a DBE in Column 4 is eligible to be credited toward meeting the goal **See Note 1, Note 2, Note 3**. The Contracting Agency will utilize the sum of this column (Box 4) to determine whether or not the bidder has met the goal. In the event of an arithmetic error in summing column 5 or an error in making appropriate reductions in the amounts in column four, **See Note 1, Note 2, Note 3**, then the mathematics will be corrected and the total (Box 4) will be revised accordingly.

Note 1: For Work sublet as Force Account the bidder **may only claim 50%** of the amount subcontracted (Column 4) towards meeting the goal (Column 5). This information will be used to demonstrate that the DBE contract goal is met at the time that the bidder submits their bid. For example; amount sublet as force account = \$100,000 (Column 4) equates to $(\$100,000 \times 50\%) = \$50,000$ (Column 5) to be applied towards the goal.

Note 2: For Work sublet to a Regular Dealer the bidder **may only claim 60%** of the cost of the materials or supplies (Column 4) towards meeting the goal (Column 5). For example; Material cost = \$100,000 (Column 4) equates to $(\$100,000 \times 60\%) = \$60,000$ (Column 5) to be applied towards the goal

Note 3: For Work sublet to a Broker the bidder **may only claim the fees** paid to a Broker towards meeting the goal (Column 4). For example; amount sublet to a broker = \$100,000 (Column 4) equates to $(\$100,000 \times \text{reasonable fee } \%) = \$$ (Column 5) to be applied towards the goal.

Box 3: Box 3 is the COA Contract goal which is the minimum required DBE participation. The goal stated in the Contract will be in terms of a dollar amount or a percentage in the Contract. When expressed as a percentage you must multiply the percentage times the sum total of all bid items as submitted in the Bidder's Proposal to determine the dollar goal and write it in Box 3. In the event of an error in this box, the Contracting Agency will revise the amount accordingly.

Box 4: Box 4 is the sum of the values in column 5. **This value must equal or exceed the COA Contract goal amount written in Box 3 or;**

Box 5: Check Box 5 if insufficient DBE Participation has been achieved and a good faith effort is required. Refer to the subsection titled, *Selection of Successful Bidder/Good Faith Efforts (GFE)* in the Contract.

See the *Disadvantaged Business Enterprise Participation* specification in the Contract for more information.

See Contract Provisions: *DBE Document Submittal Requirements*
Disadvantaged Business Enterprise Participation

THIS FORM SHALL ONLY BE SUBMITTED TO A DBE THAT IS LISTED ON THE CONTRACTOR'S DISADVANTAGED BUSINESS ENTERPRISE UTILIZATION CERTIFICATION.

THE CONTRACTOR SHALL COMPLETE PART A PRIOR TO SENDING TO THE DBE.

PART A: To be completed by the bidder

The entries below shall be consistent with what is shown on the Bidder's Disadvantaged Business Enterprise Utilization Certification. Failure to do so will result in Bid rejection.

Contract Title: _____

Bidder's Business Name: _____

DBE's Business Name: _____

Description of DBE's Work: _____

Dollar Amount to be Applied Towards DBE Goal: _____

Dollar Amount to be Subcontracted to DBE*: _____
*Optional Field

PART B: To be completed by the Disadvantaged Business Enterprise

As an authorized representative of the Disadvantaged Business Enterprise, I confirm that we have been contacted by the Bidder with regard to the referenced project for the purpose of performing the Work described above. If the Bidder is awarded the Contract, we will enter into an agreement with the Bidder to participate in the project consistent with the information provided in Part A of this form.

Name (printed): _____

Signature: _____

Title: _____

Address: _____ Date: _____

Disadvantaged Business Enterprise (DBE) Bid Item Breakdown Form

1. Contract Number	2. Contract Name
3. Prime Contractor	4. Prime Contractor Representative Name
5. Prime Contractor Representative Phone Number	6. Prime Contractor Representative Email

Column 1 Name of UDBE <small>(See Instructions)</small>	Column 2 Bid Item # <small>(See Instructions)</small>	Column 3 Full/Partial <small>(See Instructions)</small>	Column 4 Quantity <small>(See Instructions)</small>	Column 5 Description <small>(See Instructions)</small>	Column 6 Unit Price <small>(See Instructions)</small>	Column 7 Total Unit Cost <small>(See Instructions)</small>	Column 8 Dollar Amount to be Applied Towards Goal <small>(See Instructions)</small>
Subtotal:							
Name of UDBE	Bid Item #	Full/Partial	Quantity	Description	Unit Price	Total Unit Cost	Dollar Amount to be Applied Towards Goal
Subtotal:							
Name of UDBE	Bid Item #	Full/Partial	Quantity	Description	Unit Price	Total Unit Cost	Dollar Amount to be Applied Towards Goal
Subtotal:							
Name of UDBE	Bid Item #	Full/Partial	Quantity	Description	Unit Price	Total Unit Cost	Dollar Amount to be Applied Towards Goal
Subtotal:							
Subtotal:							
TOTAL UDBE Dollar Amount:							

Instructions for Disadvantaged Business Enterprise (DBE) Bid Item Breakdown Form

Box 1: Provide the Contract Number as stated in the project information webpage.

Box 2: Provide the Name of the project as stated in the project information webpage.

Box 3: Provide the Name of the bidder (Proposal holder) submitting Bid.

Box 4: Provide the name of the prime contractor's representative available to contact regarding this form.

Box 5: Provide the phone number of the prime contractor's representative available to contact regarding this form.

Box 6: Provide the email of the prime contractor's representative available to contact regarding this form.

Column 1: Provide the Name of the Disadvantaged Business Enterprise (DBE) Firm. DBE Firms can be found using the search tools under the Firm Certification section of the Diversity Management and Compliance System (DMCS) webpage <https://wsdot.diversitycompliance.com>.

Column 2: Provide the Bid Item Number (as it appears in the engineer's estimate bid check report) available on the project information webpage.

Column 3: If the DBE is performing only part of the bid item, mark "Partial". If the DBE is performing the entire bid item, mark "Complete".

Column 4: Provide the estimated quantity for the specific bid item. For trucking firms, use hour or another unit of measure.

Column 5: Provide a description of the work to be performed by the DBE.

Column 6: Provide the price per unit and specify the type of unit used. For trucking firms, use hour or another unit of measure.

Column 7: Provide the estimated total unit cost amount per bid item.

Column 8: Provide the amount of the bid item being used to fulfil the DBE goal. The work to be performed must be consistent with the Certified Business Description of the DBE provided in the DMCS webpage <https://wsdot.diversitycompliance.com>. Mobilization up to 10% is acceptable. If mobilization is more than 10% additional information and/or justification may be requested. The total amount shown for each DBE shall match the amount shown on the DBE Utilization Certification Form.

Use Additional Sheets if necessary.

PART A: TO BE COMPLETED BY THE BIDDER

This form is in support of the trucking commitment identified on the DBE Utilization Certification Form submitted with the proposal. Please note that DBE's must be certified prior to time of submittal.

Federal Aid #		Contract #	Project Name
If listing items by hours, or by lump sum amounts, please provide calculations to substantiate the quantities listed.			
Bid Item	Item Description		

Use additional sheets as necessary.

Bidder		Name/Title (please print)	
Phone	Fax	Signature	
Address			
Email		I certify that the above information is complete and accurate.	
		Date	

PART B: TO BE COMPLETED BY THE DBE TRUCKING FIRM

Note: DBE trucking firm participation may only be credited as DBE participation for the value of the hauling services, not for the materials being hauled unless the trucking firm is also recognized as a supplier of the materials used on the project and approved for this project as a regular dealer.

- Type of Material expected to be hauled? _____
- Number of fully operational trucks expected to be used on this project? _____ Tractor/trailers: _____ Dump trucks: _____
- Number of trucks and trailers owned by the DBE that will be used on this project? _____ Tractor/trailers: _____ Dump trucks: _____
- Number of trucks and trailers leased by the DBE that will be used on this project? _____ Tractor/trailers: _____ Dump trucks: _____

DBE Firm Name		Name/Title (please print)	
Certification Number			
Phone	Fax	Signature	
Address			
Email		I certify that the above information is complete and accurate.	
		Date	

Submit this form to in accordance with section 1-02.9 of the Contract.

Instruction to Bidder: The Bidder shall complete and submit the Disadvantaged Business Enterprise (DBE) Trucking Credit Form in accordance with Section 1-02.9 of the Contract.

INSTRUCTIONS

Please note – All Fields are required

PART A: TO BE COMPLETED BY THE BIDDER

Federal Aid: Include the project federal-aid number.

County: Specify the County where the project will take place.

Contract #: Specify the Project Contract Number which can be found in the Engineer's estimate bid check report. **Bid Item:** Provide the Bid Item Number (as it appears in the engineer's estimate bid check report) for which trucking services will be utilized.

Item Description: Provide description of the bid item (as it appears in the engineer's estimate bid check report) for which trucking will be utilized.

Bidder: In this section, provide the bidder's legal name, title, Business address, Phone and email.

The bidder's representative signature is required in addition to the date the form was signed.

PART B: TO BE COMPLETED BY THE DBE TRUCKING FIRM

Question 1: Specify type of material that will be hauled (i.e. Sand, HMA, gravel)

Question 2: Specify the total number of operational trucks that will be used on the project.

Question 3: Specify the total number of operational trucks and trailers owned by the DBE that will be used on the project. Question 4: Specify the total number of operational trucks and trailers leased by the DBE that will be used on the project.

DBE Firm: In this section, provide the DBE Firm's legal name, DBE Firm's representative legal name and title, certification

Number (Found in the firm's OMWBE Profile page in the OMWBE directory), Business address, Phone, fax and email.

The DBE Firm's representative signature is required in addition to the date the form was signed.

DOT Form 271-015A
Revised 06/2020



Bidder Questionnaire

Agency Name						Federal Aid Number		
Prime Contractor Name						Contract Number		
Contract Name								
Firm/ Subcontractor Name	Address (incl. Zipcode)	DBE Status	Race	Gender	NAICS Codes	Scope of Work	Firm Age	Firm Gross Receipts

If you have additional Firms or Subcontractors that submitted Bids, please complete additional forms.

Prime Contractor Signature Title Date

Form Instructions

The following information on each firm that submitted a bid is required as part of part of 49 CFR 26.11(c)(2):

Firm/Subcontractor Name: Enter the name of each firm or subcontractor who submitted a quote or a bid on the contract.

Address: Enter the date the main address of the firm/subcontractor. Include the zip code.

DBE Status: Enter the DBE status. *Options are DBE and Non-DBE.*

Race: Enter the race of the majority DBE Owner. *Options are "Black American", "Hispanic American", "Native American", "Asian-Pacific American", "Subcontinent Asian American", and "White".*

Gender: Enter the gender of the majority DBE Owner. *Options are "Female" and "Male".*

NAICS Codes: Enter the appropriate NAICS Codes for the work the bid was submitted.

Scope of Work: Enter the scope of the work the bid was submitted for.

Firm Age: Enter the age of the Firm.

Firm Gross Receipts: Enter the annual gross receipts. *Options are "Less than \$1 million", "\$1-\$3 million", "\$3-\$6 million", "\$6-\$10 million", "\$10-\$20 million", "\$20-\$30.72 million", "Greater than \$30.72 million".*

BIDDER'S CONSTRUCTION EXPERIENCE

All questions must be answered and the data given must be clear and comprehensive. If necessary, add separate sheets for items marked "*".

1. Name of Bidder:
2. Permanent main office address:
3. When organized:
4. Where incorporated:
5. How many years have you been engaged in the contracting business under your present firm name?
6. *Contracts on hand. (Schedule these, showing gross amount of each contract and the approximate anticipated dates of completion.)
7. *General character of work performed by your company:
8. *Have you ever failed to complete any work awarded to you?
If so, where and why?
9. *Have you ever defaulted on a contract?
10. *List the more important projects recently completed by your company, stating approximate cost for each, and the month and year completed.
11. *List your major equipment available for this contract:
12. *Experience in construction work similar in importance to this project:
13. Will you, upon request, fill out a detailed financial statement and furnish any other information that may be required by the City?
14. The undersigned hereby authorizes and requests any person, firm or corporation to furnish any information requested by the City of Lakewood.

Date: _____

By: _____

Title: _____

CONTRACT AGREEMENT
South Tacoma Way – 96th to Steilacoom Overlay
City Project No. 302.0151
Federal Aid No. STBGUL-0977(012)

THIS AGREEMENT, made and entered into this _____ day of _____, 20____, by and between the **CITY OF LAKEWOOD**, Washington, a municipal corporation, hereinafter referred to as the City, and _____, hereinafter called the Contractor.

WITNESSETH:

WHEREAS, the City desires to have certain services and/or work performed as hereinafter set forth requiring specialized skills and other supportive capabilities; and,

WHEREAS, the Contractor represents that the Contractor is qualified and possesses sufficient skills and the necessary capabilities, including technical and professional expertise where required, to perform the services set forth in this Agreement.

NOW THEREFORE, in consideration of the terms, conditions, covenants, and performance contained herein, the parties hereto agree as follows:

1. SCOPE OF SERVICES.

The Contractor shall perform such services and accomplish such work, including the furnishing of all materials and equipment necessary for full performance thereof, as are identified and designated as Contractor responsibilities throughout this Agreement and as detailed in the attached plans, specifications, addenda, and the 2024 Standard Specifications for Road, Bridge, Municipal Public Works Construction prepared by the Washington State Department of Transportation and the Washington State Chapter of the American Public Works Association herein after called the Standard Specification, and shall perform any alterations in or additions to the work provided under this contract and every part thereof.

2. TIME FOR PERFORMANCE AND LIQUIDATED DAMAGES.

A. The Contractor shall perform the work of the scope of service in accordance with the time for performance as specified in the Bid Form.

B. Liquidated damages shall apply as specified in the Bid Form.

3. COMPENSATION AND METHOD OF PAYMENT.

A. Payments for services provided hereunder shall be made following the performance of such services, unless otherwise permitted by law and approved in writing by the City.

B. No payment shall be made for any service rendered by the Contractor except for services identified and set forth in this agreement.

C. The City shall pay the Contractor for work performed under this Agreement as detailed in the Bid Schedule which is incorporated herein and made a part hereof by this reference.

D. The Contractor shall submit to the City, in accordance with the procedures specified in the Standard Specifications, and on forms approved by the City, a voucher or invoice for services rendered during the pay period. The City shall initiate authorization for payment after receipt of said approved voucher or invoice and shall make payment to the Contractor within approximately thirty (30) days thereafter.

4. INDEPENDENT CONTRACTOR RELATIONSHIP.

A. The parties intend that the relationship of an independent Contractor between the Contractor

and the City will be created by this Agreement. The City is interested primarily in the results to be achieved. The implementation of services will lie solely with the Contractor. No agent, employee, servant or representative of the Contractor shall be deemed to be an employee, agent, servant or representative of the City for any purpose, and the employees of the Contractor are not entitled to any of the benefits the City provides for its employees. The Contractor will be solely and entirely responsible for its acts and for the acts of its agents, employees, servants, subcontractors or representatives during the performance of this Agreement.

B. In the performance of the services herein contemplated the Contractor is an independent contractor with the authority to control and direct the performance of the details of the work, however, the results of the work contemplated herein must meet the approval of the City and shall be subject to the City's general rights of inspection and review to secure the satisfactory completion thereof.

5. CONTRACTOR'S EMPLOYEES – PREVAILING WAGE REQUIREMENTS.

The Contractor shall be responsible for payment of wages and salaries, plus all appropriate and timely employment related contributions, for all employees of the Contractor, including but not limited to Workers Compensation Insurance and Unemployment Insurance. The Contractor shall also comply with applicable prevailing wage requirements, and shall document the same to the City upon request, and shall file with the City appropriate affidavits, certificates and/or statements of compliance with the prevailing wage requirements. The Contractor shall also ensure that any sub-contractors or agents of the Contractor shall comply with the requirements hereof.

6. CONTRACTOR'S EMPLOYEES – EMPLOYMENT ELIGIBILITY REQUIREMENTS

The Contractor and any subcontractors shall comply with E-Verify as set forth in Lakewood Municipal Code Chapter 1.42. E-Verify is an Internet-based system operated by United States Citizenship and Immigration Services in partnership with the Social Security Administration. E-Verify is free to employers and is available in all 50 states. E-Verify provides an automated link to federal databases to help employers determine employment eligibility of new hires and the validity of their Social Security numbers. The Contractor shall enroll in, participate in and document use of E-Verify as a condition of the award of this contract. The Contractor shall continue participation in E-Verify throughout the course of the Contractor's contractual relationship with the City. If the Contractor uses or employs any subcontractor in the performance of work under this contract, or any subsequent renewals, modifications or extension of this contract, the subcontractor shall register in and participate in E-Verify and certify such participation to the Contractor. The Contractor shall show proof of compliance with this section, and/or proof of subcontractor compliance with this section, within three (3) working days of the date of the City's request for such proof.

7. BOND REQUIREMENTS.

The Contractor shall provide and deliver to the City, through its Contract Administrator identified below, such Performance Bond(s) as may be required by the City, in such amount(s) and form(s) as required by the City.

8. HOLD HARMLESS AND INDEMNIFICATION.

The Contractor shall indemnify and hold the City and its agents, employees, and/or officers, harmless from and shall process and defend at its own expense any and all claims, demands, suits, at law or equity, actions, penalties, losses, damages, or costs, of whatsoever kind or nature, brought against the City arising out of, in connection with, or incident to the execution of this Agreement and/or the Contractor's performance or failure to perform any aspect of this Agreement; provided, however, that if such claims are caused by or result from the concurrent negligence of the City, its agents, employees, and/or officers, this indemnity provision shall be valid and enforceable only to the extent of the negligence of the Contractor; and provided further, that nothing herein shall require the Contractor to hold harmless or defend the City, its agents, employees and/or officers from any claims arising from the sole negligence of the City, its agents, employees, and/or officers. No liability shall attach to the City by reason of entering into this Agreement except as expressly provided herein.

9. INSURANCE.

The Contractor shall obtain, and keep in force during the full term of this Agreement, Public Liability and Property Damage Insurance in accordance with Sections 1-07.18 of the APWA General Special Provisions to the Standard Specifications and the following additions:

A. The City shall be specifically named as **ADDITIONAL INSURED** in the insurance coverage required hereinabove. A certificate of such insurance or a copy of such insurance policy or policies shall be provided to the City within ten (10) working days after the execution of the Agreement. The Contractor's insurer shall agree to give the City thirty (30) days written notice of cancellation or reduction in coverage below the limits set forth herein. Coverage in the minimum amount set forth herein shall not be construed to relieve the Contractor from liability in excess of such coverage. Further, the City reserves all claims or rights of action against the Contractor as if the City were not named in the subject policy or policies.

10. COMPLIANCE WITH LAWS.

A. The Contractor, in the performance of the Agreement, shall comply with all applicable federal, state or local laws and ordinances, including regulations for licensing, certification and operation of facilities, programs and accreditation, and licensing of individuals, and any other standards or criteria as described in this Agreement to assure quality of services.

B. The Contractor specifically agrees to pay any applicable business and permit fees and taxes which may be due on account of this Agreement.

11. NONDISCRIMINATION.

A. The City is an equal opportunity employer.

B. In the performance of this Agreement, the Contractor will not discriminate against any employee or applicant for employment on the grounds of race, creed, color, national origin, sex, marital status, age, or the presence of any sensory, mental or physical handicap; provided that the prohibition against discrimination in employment because of handicap shall not apply if the particular disability prevents the proper performance of the particular worker involved. The Contractor shall ensure that applicants are employed, and that employees are treated during employment without discrimination because of their race, creed, color, national origin, sex, marital status, age, or the presence of any sensory, mental or physical handicap. Such action shall include, but not be limited to: employment, upgrading, demotion or transfers, recruitment or recruitment advertising, layoff or termination, rates of pay or other forms of compensation, and programs for training including apprenticeships. The Contractor shall take such action with respect to this Agreement as may be required to ensure full compliance with Chapter 49.60 Revised Code of Washington, Law Against Discrimination.

C. The Contractor will not discriminate against any recipient of any services or benefits provided for in this Agreement on the grounds of race, creed, color, national origin, sex, marital status, age or the presence of any sensory, mental or physical handicap.

D. If any assignment and/or subcontracting has been authorized by the City, said assignment or subcontract shall include appropriate safeguards against discrimination. The Contractor shall take such action as may be required to ensure full compliance with the provision in the immediately preceding paragraphs herein.

12. RESTRICTION AGAINST ASSIGNMENT.

The Contractor shall not assign this Contract or any interest herein, nor any money due or to become due hereunder without first obtaining the written consent of the City, nor shall the Contractor subcontract any part of the services to be performed hereunder, without first obtaining the consent of the City.

13. CONTINUATION OF PERFORMANCE.

In the event that any dispute or conflict arises between the parties while this Contract is in effect, the Contractor agrees that, notwithstanding such dispute or conflict, the Contractor shall continue to make a good faith effort to cooperate and continue work toward successful completion of assigned duties and responsibilities.

14. CONTRACT ADMINISTRATION.

This Contract shall be administered by _____ on behalf of the Contractor and by the City Manager or designee on behalf of the City. Any written notices required by terms of this Contract shall be served or mailed to the following address(es):

If to the City:

City of Lakewood
6000 Main Street SW
Lakewood, WA 98499

If to the Contractor:

15. CONSTRUCTION AND VENUE.

This Contract shall be construed in accordance with laws of the State of Washington. In the event of any litigation regarding the construction or effect of this Contract, or the rights of the parties pursuant to this Contract, it is agreed that venue shall be Pierce County, Washington.

16. TERMINATION AND SUSPENSION.

A. The City may terminate this Agreement upon not less than fifteen (15) days written notice to the Contractor if the services provided for herein are no longer needed from the Contractor.

B. If this Agreement is terminated through no fault of the Contractor, the Contractor shall be compensated for services performed prior to termination in accordance with the rate of compensation provided in the Contract Documents incorporated herein.

17. MERGER AND AMENDMENT.

This Contract contains the entire understanding of the parties with respect to the matters set forth herein and any prior or contemporaneous understandings are merged herein. This contract shall not be modified except by written instrument executed by all parties hereto.

IN WITNESS WHEREOF the parties hereto have caused this agreement to be executed the day and year first above written.

CITY OF LAKEWOOD, OWNER

CONTRACTOR

John J. Caulfield, City Manager

Name: _____

Title: _____

ATTEST:

Briana Schumacher, City Clerk

APPROVED AS TO FORM:

Heidi Wachter, City Attorney

PUBLIC WORKS PERFORMANCE BOND
to the City of Lakewood, WA

Bond No. _____

The City of Lakewood, Washington, (City) has awarded to _____
(Principal), a Contract for the construction of the project designated as Farwest DR SW Safe Routes to Schools,
Project No. 302.0164, in Lakewood, Washington (Contract), and said Principal is required under the terms of that
Contract to furnish a bond for performance of all obligations under the Contract.

The Principal, and _____ (Surety), a corporation organized under the laws
of the State of _____ and licensed to do business in the State of Washington as surety and
named in the current list of "Surety Companies Acceptable in Federal Bonds" as published in the Federal Register
by the Audit Staff Bureau of Accounts, U.S. Treasury Dept., are jointly and severally held and firmly bound to the
City of Lakewood, in the sum of _____ US Dollars
(\$ _____) Total Contract Amount, subject to the provisions herein.

This statutory performance bond shall become null and void, if and when the Principal, its heirs, executors,
administrators, successors, or assigns shall well and faithfully perform all of the Principal's obligations under the
Contract and fulfill all the terms and conditions of all duly authorized modifications, additions, and changes to said
Contract that may hereafter be made, at the time and in the manner therein specified; and if such performance
obligations have not been fulfilled, this bond shall remain in full force and effect.

The Surety agrees to indemnify, defend, and protect the City of Lakewood against any claim of direct or indirect
loss resulting from the failure of the Principal, its heirs, executors, administrators, successors, or assigns (or any of
the employees, subcontractors, or lower tier subcontractors of the Principal) to faithfully perform the Contract.

The Surety for value received agrees that no change, extension of time, alteration or addition to the terms of the
Contract, the specifications accompanying the Contract, or to the work to be performed under the Contract shall in
any way affect its obligation on this bond, and waives notice of any change, extension of time, alteration or addition
to the terms of the Contract or the work performed. The Surety agrees that modifications and changes to the terms
and conditions of the Contract that increase the total amount to be paid the Principal shall automatically increase the
obligation of the Surety on this bond and notice to Surety is not required for such increased obligation.

This bond may be executed in two (2) original counterparts, and shall be signed by the parties' duly authorized
officers. This bond will only be accepted if it is accompanied by a fully executed and original power of attorney for
the officer executing on behalf of the surety.

The Surety agrees to be bound by the laws of the state of Washington and subjected to the jurisdiction of the state of
Washington.

PRINCIPAL	SURETY
_____ Principal Signature	_____ Surety Signature
_____ Date	_____ Date
_____ Printed Name	_____ Printed Name
_____ Title	_____ Title

Local office/agent of Surety Company:
Name _____ Telephone _____
Address _____

PUBLIC WORKS PAYMENT BOND

to the City of Lakewood, WA

Bond No. _____

The City of Lakewood, Washington, (City) has awarded to _____ (Principal), a Contract for the construction of the project designated as Farwest DR SW Safe Routes to Schools, Project No. 302.0164, in Lakewood, Washington (Contract), and said Principal is required under the terms of that Contract to furnish a payment bond in accord with Title 39.08 Revised Code of Washington (RCW) and (where applicable) 60.28 RCW.

The Principal and _____ (Surety), a corporation organized under the laws of the State of _____ and licensed to do business in the State of Washington as surety and named in the current list of "Surety Companies Acceptable in Federal Bonds" as published in the Federal Register by the Audit Staff Bureau of Accounts, U.S. Treasury Dept., are jointly and severally held and firmly bound to the City of Lakewood, in the sum of _____ US Dollars (\$ _____) Total Contract Amount, subject to the provisions herein.

This statutory payment bond shall become null and void, if and when the Principal, its heirs, executors, administrators, successors, or assigns shall pay all persons in accordance with RCW Titles 60.28, 39.08, and 39.12 including all workers, laborers, mechanics, subcontractors, lower tier subcontractors, and material suppliers, and all persons who shall supply such contractor or subcontractor with provisions and supplies for the carrying on of such work, and all taxes incurred on said Contract under Title 50 and 51 RCW and all taxes imposed on the Principal under Title 82 RCW; and if such payment obligations have not been fulfilled, this bond shall remain in full force and effect.

The Surety agrees to indemnify, defend, and protect the City of Lakewood against any claim of direct or indirect loss resulting from the failure of the Principal, its heirs, executors, administrators, successors, or assigns, (or the subcontractors or lower tier subcontractors of the Principal) to pay all laborers, mechanics, subcontractors, lower tier subcontractors material persons, and all persons who shall supply such contractor or subcontractors with provisions and supplies for the carrying on of such work.

The Surety for value received agrees that no change, extension of time, alteration or addition to the terms of the Contract, the specifications accompanying the Contract, or to the work to be performed under the Contract shall in any way affect its obligation on this bond, except as provided herein, and waives notice of any change, extension of time, alteration or addition to the terms of the Contract or the work performed. The Surety agrees that modifications and changes to the terms and conditions of the Contract that increase the total amount to be paid the Principal shall automatically increase the obligation of the Surety on this bond and notice to Surety is not required for such increased obligation.

This bond may be executed in two (2) original counterparts, and shall be signed by the parties' duly authorized officers. This bond will only be accepted if it is accompanied by a fully executed and original power of attorney for the officer executing on behalf of the surety.

The Surety agrees to be bound by the laws of the state of Washington and subjected to the jurisdiction of the state of Washington.

PRINCIPAL

SURETY

Principal Signature

Date

Surety Signature

Date

Printed Name

Printed Name

Title

Title

Local office/agent of Surety Company:

Name _____

Telephone _____

Address _____

CITY OF LAKEWOOD

E-VERIFY REQUIREMENTS FOR CONTRACTORS

By Ordinance, the City of Lakewood requires that all contractors who enter into agreements to provide services or products to the City use the Department of Homeland Security's E-Verify system when hiring new employees for the term of the contract.

E-Verify is an electronic system designed to verify the documentation of job applicants. It is run by the Department of Homeland Security.

Who is affected?

- All contractors doing business for the City of Lakewood. There is no minimum dollar value for contracts affected.
- All subcontractors employed by the general contractor on these contracts.

Are there exceptions?

- Contracts for "Commercial-Off-The-Shelf" items are exempted from this requirement.
- Individuals, Companies, or other organizations who do not have employees.

How long must the contractor comply with the E-Verify system?

- For at least the term of the contract.

Are there other stipulations?

- E-Verify must be used ONLY for NEW HIRES during the term of the contract. It is NOT to be used for EXISTING EMPLOYEES.
- E-Verify must be used to verify the documentation of ANY new employee during the term of the contract, not just those directly or indirectly working on deliverables related to the City of Lakewood contract.

How will the City of Lakewood check for compliance?

- All contractors will retain a copy of the E-Verify Memorandum of Understanding that they execute with the Department of Homeland Security AND
- Sign and submit to the City an Affidavit of Compliance with their signed contract.
- All General Contractors will be required to have their subcontractors sign an Affidavit of Compliance and retain that Affidavit for 4 years after end of the contract.
- The City of Lakewood has the right to audit the Contractor's compliance with the E-Verify Ordinance.

Further information on E-Verify can be found at the following website:

<http://www.uscis.gov/e-verify>

If you have questions about the City's E-Verify Ordinance, please contact the City of Lakewood's legal department prior to contracting with the City.

CITY OF LAKEWOOD

**AFFIDAVIT OF COMPLIANCE WITH LAKEWOOD MUNICIPAL CODE 1.42
“E-VERIFY“**

As the person duly authorized to enter into such commitment for

_____,
(Company or Organization Name)

I hereby certify that the Company or Organization named herein will

(check one box below)

- Be in compliance with all of the requirements of City of Lakewood Municipal Code Chapter 1.42 for the duration of the contract entered into between the City of Lakewood and the Company or Organization.

OR

- Hire no employees for the term of the contract between the City and the Company or Organization.

NAME

TITLE

DATE

Part II
Federal Aid Contract Provisions

**REQUIRED CONTRACT PROVISIONS
FEDERAL-AID CONSTRUCTION CONTRACTS**

- I. General
- II. Nondiscrimination
- III. Non-segregated Facilities
- IV. Davis-Bacon and Related Act Provisions
- V. Contract Work Hours and Safety Standards Act Provisions
- VI. Subletting or Assigning the Contract
- VII. Safety: Accident Prevention
- VIII. False Statements Concerning Highway Projects
- IX. Implementation of Clean Air Act and Federal Water Pollution Control Act
- X. Certification Regarding Debarment, Suspension, Ineligibility and Voluntary Exclusion
- XI. Certification Regarding Use of Contract Funds for Lobbying
- XII. Use of United States-Flag Vessels:

ATTACHMENTS

A. Employment and Materials Preference for Appalachian Development Highway System or Appalachian Local Access Road Contracts (included in Appalachian contracts only)

I. GENERAL

1. Form FHWA-1273 must be physically incorporated in each construction contract funded under title 23, United States Code, as required in 23 CFR 633.102(b) (excluding emergency contracts solely intended for debris removal). The contractor (or subcontractor) must insert this form in each subcontract and further require its inclusion in all lower tier subcontracts (excluding purchase orders, rental agreements and other agreements for supplies or services). 23 CFR 633.102(e).

The applicable requirements of Form FHWA-1273 are incorporated by reference for work done under any purchase order, rental agreement or agreement for other services. The prime contractor shall be responsible for compliance by any subcontractor, lower-tier subcontractor or service provider. 23 CFR 633.102(e).

Form FHWA-1273 must be included in all Federal-aid design-build contracts, in all subcontracts and in lower tier subcontracts (excluding subcontracts for design services, purchase orders, rental agreements and other agreements for supplies or services) in accordance with 23 CFR 633.102. The design-builder shall be responsible for compliance by any subcontractor, lower-tier subcontractor or service provider.

Contracting agencies may reference Form FHWA-1273 in solicitation-for-bids or request-for-proposals documents, however, the Form FHWA-1273 must be physically incorporated (not referenced) in all contracts, subcontracts and lower-tier subcontracts (excluding purchase orders, rental agreements and other agreements for supplies or services related to a construction contract). 23 CFR 633.102(b).

2. Subject to the applicability criteria noted in the following sections, these contract provisions shall apply to all work

performed on the contract by the contractor's own organization and with the assistance of workers under the contractor's immediate superintendence and to all work performed on the contract by piecework, station work, or by subcontract. 23 CFR 633.102(d).

3. A breach of any of the stipulations contained in these Required Contract Provisions may be sufficient grounds for withholding of progress payments, withholding of final payment, termination of the contract, suspension / debarment or any other action determined to be appropriate by the contracting agency and FHWA.

4. Selection of Labor: During the performance of this contract, the contractor shall not use convict labor for any purpose within the limits of a construction project on a Federal-aid highway unless it is labor performed by convicts who are on parole, supervised release, or probation. 23 U.S.C. 114(b). The term Federal-aid highway does not include roadways functionally classified as local roads or rural minor collectors. 23 U.S.C. 101(a).

II. NONDISCRIMINATION (23 CFR 230.107(a); 23 CFR Part 230, Subpart A, Appendix A; EO 11246)

The provisions of this section related to 23 CFR Part 230, Subpart A, Appendix A are applicable to all Federal-aid construction contracts and to all related construction subcontracts of \$10,000 or more. The provisions of 23 CFR Part 230 are not applicable to material supply, engineering, or architectural service contracts.

In addition, the contractor and all subcontractors must comply with the following policies: Executive Order 11246, 41 CFR Part 60, 29 CFR Parts 1625-1627, 23 U.S.C. 140, Section 504 of the Rehabilitation Act of 1973, as amended (29 U.S.C. 794), Title VI of the Civil Rights Act of 1964, as amended (42 U.S.C. 2000d et seq.), and related regulations including 49 CFR Parts 21, 26, and 27; and 23 CFR Parts 200, 230, and 633.

The contractor and all subcontractors must comply with: the requirements of the Equal Opportunity Clause in 41 CFR 60-1.4(b) and, for all construction contracts exceeding \$10,000, the Standard Federal Equal Employment Opportunity Construction Contract Specifications in 41 CFR 60-4.3.

Note: The U.S. Department of Labor has exclusive authority to determine compliance with Executive Order 11246 and the policies of the Secretary of Labor including 41 CFR Part 60, and 29 CFR Parts 1625-1627. The contracting agency and the FHWA have the authority and the responsibility to ensure compliance with 23 U.S.C. 140, Section 504 of the Rehabilitation Act of 1973, as amended (29 U.S.C. 794), and Title VI of the Civil Rights Act of 1964, as amended (42 U.S.C. 2000d et seq.), and related regulations including 49 CFR Parts 21, 26, and 27; and 23 CFR Parts 200, 230, and 633.

The following provision is adopted from 23 CFR Part 230, Subpart A, Appendix A, with appropriate revisions to conform to the U.S. Department of Labor (US DOL) and FHWA requirements.

1. Equal Employment Opportunity: Equal Employment Opportunity (EEO) requirements not to discriminate and to take affirmative action to assure equal opportunity as set forth under laws, executive orders, rules, regulations (see 28 CFR Part 35, 29 CFR Part 1630, 29 CFR Parts 1625-1627, 41 CFR Part 60 and 49 CFR Part 27) and orders of the Secretary of Labor as modified by the provisions prescribed herein, and imposed pursuant to 23 U.S.C. 140, shall constitute the EEO and specific affirmative action standards for the contractor's project activities under this contract. The provisions of the Americans with Disabilities Act of 1990 (42 U.S.C. 12101 et seq.) set forth under 28 CFR Part 35 and 29 CFR Part 1630 are incorporated by reference in this contract. In the execution of this contract, the contractor agrees to comply with the following minimum specific requirement activities of EEO:

a. The contractor will work with the contracting agency and the Federal Government to ensure that it has made every good faith effort to provide equal opportunity with respect to all of its terms and conditions of employment and in their review of activities under the contract. 23 CFR 230.409 (g)(4) & (5).

b. The contractor will accept as its operating policy the following statement:

"It is the policy of this Company to assure that applicants are employed, and that employees are treated during employment, without regard to their race, religion, sex, sexual orientation, gender identity, color, national origin, age or disability. Such action shall include: employment, upgrading, demotion, or transfer; recruitment or recruitment advertising; layoff or termination; rates of pay or other forms of compensation; and selection for training, including apprenticeship, pre-apprenticeship, and/or on-the-job training."

2. EEO Officer: The contractor will designate and make known to the contracting officers an EEO Officer who will have the responsibility for and must be capable of effectively administering and promoting an active EEO program and who must be assigned adequate authority and responsibility to do so.

3. Dissemination of Policy: All members of the contractor's staff who are authorized to hire, supervise, promote, and discharge employees, or who recommend such action or are substantially involved in such action, will be made fully cognizant of and will implement the contractor's EEO policy and contractual responsibilities to provide EEO in each grade and classification of employment. To ensure that the above agreement will be met, the following actions will be taken as a minimum:

a. Periodic meetings of supervisory and personnel office employees will be conducted before the start of work and then not less often than once every six months, at which time the contractor's EEO policy and its implementation will be reviewed and explained. The meetings will be conducted by the EEO Officer or other knowledgeable company official.

b. All new supervisory or personnel office employees will be given a thorough indoctrination by the EEO Officer, covering all major aspects of the contractor's EEO obligations within thirty days following their reporting for duty with the contractor.

c. All personnel who are engaged in direct recruitment for the project will be instructed by the EEO Officer in the contractor's procedures for locating and hiring minorities and women.

d. Notices and posters setting forth the contractor's EEO policy will be placed in areas readily accessible to employees, applicants for employment and potential employees.

e. The contractor's EEO policy and the procedures to implement such policy will be brought to the attention of employees by means of meetings, employee handbooks, or other appropriate means.

4. Recruitment: When advertising for employees, the contractor will include in all advertisements for employees the notation: "An Equal Opportunity Employer." All such advertisements will be placed in publications having a large circulation among minorities and women in the area from which the project work force would normally be derived.

a. The contractor will, unless precluded by a valid bargaining agreement, conduct systematic and direct recruitment through public and private employee referral sources likely to yield qualified minorities and women. To meet this requirement, the contractor will identify sources of potential minority group employees and establish with such identified sources procedures whereby minority and women applicants may be referred to the contractor for employment consideration.

b. In the event the contractor has a valid bargaining agreement providing for exclusive hiring hall referrals, the contractor is expected to observe the provisions of that agreement to the extent that the system meets the contractor's compliance with EEO contract provisions. Where implementation of such an agreement has the effect of discriminating against minorities or women, or obligates the contractor to do the same, such implementation violates Federal nondiscrimination provisions.

c. The contractor will encourage its present employees to refer minorities and women as applicants for employment. Information and procedures with regard to referring such applicants will be discussed with employees.

5. Personnel Actions: Wages, working conditions, and employee benefits shall be established and administered, and personnel actions of every type, including hiring, upgrading, promotion, transfer, demotion, layoff, and termination, shall be taken without regard to race, color, religion, sex, sexual orientation, gender identity, national origin, age or disability. The following procedures shall be followed:

a. The contractor will conduct periodic inspections of project sites to ensure that working conditions and employee facilities do not indicate discriminatory treatment of project site personnel.

b. The contractor will periodically evaluate the spread of wages paid within each classification to determine any evidence of discriminatory wage practices.

c. The contractor will periodically review selected personnel actions in depth to determine whether there is evidence of discrimination. Where evidence is found, the contractor will promptly take corrective action. If the review indicates that the discrimination may extend beyond the actions reviewed, such corrective action shall include all affected persons.

d. The contractor will promptly investigate all complaints of alleged discrimination made to the contractor in connection with its obligations under this contract, will attempt to resolve such complaints, and will take appropriate corrective action

within a reasonable time. If the investigation indicates that the discrimination may affect persons other than the complainant, such corrective action shall include such other persons. Upon completion of each investigation, the contractor will inform every complainant of all of their avenues of appeal.

6. Training and Promotion:

a. The contractor will assist in locating, qualifying, and increasing the skills of minorities and women who are applicants for employment or current employees. Such efforts should be aimed at developing full journey level status employees in the type of trade or job classification involved.

b. Consistent with the contractor's work force requirements and as permissible under Federal and State regulations, the contractor shall make full use of training programs (i.e., apprenticeship and on-the-job training programs for the geographical area of contract performance). In the event a special provision for training is provided under this contract, this subparagraph will be superseded as indicated in the special provision. The contracting agency may reserve training positions for persons who receive welfare assistance in accordance with 23 U.S.C. 140(a).

c. The contractor will advise employees and applicants for employment of available training programs and entrance requirements for each.

d. The contractor will periodically review the training and promotion potential of employees who are minorities and women and will encourage eligible employees to apply for such training and promotion.

7. Unions: If the contractor relies in whole or in part upon unions as a source of employees, the contractor will use good faith efforts to obtain the cooperation of such unions to increase opportunities for minorities and women. 23 CFR 230.409. Actions by the contractor, either directly or through a contractor's association acting as agent, will include the procedures set forth below:

a. The contractor will use good faith efforts to develop, in cooperation with the unions, joint training programs aimed toward qualifying more minorities and women for membership in the unions and increasing the skills of minorities and women so that they may qualify for higher paying employment.

b. The contractor will use good faith efforts to incorporate an EEO clause into each union agreement to the end that such union will be contractually bound to refer applicants without regard to their race, color, religion, sex, sexual orientation, gender identity, national origin, age, or disability.

c. The contractor is to obtain information as to the referral practices and policies of the labor union except that to the extent such information is within the exclusive possession of the labor union and such labor union refuses to furnish such information to the contractor, the contractor shall so certify to the contracting agency and shall set forth what efforts have been made to obtain such information.

d. In the event the union is unable to provide the contractor with a reasonable flow of referrals within the time limit set forth in the collective bargaining agreement, the contractor will, through independent recruitment efforts, fill the employment vacancies without regard to race, color, religion, sex, sexual orientation, gender identity, national origin, age, or disability; making full efforts to obtain qualified and/or qualifiable minorities and women. The failure of a union to provide

sufficient referrals (even though it is obligated to provide exclusive referrals under the terms of a collective bargaining agreement) does not relieve the contractor from the requirements of this paragraph. In the event the union referral practice prevents the contractor from meeting the obligations pursuant to Executive Order 11246, as amended, and these special provisions, such contractor shall immediately notify the contracting agency.

8. Reasonable Accommodation for Applicants / Employees with Disabilities: The contractor must be familiar with the requirements for and comply with the Americans with Disabilities Act and all rules and regulations established thereunder. Employers must provide reasonable accommodation in all employment activities unless to do so would cause an undue hardship.

9. Selection of Subcontractors, Procurement of Materials and Leasing of Equipment: The contractor shall not discriminate on the grounds of race, color, religion, sex, sexual orientation, gender identity, national origin, age, or disability in the selection and retention of subcontractors, including procurement of materials and leases of equipment. The contractor shall take all necessary and reasonable steps to ensure nondiscrimination in the administration of this contract.

a. The contractor shall notify all potential subcontractors, suppliers, and lessors of their EEO obligations under this contract.

b. The contractor will use good faith efforts to ensure subcontractor compliance with their EEO obligations.

10. Assurances Required:

a. The requirements of 49 CFR Part 26 and the State DOT's FHWA-approved Disadvantaged Business Enterprise (DBE) program are incorporated by reference.

b. The contractor, subrecipient or subcontractor shall not discriminate on the basis of race, color, national origin, or sex in the performance of this contract. The contractor shall carry out applicable requirements of 49 CFR part 26 in the award and administration of DOT-assisted contracts. Failure by the contractor to carry out these requirements is a material breach of this contract, which may result in the termination of this contract or such other remedy as the recipient deems appropriate, which may include, but is not limited to:

- (1) Withholding monthly progress payments;
- (2) Assessing sanctions;
- (3) Liquidated damages; and/or
- (4) Disqualifying the contractor from future bidding as non-responsible.

c. The Title VI and nondiscrimination provisions of U.S. DOT Order 1050.2A at Appendixes A and E are incorporated by reference. 49 CFR Part 21.

11. Records and Reports: The contractor shall keep such records as necessary to document compliance with the EEO requirements. Such records shall be retained for a period of three years following the date of the final payment to the contractor for all contract work and shall be available at reasonable times and places for inspection by authorized representatives of the contracting agency and the FHWA.

a. The records kept by the contractor shall document the following:

(1) The number and work hours of minority and non-minority group members and women employed in each work classification on the project;

(2) The progress and efforts being made in cooperation with unions, when applicable, to increase employment opportunities for minorities and women; and

(3) The progress and efforts being made in locating, hiring, training, qualifying, and upgrading minorities and women.

b. The contractors and subcontractors will submit an annual report to the contracting agency each July for the duration of the project indicating the number of minority, women, and non-minority group employees currently engaged in each work classification required by the contract work. This information is to be reported on [Form FHWA-1391](#). The staffing data should represent the project work force on board in all or any part of the last payroll period preceding the end of July. If on-the-job training is being required by special provision, the contractor will be required to collect and report training data. The employment data should reflect the work force on board during all or any part of the last payroll period preceding the end of July.

III. NONSEGREGATED FACILITIES

This provision is applicable to all Federal-aid construction contracts and to all related construction subcontracts of more than \$10,000. 41 CFR 60-1.5.

As prescribed by 41 CFR 60-1.8, the contractor must ensure that facilities provided for employees are provided in such a manner that segregation on the basis of race, color, religion, sex, sexual orientation, gender identity, or national origin cannot result. The contractor may neither require such segregated use by written or oral policies nor tolerate such use by employee custom. The contractor's obligation extends further to ensure that its employees are not assigned to perform their services at any location under the contractor's control where the facilities are segregated. The term "facilities" includes waiting rooms, work areas, restaurants and other eating areas, time clocks, restrooms, washrooms, locker rooms and other storage or dressing areas, parking lots, drinking fountains, recreation or entertainment areas, transportation, and housing provided for employees. The contractor shall provide separate or single-user restrooms and necessary dressing or sleeping areas to assure privacy between sexes.

IV. DAVIS-BACON AND RELATED ACT PROVISIONS

This section is applicable to all Federal-aid construction projects exceeding \$2,000 and to all related subcontracts and lower-tier subcontracts (regardless of subcontract size), in accordance with 29 CFR 5.5. The requirements apply to all projects located within the right-of-way of a roadway that is functionally classified as Federal-aid highway. 23 U.S.C. 113. This excludes roadways functionally classified as local roads or rural minor collectors, which are exempt. 23 U.S.C. 101. Where applicable law requires that projects be treated as a project on a Federal-aid highway, the provisions of this subpart will apply regardless of the location of the project. Examples include: Surface Transportation Block Grant Program projects funded under 23 U.S.C. 133 [excluding recreational trails projects], the Nationally Significant Freight and Highway

Projects funded under 23 U.S.C. 117, and National Highway Freight Program projects funded under 23 U.S.C. 167.

The following provisions are from the U.S. Department of Labor regulations in 29 CFR 5.5 "Contract provisions and related matters" with minor revisions to conform to the FHWA-1273 format and FHWA program requirements.

1. Minimum wages (29 CFR 5.5)

a. *Wage rates and fringe benefits.* All laborers and mechanics employed or working upon the site of the work (or otherwise working in construction or development of the project under a development statute), will be paid unconditionally and not less often than once a week, and without subsequent deduction or rebate on any account (except such payroll deductions as are permitted by regulations issued by the Secretary of Labor under the Copeland Act ([29 CFR part 3](#))), the full amount of basic hourly wages and bona fide fringe benefits (or cash equivalents thereof) due at time of payment computed at rates not less than those contained in the wage determination of the Secretary of Labor which is attached hereto and made a part hereof, regardless of any contractual relationship which may be alleged to exist between the contractor and such laborers and mechanics. As provided in paragraphs (d) and (e) of 29 CFR 5.5, the appropriate wage determinations are effective by operation of law even if they have not been attached to the contract. Contributions made or costs reasonably anticipated for bona fide fringe benefits under the Davis-Bacon Act ([40 U.S.C. 3141\(2\)\(B\)](#)) on behalf of laborers or mechanics are considered wages paid to such laborers or mechanics, subject to the provisions of paragraph 1.e. of this section; also, regular contributions made or costs incurred for more than a weekly period (but not less often than quarterly) under plans, funds, or programs which cover the particular weekly period, are deemed to be constructively made or incurred during such weekly period. Such laborers and mechanics must be paid the appropriate wage rate and fringe benefits on the wage determination for the classification(s) of work actually performed, without regard to skill, except as provided in paragraph 4. of this section. Laborers or mechanics performing work in more than one classification may be compensated at the rate specified for each classification for the time actually worked therein: *Provided*, That the employer's payroll records accurately set forth the time spent in each classification in which work is performed. The wage determination (including any additional classifications and wage rates conformed under paragraph 1.c. of this section) and the Davis-Bacon poster (WH-1321) must be posted at all times by the contractor and its subcontractors at the site of the work in a prominent and accessible place where it can be easily seen by the workers.

b. *Frequently recurring classifications.* (1) In addition to wage and fringe benefit rates that have been determined to be prevailing under the procedures set forth in [29 CFR part 1](#), a wage determination may contain, pursuant to § 1.3(f), wage and fringe benefit rates for classifications of laborers and mechanics for which conformance requests are regularly submitted pursuant to paragraph 1.c. of this section, provided that:

(i) The work performed by the classification is not performed by a classification in the wage determination for which a prevailing wage rate has been determined;

(ii) The classification is used in the area by the construction industry; and

(iii) The wage rate for the classification bears a reasonable relationship to the prevailing wage rates contained in the wage determination.

(2) The Administrator will establish wage rates for such classifications in accordance with paragraph 1.c.(1)(iii) of this section. Work performed in such a classification must be paid at no less than the wage and fringe benefit rate listed on the wage determination for such classification.

c. *Conformance.* (1) The contracting officer must require that any class of laborers or mechanics, including helpers, which is not listed in the wage determination and which is to be employed under the contract be classified in conformance with the wage determination. Conformance of an additional classification and wage rate and fringe benefits is appropriate only when the following criteria have been met:

(i) The work to be performed by the classification requested is not performed by a classification in the wage determination; and

(ii) The classification is used in the area by the construction industry; and

(iii) The proposed wage rate, including any bona fide fringe benefits, bears a reasonable relationship to the wage rates contained in the wage determination.

(2) The conformance process may not be used to split, subdivide, or otherwise avoid application of classifications listed in the wage determination.

(3) If the contractor and the laborers and mechanics to be employed in the classification (if known), or their representatives, and the contracting officer agree on the classification and wage rate (including the amount designated for fringe benefits where appropriate), a report of the action taken will be sent by the contracting officer by email to DBAconformance@dol.gov. The Administrator, or an authorized representative, will approve, modify, or disapprove every additional classification action within 30 days of receipt and so advise the contracting officer or will notify the contracting officer within the 30-day period that additional time is necessary.

(4) In the event the contractor, the laborers or mechanics to be employed in the classification or their representatives, and the contracting officer do not agree on the proposed classification and wage rate (including the amount designated for fringe benefits, where appropriate), the contracting officer will, by email to DBAconformance@dol.gov, refer the questions, including the views of all interested parties and the recommendation of the contracting officer, to the Administrator for determination. The Administrator, or an authorized representative, will issue a determination within 30 days of receipt and so advise the contracting officer or will notify the contracting officer within the 30-day period that additional time is necessary.

(5) The contracting officer must promptly notify the contractor of the action taken by the Wage and Hour Division

under paragraphs 1.c.(3) and (4) of this section. The contractor must furnish a written copy of such determination to each affected worker or it must be posted as a part of the wage determination. The wage rate (including fringe benefits where appropriate) determined pursuant to paragraph 1.c.(3) or (4) of this section must be paid to all workers performing work in the classification under this contract from the first day on which work is performed in the classification.

d. *Fringe benefits not expressed as an hourly rate.* Whenever the minimum wage rate prescribed in the contract for a class of laborers or mechanics includes a fringe benefit which is not expressed as an hourly rate, the contractor may either pay the benefit as stated in the wage determination or may pay another bona fide fringe benefit or an hourly cash equivalent thereof.

e. *Unfunded plans.* If the contractor does not make payments to a trustee or other third person, the contractor may consider as part of the wages of any laborer or mechanic the amount of any costs reasonably anticipated in providing bona fide fringe benefits under a plan or program, *Provided*, That the Secretary of Labor has found, upon the written request of the contractor, in accordance with the criteria set forth in § 5.28, that the applicable standards of the Davis-Bacon Act have been met. The Secretary of Labor may require the contractor to set aside in a separate account assets for the meeting of obligations under the plan or program.

f. *Interest.* In the event of a failure to pay all or part of the wages required by the contract, the contractor will be required to pay interest on any underpayment of wages.

2. Withholding (29 CFR 5.5)

a. *Withholding requirements.* The contracting agency may, upon its own action, or must, upon written request of an authorized representative of the Department of Labor, withhold or cause to be withheld from the contractor so much of the accrued payments or advances as may be considered necessary to satisfy the liabilities of the prime contractor or any subcontractor for the full amount of wages and monetary relief, including interest, required by the clauses set forth in this section for violations of this contract, or to satisfy any such liabilities required by any other Federal contract, or federally assisted contract subject to Davis-Bacon labor standards, that is held by the same prime contractor (as defined in § 5.2). The necessary funds may be withheld from the contractor under this contract, any other Federal contract with the same prime contractor, or any other federally assisted contract that is subject to Davis-Bacon labor standards requirements and is held by the same prime contractor, regardless of whether the other contract was awarded or assisted by the same agency, and such funds may be used to satisfy the contractor liability for which the funds were withheld. In the event of a contractor's failure to pay any laborer or mechanic, including any apprentice or helper working on the site of the work all or part of the wages required by the contract, or upon the contractor's failure to submit the required records as discussed in paragraph 3.d. of this section, the contracting agency may on its own initiative and after written notice to the contractor, take such action as may be necessary to cause the suspension of any further payment, advance, or guarantee of funds until such violations have ceased.

b. *Priority to withheld funds.* The Department has priority to funds withheld or to be withheld in accordance with paragraph

2.a. of this section or Section V, paragraph 3.a., or both, over claims to those funds by:

- (1) A contractor's surety(ies), including without limitation performance bond sureties and payment bond sureties;
- (2) A contracting agency for its procurement costs;
- (3) A trustee(s) (either a court-appointed trustee or a U.S. trustee, or both) in bankruptcy of a contractor, or a contractor's bankruptcy estate;
- (4) A contractor's assignee(s);
- (5) A contractor's successor(s); or
- (6) A claim asserted under the Prompt Payment Act, [31 U.S.C. 3901–3907](#).

3. Records and certified payrolls (29 CFR 5.5)

a. *Basic record requirements (1) Length of record retention.* All regular payrolls and other basic records must be maintained by the contractor and any subcontractor during the course of the work and preserved for all laborers and mechanics working at the site of the work (or otherwise working in construction or development of the project under a development statute) for a period of at least 3 years after all the work on the prime contract is completed.

(2) *Information required.* Such records must contain the name; Social Security number; last known address, telephone number, and email address of each such worker; each worker's correct classification(s) of work actually performed; hourly rates of wages paid (including rates of contributions or costs anticipated for bona fide fringe benefits or cash equivalents thereof of the types described in [40 U.S.C. 3141\(2\)\(B\)](#) of the Davis-Bacon Act); daily and weekly number of hours actually worked in total and on each covered contract; deductions made; and actual wages paid.

(3) *Additional records relating to fringe benefits.* Whenever the Secretary of Labor has found under paragraph 1.e. of this section that the wages of any laborer or mechanic include the amount of any costs reasonably anticipated in providing benefits under a plan or program described in [40 U.S.C. 3141\(2\)\(B\)](#) of the Davis-Bacon Act, the contractor must maintain records which show that the commitment to provide such benefits is enforceable, that the plan or program is financially responsible, and that the plan or program has been communicated in writing to the laborers or mechanics affected, and records which show the costs anticipated or the actual cost incurred in providing such benefits.

(4) *Additional records relating to apprenticeship.* Contractors with apprentices working under approved programs must maintain written evidence of the registration of apprenticeship programs, the registration of the apprentices, and the ratios and wage rates prescribed in the applicable programs.

b. *Certified payroll requirements (1) Frequency and method of submission.* The contractor or subcontractor must submit weekly, for each week in which any DBA- or Related Acts-covered work is performed, certified payrolls to the contracting

agency. The prime contractor is responsible for the submission of all certified payrolls by all subcontractors. A contracting agency or prime contractor may permit or require contractors to submit certified payrolls through an electronic system, as long as the electronic system requires a legally valid electronic signature; the system allows the contractor, the contracting agency, and the Department of Labor to access the certified payrolls upon request for at least 3 years after the work on the prime contract has been completed; and the contracting agency or prime contractor permits other methods of submission in situations where the contractor is unable or limited in its ability to use or access the electronic system.

(2) *Information required.* The certified payrolls submitted must set out accurately and completely all of the information required to be maintained under paragraph 3.a.(2) of this section, except that full Social Security numbers and last known addresses, telephone numbers, and email addresses must not be included on weekly transmittals. Instead, the certified payrolls need only include an individually identifying number for each worker (e.g., the last four digits of the worker's Social Security number). The required weekly certified payroll information may be submitted using Optional Form WH-347 or in any other format desired. Optional Form WH-347 is available for this purpose from the Wage and Hour Division website at <https://www.dol.gov/sites/dolgov/files/WHD/legacy/files/wh347.pdf> or its successor website. It is not a violation of this section for a prime contractor to require a subcontractor to provide full Social Security numbers and last known addresses, telephone numbers, and email addresses to the prime contractor for its own records, without weekly submission by the subcontractor to the contracting agency.

(3) *Statement of Compliance.* Each certified payroll submitted must be accompanied by a "Statement of Compliance," signed by the contractor or subcontractor, or the contractor's or subcontractor's agent who pays or supervises the payment of the persons working on the contract, and must certify the following:

(i) That the certified payroll for the payroll period contains the information required to be provided under paragraph 3.b. of this section, the appropriate information and basic records are being maintained under paragraph 3.a. of this section, and such information and records are correct and complete;

(ii) That each laborer or mechanic (including each helper and apprentice) working on the contract during the payroll period has been paid the full weekly wages earned, without rebate, either directly or indirectly, and that no deductions have been made either directly or indirectly from the full wages earned, other than permissible deductions as set forth in [29 CFR part 3](#); and

(iii) That each laborer or mechanic has been paid not less than the applicable wage rates and fringe benefits or cash equivalents for the classification(s) of work actually performed, as specified in the applicable wage determination incorporated into the contract.

(4) *Use of Optional Form WH-347.* The weekly submission of a properly executed certification set forth on the reverse side of Optional Form WH-347 will satisfy the requirement for submission of the "Statement of Compliance" required by paragraph 3.b.(3) of this section.

(5) *Signature.* The signature by the contractor, subcontractor, or the contractor's or subcontractor's agent must be an original handwritten signature or a legally valid electronic signature.

(6) *Falsification.* The falsification of any of the above certifications may subject the contractor or subcontractor to civil or criminal prosecution under [18 U.S.C. 1001](#) and [31 U.S.C. 3729](#).

(7) *Length of certified payroll retention.* The contractor or subcontractor must preserve all certified payrolls during the course of the work and for a period of 3 years after all the work on the prime contract is completed.

c. *Contracts, subcontracts, and related documents.* The contractor or subcontractor must maintain this contract or subcontract and related documents including, without limitation, bids, proposals, amendments, modifications, and extensions. The contractor or subcontractor must preserve these contracts, subcontracts, and related documents during the course of the work and for a period of 3 years after all the work on the prime contract is completed.

d. *Required disclosures and access (1) Required record disclosures and access to workers.* The contractor or subcontractor must make the records required under paragraphs 3.a. through 3.c. of this section, and any other documents that the contracting agency, the State DOT, the FHWA, or the Department of Labor deems necessary to determine compliance with the labor standards provisions of any of the applicable statutes referenced by § 5.1, available for inspection, copying, or transcription by authorized representatives of the contracting agency, the State DOT, the FHWA, or the Department of Labor, and must permit such representatives to interview workers during working hours on the job.

(2) *Sanctions for non-compliance with records and worker access requirements.* If the contractor or subcontractor fails to submit the required records or to make them available, or refuses to permit worker interviews during working hours on the job, the Federal agency may, after written notice to the contractor, sponsor, applicant, owner, or other entity, as the case may be, that maintains such records or that employs such workers, take such action as may be necessary to cause the suspension of any further payment, advance, or guarantee of funds. Furthermore, failure to submit the required records upon request or to make such records available, or to permit worker interviews during working hours on the job, may be grounds for debarment action pursuant to § 5.12. In addition, any contractor or other person that fails to submit the required records or make those records available to WHD within the time WHD requests that the records be produced will be precluded from introducing as evidence in an administrative proceeding under [29 CFR part 6](#) any of the required records that were not provided or made available to WHD. WHD will take into consideration a reasonable request from the contractor or person for an extension of the time for submission of records. WHD will determine the reasonableness of the request and may consider, among other things, the location of the records and the volume of production.

(3) *Required information disclosures.* Contractors and subcontractors must maintain the full Social Security number and last known address, telephone number, and email address

of each covered worker, and must provide them upon request to the contracting agency, the State DOT, the FHWA, the contractor, or the Wage and Hour Division of the Department of Labor for purposes of an investigation or other compliance action.

4. Apprentices and equal employment opportunity (29 CFR 5.5)

a. *Apprentices (1) Rate of pay.* Apprentices will be permitted to work at less than the predetermined rate for the work they perform when they are employed pursuant to and individually registered in a bona fide apprenticeship program registered with the U.S. Department of Labor, Employment and Training Administration, Office of Apprenticeship (OA), or with a State Apprenticeship Agency recognized by the OA. A person who is not individually registered in the program, but who has been certified by the OA or a State Apprenticeship Agency (where appropriate) to be eligible for probationary employment as an apprentice, will be permitted to work at less than the predetermined rate for the work they perform in the first 90 days of probationary employment as an apprentice in such a program. In the event the OA or a State Apprenticeship Agency recognized by the OA withdraws approval of an apprenticeship program, the contractor will no longer be permitted to use apprentices at less than the applicable predetermined rate for the work performed until an acceptable program is approved.

(2) *Fringe benefits.* Apprentices must be paid fringe benefits in accordance with the provisions of the apprenticeship program. If the apprenticeship program does not specify fringe benefits, apprentices must be paid the full amount of fringe benefits listed on the wage determination for the applicable classification. If the Administrator determines that a different practice prevails for the applicable apprentice classification, fringe benefits must be paid in accordance with that determination.

(3) *Apprenticeship ratio.* The allowable ratio of apprentices to journeyworkers on the job site in any craft classification must not be greater than the ratio permitted to the contractor as to the entire work force under the registered program or the ratio applicable to the locality of the project pursuant to paragraph 4.a.(4) of this section. Any worker listed on a payroll at an apprentice wage rate, who is not registered or otherwise employed as stated in paragraph 4.a.(1) of this section, must be paid not less than the applicable wage rate on the wage determination for the classification of work actually performed. In addition, any apprentice performing work on the job site in excess of the ratio permitted under this section must be paid not less than the applicable wage rate on the wage determination for the work actually performed.

(4) *Reciprocity of ratios and wage rates.* Where a contractor is performing construction on a project in a locality other than the locality in which its program is registered, the ratios and wage rates (expressed in percentages of the journeyworker's hourly rate) applicable within the locality in which the construction is being performed must be observed. If there is no applicable ratio or wage rate for the locality of the project, the ratio and wage rate specified in the contractor's registered program must be observed.

b. *Equal employment opportunity.* The use of apprentices and journeyworkers under this part must be in conformity with

the equal employment opportunity requirements of Executive Order 11246, as amended, and [29 CFR part 30](#).

c. Apprentices and Trainees (programs of the U.S. DOT).

Apprentices and trainees working under apprenticeship and skill training programs which have been certified by the Secretary of Transportation as promoting EEO in connection with Federal-aid highway construction programs are not subject to the requirements of paragraph 4 of this Section IV. 23 CFR 230.111(e)(2). The straight time hourly wage rates for apprentices and trainees under such programs will be established by the particular programs. The ratio of apprentices and trainees to journeyworkers shall not be greater than permitted by the terms of the particular program.

5. Compliance with Copeland Act requirements. The contractor shall comply with the requirements of 29 CFR part 3, which are incorporated by reference in this contract as provided in 29 CFR 5.5.

6. Subcontracts. The contractor or subcontractor must insert FHWA-1273 in any subcontracts, along with the applicable wage determination(s) and such other clauses or contract modifications as the contracting agency may by appropriate instructions require, and a clause requiring the subcontractors to include these clauses and wage determination(s) in any lower tier subcontracts. The prime contractor is responsible for the compliance by any subcontractor or lower tier subcontractor with all the contract clauses in this section. In the event of any violations of these clauses, the prime contractor and any subcontractor(s) responsible will be liable for any unpaid wages and monetary relief, including interest from the date of the underpayment or loss, due to any workers of lower-tier subcontractors, and may be subject to debarment, as appropriate. 29 CFR 5.5.

7. Contract termination: debarment. A breach of the contract clauses in 29 CFR 5.5 may be grounds for termination of the contract, and for debarment as a contractor and a subcontractor as provided in 29 CFR 5.12.

8. Compliance with Davis-Bacon and Related Act requirements. All rulings and interpretations of the Davis-Bacon and Related Acts contained in 29 CFR parts 1, 3, and 5 are herein incorporated by reference in this contract as provided in 29 CFR 5.5.

9. Disputes concerning labor standards. As provided in 29 CFR 5.5, disputes arising out of the labor standards provisions of this contract shall not be subject to the general disputes clause of this contract. Such disputes shall be resolved in accordance with the procedures of the Department of Labor set forth in 29 CFR parts 5, 6, and 7. Disputes within the meaning of this clause include disputes between the contractor (or any of its subcontractors) and the contracting agency, the U.S. Department of Labor, or the employees or their representatives.

10. Certification of eligibility. a. By entering into this contract, the contractor certifies that neither it nor any person or firm who has an interest in the contractor's firm is a person or firm ineligible to be awarded Government contracts by virtue of [40 U.S.C. 3144\(b\)](#) or § 5.12(a).

b. No part of this contract shall be subcontracted to any person or firm ineligible for award of a Government contract by virtue of [40 U.S.C. 3144\(b\)](#) or § 5.12(a).

c. The penalty for making false statements is prescribed in the U.S. Code, Title 18 Crimes and Criminal Procedure, [18 U.S.C. 1001](#).

11. Anti-retaliation. It is unlawful for any person to discharge, demote, intimidate, threaten, restrain, coerce, blacklist, harass, or in any other manner discriminate against, or to cause any person to discharge, demote, intimidate, threaten, restrain, coerce, blacklist, harass, or in any other manner discriminate against, any worker or job applicant for:

a. Notifying any contractor of any conduct which the worker reasonably believes constitutes a violation of the DBA, Related Acts, this part, or [29 CFR part 1](#) or [3](#);

b. Filing any complaint, initiating or causing to be initiated any proceeding, or otherwise asserting or seeking to assert on behalf of themselves or others any right or protection under the DBA, Related Acts, this part, or [29 CFR part 1](#) or [3](#);

c. Cooperating in any investigation or other compliance action, or testifying in any proceeding under the DBA, Related Acts, this part, or [29 CFR part 1](#) or [3](#); or

d. Informing any other person about their rights under the DBA, Related Acts, this part, or [29 CFR part 1](#) or [3](#).

V. CONTRACT WORK HOURS AND SAFETY STANDARDS ACT

Pursuant to 29 CFR 5.5(b), the following clauses apply to any Federal-aid construction contract in an amount in excess of \$100,000 and subject to the overtime provisions of the Contract Work Hours and Safety Standards Act. These clauses shall be inserted in addition to the clauses required by 29 CFR 5.5(a) or 29 CFR 4.6. As used in this paragraph, the terms laborers and mechanics include watchpersons and guards.

1. Overtime requirements. No contractor or subcontractor contracting for any part of the contract work which may require or involve the employment of laborers or mechanics shall require or permit any such laborer or mechanic in any workweek in which he or she is employed on such work to work in excess of forty hours in such workweek unless such laborer or mechanic receives compensation at a rate not less than one and one-half times the basic rate of pay for all hours worked in excess of forty hours in such workweek. 29 CFR 5.5.

2. Violation; liability for unpaid wages; liquidated damages. In the event of any violation of the clause set forth in paragraph 1. of this section the contractor and any subcontractor responsible therefor shall be liable for the unpaid wages and interest from the date of the underpayment. In addition, such contractor and subcontractor shall be liable to the United States (in the case of work done under contract for the District of Columbia or a territory, to such District or to such territory), for liquidated damages. Such liquidated damages shall be computed with respect to each individual laborer or

mechanic, including watchpersons and guards, employed in violation of the clause set forth in paragraph 1. of this section, in the sum currently provided in 29 CFR 5.5(b)(2)* for each calendar day on which such individual was required or permitted to work in excess of the standard workweek of forty hours without payment of the overtime wages required by the clause set forth in paragraph 1. of this section.

* \$31 as of January 15, 2023 (See 88 FR 88 FR 2210) as may be adjusted annually by the Department of Labor, pursuant to the Federal Civil Penalties Inflation Adjustment Act of 1990.

3. Withholding for unpaid wages and liquidated damages

a. *Withholding process.* The FHWA or the contracting agency may, upon its own action, or must, upon written request of an authorized representative of the Department of Labor, withhold or cause to be withheld from the contractor so much of the accrued payments or advances as may be considered necessary to satisfy the liabilities of the prime contractor or any subcontractor for any unpaid wages; monetary relief, including interest; and liquidated damages required by the clauses set forth in this section on this contract, any other Federal contract with the same prime contractor, or any other federally assisted contract subject to the Contract Work Hours and Safety Standards Act that is held by the same prime contractor (as defined in § 5.2). The necessary funds may be withheld from the contractor under this contract, any other Federal contract with the same prime contractor, or any other federally assisted contract that is subject to the Contract Work Hours and Safety Standards Act and is held by the same prime contractor, regardless of whether the other contract was awarded or assisted by the same agency, and such funds may be used to satisfy the contractor liability for which the funds were withheld.

b. *Priority to withheld funds.* The Department has priority to funds withheld or to be withheld in accordance with Section IV paragraph 2.a. or paragraph 3.a. of this section, or both, over claims to those funds by:

- (1) A contractor's surety(ies), including without limitation performance bond sureties and payment bond sureties;
- (2) A contracting agency for its procurement costs;
- (3) A trustee(s) (either a court-appointed trustee or a U.S. trustee, or both) in bankruptcy of a contractor, or a contractor's bankruptcy estate;
- (4) A contractor's assignee(s);
- (5) A contractor's successor(s); or
- (6) A claim asserted under the Prompt Payment Act, [31 U.S.C. 3901](#)–3907.

4. Subcontracts. The contractor or subcontractor must insert in any subcontracts the clauses set forth in paragraphs 1. through 5. of this section and a clause requiring the subcontractors to include these clauses in any lower tier subcontracts. The prime contractor is responsible for compliance by any subcontractor or lower tier subcontractor with the clauses set forth in paragraphs 1. through 5. In the

event of any violations of these clauses, the prime contractor and any subcontractor(s) responsible will be liable for any unpaid wages and monetary relief, including interest from the date of the underpayment or loss, due to any workers of lower-tier subcontractors, and associated liquidated damages and may be subject to debarment, as appropriate.

5. Anti-retaliation. It is unlawful for any person to discharge, demote, intimidate, threaten, restrain, coerce, blacklist, harass, or in any other manner discriminate against, or to cause any person to discharge, demote, intimidate, threaten, restrain, coerce, blacklist, harass, or in any other manner discriminate against, any worker or job applicant for:

a. Notifying any contractor of any conduct which the worker reasonably believes constitutes a violation of the Contract Work Hours and Safety Standards Act (CWHSSA) or its implementing regulations in this part;

b. Filing any complaint, initiating or causing to be initiated any proceeding, or otherwise asserting or seeking to assert on behalf of themselves or others any right or protection under CWHSSA or this part;

c. Cooperating in any investigation or other compliance action, or testifying in any proceeding under CWHSSA or this part; or

d. Informing any other person about their rights under CWHSSA or this part.

VI. SUBLETTING OR ASSIGNING THE CONTRACT

This provision is applicable to all Federal-aid construction contracts on the National Highway System pursuant to 23 CFR 635.116.

1. The contractor shall perform with its own organization contract work amounting to not less than 30 percent (or a greater percentage if specified elsewhere in the contract) of the total original contract price, excluding any specialty items designated by the contracting agency. Specialty items may be performed by subcontract and the amount of any such specialty items performed may be deducted from the total original contract price before computing the amount of work required to be performed by the contractor's own organization (23 CFR 635.116).

a. The term "perform work with its own organization" in paragraph 1 of Section VI refers to workers employed or leased by the prime contractor, and equipment owned or rented by the prime contractor, with or without operators. Such term does not include employees or equipment of a subcontractor or lower tier subcontractor, agents of the prime contractor, or any other assignees. The term may include payments for the costs of hiring leased employees from an employee leasing firm meeting all relevant Federal and State regulatory requirements. Leased employees may only be included in this term if the prime contractor meets all of the following conditions: (based on longstanding interpretation)

- (1) the prime contractor maintains control over the supervision of the day-to-day activities of the leased employees;
- (2) the prime contractor remains responsible for the quality of the work of the leased employees;

- (3) the prime contractor retains all power to accept or exclude individual employees from work on the project; and
- (4) the prime contractor remains ultimately responsible for the payment of predetermined minimum wages, the submission of payrolls, statements of compliance and all other Federal regulatory requirements.

b. "Specialty Items" shall be construed to be limited to work that requires highly specialized knowledge, abilities, or equipment not ordinarily available in the type of contracting organizations qualified and expected to bid or propose on the contract as a whole and in general are to be limited to minor components of the overall contract. 23 CFR 635.102.

2. Pursuant to 23 CFR 635.116(a), the contract amount upon which the requirements set forth in paragraph (1) of Section VI is computed includes the cost of material and manufactured products which are to be purchased or produced by the contractor under the contract provisions.

3. Pursuant to 23 CFR 635.116(c), the contractor shall furnish (a) a competent superintendent or supervisor who is employed by the firm, has full authority to direct performance of the work in accordance with the contract requirements, and is in charge of all construction operations (regardless of who performs the work) and (b) such other of its own organizational resources (supervision, management, and engineering services) as the contracting officer determines is necessary to assure the performance of the contract.

4. No portion of the contract shall be sublet, assigned or otherwise disposed of except with the written consent of the contracting officer, or authorized representative, and such consent when given shall not be construed to relieve the contractor of any responsibility for the fulfillment of the contract. Written consent will be given only after the contracting agency has assured that each subcontract is evidenced in writing and that it contains all pertinent provisions and requirements of the prime contract. (based on long-standing interpretation of 23 CFR 635.116).

5. The 30-percent self-performance requirement of paragraph (1) is not applicable to design-build contracts; however, contracting agencies may establish their own self-performance requirements. 23 CFR 635.116(d).

VII. SAFETY: ACCIDENT PREVENTION

This provision is applicable to all Federal-aid construction contracts and to all related subcontracts.

1. In the performance of this contract the contractor shall comply with all applicable Federal, State, and local laws governing safety, health, and sanitation (23 CFR Part 635). The contractor shall provide all safeguards, safety devices and protective equipment and take any other needed actions as it determines, or as the contracting officer may determine, to be reasonably necessary to protect the life and health of employees on the job and the safety of the public and to protect property in connection with the performance of the work covered by the contract. 23 CFR 635.108.

2. It is a condition of this contract, and shall be made a condition of each subcontract, which the contractor enters into pursuant to this contract, that the contractor and any subcontractor shall not permit any employee, in performance of the contract, to work in surroundings or under conditions which are unsanitary, hazardous or dangerous to his/her health or safety, as determined under construction safety and

health standards (29 CFR Part 1926) promulgated by the Secretary of Labor, in accordance with Section 107 of the Contract Work Hours and Safety Standards Act (40 U.S.C. 3704). 29 CFR 1926.10.

3. Pursuant to 29 CFR 1926.3, it is a condition of this contract that the Secretary of Labor or authorized representative thereof, shall have right of entry to any site of contract performance to inspect or investigate the matter of compliance with the construction safety and health standards and to carry out the duties of the Secretary under Section 107 of the Contract Work Hours and Safety Standards Act (40 U.S.C. 3704).

VIII. FALSE STATEMENTS CONCERNING HIGHWAY PROJECTS

This provision is applicable to all Federal-aid construction contracts and to all related subcontracts.

In order to assure high quality and durable construction in conformity with approved plans and specifications and a high degree of reliability on statements and representations made by engineers, contractors, suppliers, and workers on Federal-aid highway projects, it is essential that all persons concerned with the project perform their functions as carefully, thoroughly, and honestly as possible. Willful falsification, distortion, or misrepresentation with respect to any facts related to the project is a violation of Federal law. To prevent any misunderstanding regarding the seriousness of these and similar acts, Form FHWA-1022 shall be posted on each Federal-aid highway project (23 CFR Part 635) in one or more places where it is readily available to all persons concerned with the project:

18 U.S.C. 1020 reads as follows:

"Whoever, being an officer, agent, or employee of the United States, or of any State or Territory, or whoever, whether a person, association, firm, or corporation, knowingly makes any false statement, false representation, or false report as to the character, quality, quantity, or cost of the material used or to be used, or the quantity or quality of the work performed or to be performed, or the cost thereof in connection with the submission of plans, maps, specifications, contracts, or costs of construction on any highway or related project submitted for approval to the Secretary of Transportation; or

Whoever knowingly makes any false statement, false representation, false report or false claim with respect to the character, quality, quantity, or cost of any work performed or to be performed, or materials furnished or to be furnished, in connection with the construction of any highway or related project approved by the Secretary of Transportation; or

Whoever knowingly makes any false statement or false representation as to material fact in any statement, certificate, or report submitted pursuant to provisions of the Federal-aid Roads Act approved July 11, 1916, (39 Stat. 355), as amended and supplemented;

Shall be fined under this title or imprisoned not more than 5 years or both."

IX. IMPLEMENTATION OF CLEAN AIR ACT AND FEDERAL WATER POLLUTION CONTROL ACT (42 U.S.C. 7606; 2 CFR 200.88; EO 11738)

This provision is applicable to all Federal-aid construction contracts in excess of \$150,000 and to all related subcontracts. 48 CFR 2.101; 2 CFR 200.327.

By submission of this bid/proposal or the execution of this contract or subcontract, as appropriate, the bidder, proposer, Federal-aid construction contractor, subcontractor, supplier, or vendor agrees to comply with all applicable standards, orders or regulations issued pursuant to the Clean Air Act (42 U.S.C. 7401-7671q) and the Federal Water Pollution Control Act, as amended (33 U.S.C. 1251-1387). Violations must be reported to the Federal Highway Administration and the Regional Office of the Environmental Protection Agency. 2 CFR Part 200, Appendix II.

The contractor agrees to include or cause to be included the requirements of this Section in every subcontract, and further agrees to take such action as the contracting agency may direct as a means of enforcing such requirements. 2 CFR 200.327.

X. CERTIFICATION REGARDING DEBARMENT, SUSPENSION, INELIGIBILITY AND VOLUNTARY EXCLUSION

This provision is applicable to all Federal-aid construction contracts, design-build contracts, subcontracts, lower-tier subcontracts, purchase orders, lease agreements, consultant contracts or any other covered transaction requiring FHWA approval or that is estimated to cost \$25,000 or more – as defined in 2 CFR Parts 180 and 1200. 2 CFR 180.220 and 1200.220.

1. Instructions for Certification – First Tier Participants:

- a. By signing and submitting this proposal, the prospective first tier participant is providing the certification set out below.
- b. The inability of a person to provide the certification set out below will not necessarily result in denial of participation in this covered transaction. The prospective first tier participant shall submit an explanation of why it cannot provide the certification set out below. The certification or explanation will be considered in connection with the department or agency's determination whether to enter into this transaction. However, failure of the prospective first tier participant to furnish a certification or an explanation shall disqualify such a person from participation in this transaction. 2 CFR 180.320.
- c. The certification in this clause is a material representation of fact upon which reliance was placed when the contracting agency determined to enter into this transaction. If it is later determined that the prospective participant knowingly rendered an erroneous certification, in addition to other remedies available to the Federal Government, the contracting agency may terminate this transaction for cause of default. 2 CFR 180.325.
- d. The prospective first tier participant shall provide immediate written notice to the contracting agency to whom this proposal is submitted if any time the prospective first tier participant learns that its certification was erroneous when submitted or has become erroneous by reason of changed circumstances. 2 CFR 180.345 and 180.350.

e. The terms "covered transaction," "debarred," "suspended," "ineligible," "participant," "person," "principal," and "voluntarily excluded," as used in this clause, are defined in 2 CFR Parts 180, Subpart I, 180.900-180.1020, and 1200. "First Tier Covered Transactions" refers to any covered transaction between a recipient or subrecipient of Federal funds and a participant (such as the prime or general contract). "Lower Tier Covered Transactions" refers to any covered transaction under a First Tier Covered Transaction (such as subcontracts). "First Tier Participant" refers to the participant who has entered into a covered transaction with a recipient or subrecipient of Federal funds (such as the prime or general contractor). "Lower Tier Participant" refers any participant who has entered into a covered transaction with a First Tier Participant or other Lower Tier Participants (such as subcontractors and suppliers).

f. The prospective first tier participant agrees by submitting this proposal that, should the proposed covered transaction be entered into, it shall not knowingly enter into any lower tier covered transaction with a person who is debarred, suspended, declared ineligible, or voluntarily excluded from participation in this covered transaction, unless authorized by the department or agency entering into this transaction. 2 CFR 180.330.

g. The prospective first tier participant further agrees by submitting this proposal that it will include the clause titled "Certification Regarding Debarment, Suspension, Ineligibility and Voluntary Exclusion-Lower Tier Covered Transactions," provided by the department or contracting agency, entering into this covered transaction, without modification, in all lower tier covered transactions and in all solicitations for lower tier covered transactions exceeding the \$25,000 threshold. 2 CFR 180.220 and 180.300.

h. A participant in a covered transaction may rely upon a certification of a prospective participant in a lower tier covered transaction that is not debarred, suspended, ineligible, or voluntarily excluded from the covered transaction, unless it knows that the certification is erroneous. 2 CFR 180.300; 180.320, and 180.325. A participant is responsible for ensuring that its principals are not suspended, debarred, or otherwise ineligible to participate in covered transactions. 2 CFR 180.335. To verify the eligibility of its principals, as well as the eligibility of any lower tier prospective participants, each participant may, but is not required to, check the System for Award Management website (<https://www.sam.gov/>). 2 CFR 180.300, 180.320, and 180.325.

i. Nothing contained in the foregoing shall be construed to require the establishment of a system of records in order to render in good faith the certification required by this clause. The knowledge and information of the prospective participant is not required to exceed that which is normally possessed by a prudent person in the ordinary course of business dealings.

j. Except for transactions authorized under paragraph (f) of these instructions, if a participant in a covered transaction knowingly enters into a lower tier covered transaction with a person who is suspended, debarred, ineligible, or voluntarily excluded from participation in this transaction, in addition to other remedies available to the Federal Government, the department or agency may terminate this transaction for cause or default. 2 CFR 180.325.

2. Certification Regarding Debarment, Suspension, Ineligibility and Voluntary Exclusion – First Tier Participants:

a. The prospective first tier participant certifies to the best of its knowledge and belief, that it and its principals:

(1) Are not presently debarred, suspended, proposed for debarment, declared ineligible, or voluntarily excluded from participating in covered transactions by any Federal department or agency, 2 CFR 180.335;.

(2) Have not within a three-year period preceding this proposal been convicted of or had a civil judgment rendered against them for commission of fraud or a criminal offense in connection with obtaining, attempting to obtain, or performing a public (Federal, State, or local) transaction or contract under a public transaction; violation of Federal or State antitrust statutes or commission of embezzlement, theft, forgery, bribery, falsification or destruction of records, making false statements, or receiving stolen property, 2 CFR 180.800;

(3) Are not presently indicted for or otherwise criminally or civilly charged by a governmental entity (Federal, State or local) with commission of any of the offenses enumerated in paragraph (a)(2) of this certification, 2 CFR 180.700 and 180.800; and

(4) Have not within a three-year period preceding this application/proposal had one or more public transactions (Federal, State or local) terminated for cause or default. 2 CFR 180.335(d).

(5) Are not a corporation that has been convicted of a felony violation under any Federal law within the two-year period preceding this proposal (USDOT Order 4200.6 implementing appropriations act requirements); and

(6) Are not a corporation with any unpaid Federal tax liability that has been assessed, for which all judicial and administrative remedies have been exhausted, or have lapsed, and that is not being paid in a timely manner pursuant to an agreement with the authority responsible for collecting the tax liability (USDOT Order 4200.6 implementing appropriations act requirements).

b. Where the prospective participant is unable to certify to any of the statements in this certification, such prospective participant should attach an explanation to this proposal. 2 CFR 180.335 and 180.340.

3. Instructions for Certification - Lower Tier Participants:

(Applicable to all subcontracts, purchase orders, and other lower tier transactions requiring prior FHWA approval or estimated to cost \$25,000 or more - 2 CFR Parts 180 and 1200). 2 CFR 180.220 and 1200.220.

a. By signing and submitting this proposal, the prospective lower tier participant is providing the certification set out below.

b. The certification in this clause is a material representation of fact upon which reliance was placed when this transaction was entered into. If it is later determined that the prospective lower tier participant knowingly rendered an erroneous certification, in addition to other remedies available to the Federal Government, the department, or agency with which

this transaction originated may pursue available remedies, including suspension and/or debarment.

c. The prospective lower tier participant shall provide immediate written notice to the person to which this proposal is submitted if at any time the prospective lower tier participant learns that its certification was erroneous by reason of changed circumstances. 2 CFR 180.365.

d. The terms "covered transaction," "debarred," "suspended," "ineligible," "participant," "person," "principal," and "voluntarily excluded," as used in this clause, are defined in 2 CFR Parts 180, Subpart I, 180.900 – 180.1020, and 1200. You may contact the person to which this proposal is submitted for assistance in obtaining a copy of those regulations. "First Tier Covered Transactions" refers to any covered transaction between a recipient or subrecipient of Federal funds and a participant (such as the prime or general contract). "Lower Tier Covered Transactions" refers to any covered transaction under a First Tier Covered Transaction (such as subcontracts). "First Tier Participant" refers to the participant who has entered into a covered transaction with a recipient or subrecipient of Federal funds (such as the prime or general contractor). "Lower Tier Participant" refers any participant who has entered into a covered transaction with a First Tier Participant or other Lower Tier Participants (such as subcontractors and suppliers).

e. The prospective lower tier participant agrees by submitting this proposal that, should the proposed covered transaction be entered into, it shall not knowingly enter into any lower tier covered transaction with a person who is debarred, suspended, declared ineligible, or voluntarily excluded from participation in this covered transaction, unless authorized by the department or agency with which this transaction originated. 2 CFR 1200.220 and 1200.332.

f. The prospective lower tier participant further agrees by submitting this proposal that it will include this clause titled "Certification Regarding Debarment, Suspension, Ineligibility and Voluntary Exclusion-Lower Tier Covered Transaction," without modification, in all lower tier covered transactions and in all solicitations for lower tier covered transactions exceeding the \$25,000 threshold. 2 CFR 180.220 and 1200.220.

g. A participant in a covered transaction may rely upon a certification of a prospective participant in a lower tier covered transaction that is not debarred, suspended, ineligible, or voluntarily excluded from the covered transaction, unless it knows that the certification is erroneous. A participant is responsible for ensuring that its principals are not suspended, debarred, or otherwise ineligible to participate in covered transactions. To verify the eligibility of its principals, as well as the eligibility of any lower tier prospective participants, each participant may, but is not required to, check the System for Award Management website (<https://www.sam.gov/>), which is compiled by the General Services Administration. 2 CFR 180.300, 180.320, 180.330, and 180.335.

h. Nothing contained in the foregoing shall be construed to require establishment of a system of records in order to render in good faith the certification required by this clause. The knowledge and information of participant is not required to exceed that which is normally possessed by a prudent person in the ordinary course of business dealings.

i. Except for transactions authorized under paragraph e of these instructions, if a participant in a covered transaction knowingly enters into a lower tier covered transaction with a person who is suspended, debarred, ineligible, or voluntarily

excluded from participation in this transaction, in addition to other remedies available to the Federal Government, the department or agency with which this transaction originated may pursue available remedies, including suspension and/or debarment. 2 CFR 180.325.

4. Certification Regarding Debarment, Suspension, Ineligibility and Voluntary Exclusion--Lower Tier Participants:

a. The prospective lower tier participant certifies, by submission of this proposal, that neither it nor its principals:

(1) is presently debarred, suspended, proposed for debarment, declared ineligible, or voluntarily excluded from participating in covered transactions by any Federal department or agency, 2 CFR 180.355;

(2) is a corporation that has been convicted of a felony violation under any Federal law within the two-year period preceding this proposal (USDOT Order 4200.6 implementing appropriations act requirements); and

(3) is a corporation with any unpaid Federal tax liability that has been assessed, for which all judicial and administrative remedies have been exhausted, or have lapsed, and that is not being paid in a timely manner pursuant to an agreement with the authority responsible for collecting the tax liability. (USDOT Order 4200.6 implementing appropriations act requirements)

b. Where the prospective lower tier participant is unable to certify to any of the statements in this certification, such prospective participant should attach an explanation to this proposal.

XI. CERTIFICATION REGARDING USE OF CONTRACT FUNDS FOR LOBBYING

This provision is applicable to all Federal-aid construction contracts and to all related subcontracts which exceed \$100,000. 49 CFR Part 20, App. A.

1. The prospective participant certifies, by signing and submitting this bid or proposal, to the best of his or her knowledge and belief, that:

a. No Federal appropriated funds have been paid or will be paid, by or on behalf of the undersigned, to any person for influencing or attempting to influence an officer or employee of any Federal agency, a Member of Congress, an officer or employee of Congress, or an employee of a Member of Congress in connection with the awarding of any Federal contract, the making of any Federal grant, the making of any Federal loan, the entering into of any cooperative agreement, and the extension, continuation, renewal, amendment, or modification of any Federal contract, grant, loan, or cooperative agreement.

b. If any funds other than Federal appropriated funds have been paid or will be paid to any person for influencing or attempting to influence an officer or employee of any Federal agency, a Member of Congress, an officer or employee of Congress, or an employee of a Member of Congress in connection with this Federal contract, grant, loan, or

cooperative agreement, the undersigned shall complete and submit Standard Form-LLL, "Disclosure Form to Report Lobbying," in accordance with its instructions.

2. This certification is a material representation of fact upon which reliance was placed when this transaction was made or entered into. Submission of this certification is a prerequisite for making or entering into this transaction imposed by 31 U.S.C. 1352. Any person who fails to file the required certification shall be subject to a civil penalty of not less than \$10,000 and not more than \$100,000 for each such failure.

3. The prospective participant also agrees by submitting its bid or proposal that the participant shall require that the language of this certification be included in all lower tier subcontracts, which exceed \$100,000 and that all such recipients shall certify and disclose accordingly.

XII. USE OF UNITED STATES-FLAG VESSELS:

This provision is applicable to all Federal-aid construction contracts, design-build contracts, subcontracts, lower-tier subcontracts, purchase orders, lease agreements, or any other covered transaction. 46 CFR Part 381.

This requirement applies to material or equipment that is acquired for a specific Federal-aid highway project. 46 CFR 381.7. It is not applicable to goods or materials that come into inventories independent of an FHWA funded-contract.

When oceanic shipments (or shipments across the Great Lakes) are necessary for materials or equipment acquired for a specific Federal-aid construction project, the bidder, proposer, contractor, subcontractor, or vendor agrees:

1. To utilize privately owned United States-flag commercial vessels to ship at least 50 percent of the gross tonnage (computed separately for dry bulk carriers, dry cargo liners, and tankers) involved, whenever shipping any equipment, material, or commodities pursuant to this contract, to the extent such vessels are available at fair and reasonable rates for United States-flag commercial vessels. 46 CFR 381.7.

2. To furnish within 20 days following the date of loading for shipments originating within the United States or within 30 working days following the date of loading for shipments originating outside the United States, a legible copy of a rated, 'on-board' commercial ocean bill-of-lading in English for each shipment of cargo described in paragraph (b)(1) of this section to both the Contracting Officer (through the prime contractor in the case of subcontractor bills-of-lading) and to the Office of Cargo and Commercial Sealift (MAR-620), Maritime Administration, Washington, DC 20590. (MARAD requires copies of the ocean carrier's (master) bills of lading, certified onboard, dated, with rates and charges. These bills of lading may contain business sensitive information and therefore may be submitted directly to MARAD by the Ocean Transportation Intermediary on behalf of the contractor). 46 CFR 381.7.

**ATTACHMENT A - EMPLOYMENT AND MATERIALS
PREFERENCE FOR APPALACHIAN DEVELOPMENT
HIGHWAY SYSTEM OR APPALACHIAN LOCAL ACCESS
ROAD CONTRACTS (23 CFR 633, Subpart B, Appendix B)**

This provision is applicable to all Federal-aid projects funded under the Appalachian Regional Development Act of 1965.

1. During the performance of this contract, the contractor undertaking to do work which is, or reasonably may be, done as on-site work, shall give preference to qualified persons who regularly reside in the labor area as designated by the DOL wherein the contract work is situated, or the subregion, or the Appalachian counties of the State wherein the contract work is situated, except:

a. To the extent that qualified persons regularly residing in the area are not available.

b. For the reasonable needs of the contractor to employ supervisory or specially experienced personnel necessary to assure an efficient execution of the contract work.

c. For the obligation of the contractor to offer employment to present or former employees as the result of a lawful collective bargaining contract, provided that the number of nonresident persons employed under this subparagraph (1c) shall not exceed 20 percent of the total number of employees employed by the contractor on the contract work, except as provided in subparagraph (4) below.

2. The contractor shall place a job order with the State Employment Service indicating (a) the classifications of the laborers, mechanics and other employees required to perform the contract work, (b) the number of employees required in each classification, (c) the date on which the participant estimates such employees will be required, and (d) any other pertinent information required by the State Employment Service to complete the job order form. The job order may be placed with the State Employment Service in writing or by telephone. If during the course of the contract work, the information submitted by the contractor in the original job order is substantially modified, the participant shall promptly notify the State Employment Service.

3. The contractor shall give full consideration to all qualified job applicants referred to him by the State Employment Service. The contractor is not required to grant employment to any job applicants who, in his opinion, are not qualified to perform the classification of work required.

4. If, within one week following the placing of a job order by the contractor with the State Employment Service, the State Employment Service is unable to refer any qualified job applicants to the contractor, or less than the number requested, the State Employment Service will forward a certificate to the contractor indicating the unavailability of applicants. Such certificate shall be made a part of the contractor's permanent project records. Upon receipt of this certificate, the contractor may employ persons who do not normally reside in the labor area to fill positions covered by the certificate, notwithstanding the provisions of subparagraph (1c) above.

5. The provisions of 23 CFR 633.207(e) allow the contracting agency to provide a contractual preference for the use of mineral resource materials native to the Appalachian region.

6. The contractor shall include the provisions of Sections 1 through 4 of this Attachment A in every subcontract for work which is, or reasonably may be, done as on-site work.

Special Provisions

SPECIAL PROVISIONS - CONTENTS

INTRODUCTION TO THE SPECIAL PROVISIONS.....		VII
DESCRIPTION OF WORK.....		1
1-01 DEFINITIONS AND TERMS.....		1
1-01.3	Definitions <i>Modification</i>	1
1-02 BID PROCEDURES AND CONDITIONS.....		3
1-02.1	Prequalification of Bidders <i>Replacement</i>	3
1-02.2	Plans and Specifications <i>Replacement</i>	3
1-02.5	Proposal Form <i>Replacement</i>	4
1-02.6	Preparation of Proposal <i>Modification</i>	4
1-02.9	Delivery of Proposal <i>Supplement</i>	7
1-02.10	Withdrawing, Revising, or Supplementing Proposal <i>Replacement</i>	8
1-02.13	Irregular Proposals <i>Replacement</i>	9
1-02.14	Disqualification of Bidders <i>Modification</i>	10
1-02.15	Pre Award Information <i>Modification</i>	10
1-03 AWARD AND EXECUTION OF CONTRACT.....		11
1-03.1	Consideration of Bids.....	11
1-03.3	Execution of Contract <i>Modification</i>	11
1-03.4	Contract Bond <i>Modification</i>	12
1-03.7	Judicial Review <i>Modification</i>	13
1-04 SCOPE OF THE WORK.....		13
1-04.2	Coordination of Contract Documents, Plans, Special Provisions, Specifications, and Addenda <i>Modification</i>	13
1-04.4	Changes <i>Modification</i>	14
1-05 CONTROL OF WORK.....		14
1-05.4	Conformity With and Deviation from Plans and Stakes <i>Supplement</i>	14
1-05.7	Removal of Defective and Unauthorized Work <i>Supplement</i>	17
1-05.11	Final Inspection <i>Replacement</i>	17
1-05.11	Final Inspections and Operational Testing.....	18
1-05.11(1)	Substantial Completion Date.....	18
1-05.11(2)	Final Inspection and Physical Completion Date.....	18
1-05.11(3)	Operational Testing.....	19
1-05.13	Superintendents, Labor and Equipment of Contractor <i>Modification</i>	19
1-05.14	Cooperation with Other Contractors <i>Supplement</i>	19
1-05.15	Method of Serving Notices <i>Modification</i>	20
1-05.16	Water and Power <i>New</i>	20
1-06	CONTROL OF MATERIAL.....	20
1-06.1(4)	Fabrication Inspection Expense <i>Modification</i>	24
1-06.2(2)B	Financial Incentive.....	24
1-06.6	Recycled Materials <i>Modification</i>	24
1-07 LEGAL RELATIONS AND RESPONSIBILITIES TO THE PUBLIC.....		25

1-07.1	Laws to be Observed <i>Supplement</i>	25
1-07.1(2)	Health and Safety <i>Supplement</i>	25
1-07.2	State Taxes <i>Replacement</i>	26
1-07.2	State Sales Tax.....	26
1-07.2(1)	State Sales Tax — Rule 171.....	26
1-07.2(2)	State Sales Tax — Rule 170.....	26
1-07.2(3)	Services.....	27
1-07.7	Load Limits <i>Supplement</i>	27
1-07.9	Wages.....	27
1-07.9(1)	General <i>Supplement</i>	27
1-07.9(5)A	Required Documents <i>Modification</i>	28
1-07.11	Requirements for Nondiscrimination <i>Supplement</i>	28
1-07.11(2)	Contractual Requirements <i>Supplement</i>	50
1-07.12	Federal Agency Inspection <i>Supplement</i>	51
1-07.17	Utilities and Similar Facilities <i>Supplement</i>	51
1-07.18	Public Liability and Property Damage Insurance <i>Replacement</i>	53
1-07.23(1)	Construction Under Traffic <i>Supplement</i>	56
1-07.24	Rights of Way <i>Replacement</i>	57
1-08	PROSECUTION AND PROGRESS.....	58
1-08.0	Preliminary Matters <i>New</i>	58
1-08.0(1)	Preconstruction Conference.....	58
1-08.0(2)	Hours of Work <i>New</i>	59
1-08.1	Subcontracting <i>Supplement</i>	60
1-08.1(7)	Payments to Subcontractors and Lower-Tier Subcontractors <i>Revision</i>	60
1-08.1(9)	Submittal of Executed DBE Subcontracts <i>Supplement</i>	61
1-08.3(2)A	Type A Progress Schedule <i>Revision</i>	61
1-08.4	Prosecution of Work <i>Replacement</i>	62
1-08.5	Time for Completion <i>Supplement</i>	62
1-08.9	Liquidated Damages <i>Replacement</i>	63
1-09	MEASUREMENT AND PAYMENT.....	64
1-09.2(1)	General Requirements for Weighing Equipment <i>Modification</i>	64
1-09.2(5)	Measurement <i>Modification</i>	64
1-09.6	Force Account <i>Supplement</i>	64
1-09.9	Payments <i>Modification</i>	65
1-09.9(1)	Retainage <i>Replacement</i>	66
1-09.11(3)	Time Limitation and Jurisdiction <i>Modification</i>	66
1-09.13(3)A	Arbitration General <i>Modification</i>	66
1-09.13(4)	Venue for Litigation <i>Modification</i>	67
1-10	TEMPORARY TRAFFIC CONTROL.....	67
1-10.2	Traffic Control Management <i>Supplement</i>	67
1-10.2(1)	General <i>Supplement</i>	67
1-10.4	Measurement.....	68
1-10.4(2)	Item Bids with Lump Sum for Incidentals <i>Supplement</i>	68
1-10.5	Payment.....	68
1-10.5(2)	Item Bids with lump Sum for Incidentals <i>Supplement</i>	68
2-01	CLEARING AND GRUBBING.....	70

2-01.1	Description <i>Supplement</i>	70
2-01.2	Disposal of Usable Material and Debris <i>Supplement</i>	70
2-01.5	Disposal of Usable Material and Debris <i>Supplement</i>	70
2-02	REMOVAL OF STRUCTURES AND OBSTRUCTIONS.....	71
2-02.1	Description <i>Supplement</i>	71
2-02.3	Construction Requirements <i>Supplement</i>	72
2-02.3(3)	Removal of Pavement, Sidewalks, and Curbs <i>Supplement</i>	72
2-02.3(4)	Cutting Pavement, Sidewalks, and Curbs <i>New</i>	73
2-02.4	Measurement <i>Supplement</i>	73
2-02.5	Payment <i>Supplement</i>	73
3-01	PRODUCTION FROM QUARRY AND PIT SITES.....	75
3-01.4	Contractor-Furnished Material Sources <i>Supplement</i>	75
3-01.6	Payment <i>Replacement</i>	75
4-04	BALLAST AND CRUSHED SURFACING.....	76
4-04.1	Description <i>Supplement</i>	76
4-04.4	Measurement <i>Supplement</i>	76
4-04.5	Payment <i>Supplement</i>	76
5-04	HOT MIX ASPHALT	78
5-04	Hot Mix Asphalt <i>Replacement</i>	78
5-04.1	Description.....	78
5-04.2	Materials	78
5-04.2(1)	How to Get an HMA Mix Design on the QPL	79
5-04.2(1)A	Vacant.....	79
5-04.2(2)	Mix Design - Obtaining Project Approval	79
5-04.2(2)B	Using Warm Mix Asphalt Processes.....	80
5-04.3	Construction Requirements.....	81
5-04.3(1)	Weather Limitations.....	81
5-04.3(2)	Paving Under Traffic.....	81
5-04.3(3)	Equipment	82
5-04.3(3)A	Mixing Plant	82
5-04.3(3)B	Hauling Equipment.....	83
5-04.3(3)C	Pavers.....	83
5-04.3(3)D	Material Transfer Device or Material Transfer Vehicle.....	84
5-04.3(3)E	Rollers.....	85
5-04.3(4)	Preparation of Existing Paved Surfaces.....	85
5-04.3(4)A	Crack Sealing.....	86
5-04.3(4)B	Vacant.....	86
5-04.3(4)C	Pavement Repair	86
5-04.3(5)	Producing/Stockpiling Aggregates and RAP	87
5-04.3(5)A	Vacant.....	87
5-04.3(6)	Mixing.....	87
5-04.3(7)	Spreading and Finishing	88
5-04.3(8)	Aggregate Acceptance Prior to Incorporation in HMA.....	88
5-04.3(9)	HMA Mixture Acceptance	88
5-04.3(9)A	Vacant.....	90
5-04.3(9)B	Vacant.....	90

5-04.3(9)C	Mixture Acceptance – Nonstatistical Evaluation	90
5-04.3(9)C1	Mixture Nonstatistical Evaluation – Lots and Sublots	90
5-04.3(9)C2	Mixture Nonstatistical Evaluation Sampling	91
5-04.3(9)C3	Mixture Nonstatistical Evaluation – Acceptance Testing.....	91
5-04.3(9)C4	Mixture Nonstatistical Evaluation – Pay Factors	91
5-04.3(9)C5	Vacant.....	92
5-04.3(9)C6	Mixture Nonstatistical Evaluation – Price Adjustments	92
5-04.3(9)C7	Mixture Nonstatistical Evaluation - Retests	92
5-04.3 (9)D	Mixture Acceptance – Commercial Evaluation	93
5-04.3(10)	HMA Compaction Acceptance	93
Test Results 94		
5-04.3(10)A	HMA Compaction – General Compaction Requirements	94
5-04.3(10)B	HMA Compaction - Cyclic Density	95
5-04.3(10)C	Vacant.....	95
5-04.3(10)D	HMA Nonstatistical Compaction	95
5-04.3(10)D1	HMA Nonstatistical Compaction - Lots and Sublots.....	95
5-04.3(10)D2	HMA Compaction Nonstatistical Evaluation – Acceptance Testing.....	96
5-04.3(10)D3	HMA Nonstatistical Compaction – Price Adjustments.....	96
5-04.3(11)	Reject Work.....	96
5-04.3(11)A	Reject Work General	96
5-04.3(11)B	Rejection by Contractor	96
5-04.3(11)C	Rejection Without Testing (Mixture or Compaction).....	97
5-04.3(11)D	Rejection - A Partial Sublot	97
5-04.3(11)E	Rejection - An Entire Sublot	97
5-04.3(11)F	Rejection - A Lot in Progress	97
5-04.3(11)G	Rejection - An Entire Lot (Mixture or Compaction)	98
5-04.3(12)	Joints	98
5-04.3(12)A	HMA Joints.....	98
5-04.3(12)A1	Transverse Joints	98
5-04.3(12)A2	Longitudinal Joints.....	98
5-04.3(12)B	Bridge Paving Joint Seals.....	98
5-04.3(13)	Surface Smoothness	98
5-04.3(14)	Planing Bituminous Pavement	99
5-04.3(14)A	Pre-Planing Metal Detection Check.....	100
5-04.3(14)B	Paving and Planing Under Traffic	101
5-04.3(14)B1	General	101
5-04.3(14)B2	Submittals - Planing Plan and HMA Paving Plan	102
5-04.3(14)B3	Pre-Paving and Pre-Planing Briefing	103
5-04.3(15)	Sealing Pavement Surfaces.....	105
5-04.3(16)	HMA Road Approaches	105
5-04.4	Measurement.....	105
5-04.5(2)	Asphalt Cost Price Adjustment <i>New</i>	105
7-05	MANHOLES, INLETS, CATCH BASINS, AND DRYWELLS.....	108
7-05.2	Materials <i>Supplement</i>	108
7-05.3(1)	Adjusting Manholes and Catch Basins to Grade <i>Supplement</i>	108
7-05.5	Payment <i>Supplement</i>	108
7-20	MONUMENT CASTING, VALVE, WATER METER, AND JUNCTION BOXES	
ADJUSTMENT TO GRADE		109

7-20.1	Description <i>New</i>	109
7-20.2	Materials <i>New</i>	109
7-20.3	Construction Requirements <i>New</i>	109
7-20.3(1)	Adjusting Valve Box <i>New</i>	110
7-20.4	Measurement <i>New</i>	110
7-20.5	Payment <i>New</i>	110
8-01	EROSION CONTROL	111
8-01.3	Construction Requirements <i>Modification</i>	111
8-01.3(8)	Street Cleaning <i>Supplement</i>	111
8-01.3(9)D	Inlet Protection <i>Supplement</i>	111
8-01.4	Measurement <i>Modification</i>	111
8-01.5	Payment <i>Supplement</i>	111
8-04	CURBS, GUTTERS, AND SPILLWAYS	112
8-04.3	Construction Requirements <i>Supplement</i>	112
8-04.5	Payment <i>Supplement</i>	112
8-09	RAISED PAVEMENT MARKERS	113
8-09.5	Payment <i>Supplement</i>	113
8-14	CEMENT CONCRETE SIDEWALKS	113
8-14.2	Materials <i>Supplement</i>	113
8-14.3	Construction Requirements <i>Supplement</i>	113
8-14.3(4)	Curing <i>Replacement</i>	113
8-14.3(6)	Curb Ramp <i>New</i>	114
8-14.3(7)	Sidewalk Treatment Around Utility, Luminaire and Signal Poles <i>New</i>	114
8-14.5	Payment <i>Supplement</i>	114
8-21	PERMANENT SIGNING	115
8-21.1	Description <i>Supplement</i>	115
8-21.3(5)	Sign Relocation <i>Supplement</i>	115
8-21.3(12)	Steel Sign Posts <i>Replacement</i>	115
8-21.3(13)	Existing Sign Maintenance <i>New</i>	116
8-21.4	Measurement <i>Replacement</i>	116
8-21.5	Payment <i>Supplement</i>	116
8-22	PAVEMENT MARKING	117
8-22.1	Description <i>Supplement</i>	117
8-22.2	Materials <i>Supplement</i>	117
8-22.3(2)	Preparation of Roadway Surfaces <i>Supplement</i>	117
8-22.3(5)	Installation Instructions <i>Supplement</i>	118
8-22.4	Measurement <i>Supplement</i>	118
8-22.5	Payment <i>Supplement</i>	118
9-03	AGGREGATES	119
9-03.8(2)	HMA Test Requirements <i>Supplement</i>	119
9-03.8(7)	HMA Tolerance and Adjustments <i>Modification</i>	119
	Standard Plans <i>New</i>	120

INTRODUCTION TO THE SPECIAL PROVISIONS

(January 4, 2024 APWA GSP, Option A)

The work on this project shall be accomplished in accordance with the *Standard Specifications for Road, Bridge and Municipal Construction*, 2024 edition, as issued by the Washington State Department of Transportation (WSDOT) and the American Public Works Association (APWA), Washington State Chapter (hereafter “Standard Specifications”). The Standard Specifications, as modified or supplemented by these Special Provisions, all of which are made a part of the Contract Documents, shall govern all of the Work.

These Special Provisions are made up of both General Special Provisions (GSPs) from various sources, which may have project-specific fill-ins; and project-specific Special Provisions. Each Provision either supplements, modifies, or replaces the comparable Standard Specification, or is a new Provision. The deletion, amendment, alteration, or addition to any subsection or portion of the Standard Specifications is meant to pertain only to that particular portion of the section, and in no way should it be interpreted that the balance of the section does not apply.

The GSPs are labeled under the headers of each GSP, with the effective date of the GSP and its source. For example:

(March 8, 2013 APWA GSP)
(April 1, 2013 WSDOT GSP)

Project specific special provisions are labeled without a date as such:
*(*****)*

Also incorporated into the Contract Documents by reference are:

- *Manual on Uniform Traffic Control Devices for Streets and Highways*, currently adopted edition, with Washington State modifications, if any
- *Standard Plans for Road, Bridge and Municipal Construction*, WSDOT Manual M21-01, current edition
- City of Lakewood Public Works Department Standard Plans, current edition
-

DIVISION 1 GENERAL REQUIREMENTS

DESCRIPTION OF WORK

(WSDOT March 13, 1995)

This Contract provides for the improvement of South Tacoma Way between 96th St. SW and Steilacoom Boulevard. Improvements include pavement repair, grinding, two-inch overlay, channelization, upgrading sidewalk ramps to conform with ADA, signage, and other work, all in accordance with the attached Contract Plans, these Contract Provisions, and the Standard Specifications.

1-01 DEFINITIONS AND TERMS

1-01.3 Definitions

Modification

(January 19, 2022 APWA GSP)

Delete the heading **Completion Dates** and the three paragraphs that follow it, and replace them with the following:

Dates

Bid Opening Date

The date on which the Contracting Agency publicly opens and reads the Bids.

Award Date

The date of the formal decision of the Contracting Agency to accept the lowest responsible and responsive Bidder for the Work.

Contract Execution Date

The date the Contracting Agency officially binds the Agency to the Contract.

Notice to Proceed Date

The date stated in the Notice to Proceed on which the Contract time begins.

Substantial Completion Date

The day the Engineer determines the Contracting Agency has full and unrestricted use and benefit of the facilities, both from the operational and safety standpoint, any remaining traffic disruptions will be rare and brief, and only minor incidental work, replacement of temporary substitute facilities, plant establishment periods, or correction or repair remains for the Physical Completion of the total Contract.

Physical Completion Date

The day all of the Work is physically completed on the project. All documentation required by the Contract and required by law does not necessarily need to be furnished by the Contractor by this date.

Completion Date

The day all the Work specified in the Contract is completed and all the obligations of the Contractor under the contract are fulfilled by the Contractor. All documentation required by the Contract and required by law must be furnished by the Contractor before establishment of this date.

Final Acceptance Date

The date on which the Contracting Agency accepts the Work as complete.

Supplement this Section with the following:

All references in the Standard Specifications or WSDOT General Special Provisions, to the terms “Department of Transportation”, “Washington State Transportation Commission”, “Commission”, “Secretary of Transportation”, “Secretary”, “Headquarters”, and “State Treasurer” shall be revised to read “Contracting Agency”.

All references to the terms “State” or “state” shall be revised to read “Contracting Agency” unless the reference is to an administrative agency of the State of Washington, a State statute or regulation, or the context reasonably indicates otherwise.

All references to “State Materials Laboratory” shall be revised to read “Contracting Agency designated location”.

All references to “final contract voucher certification” shall be interpreted to mean the Contracting Agency form(s) by which final payment is authorized, and final completion and acceptance granted.

Additive

A supplemental unit of work or group of bid items, identified separately in the Bid Proposal, which may, at the discretion of the Contracting Agency, be awarded in addition to the base bid.

Alternate

One of two or more units of work or groups of bid items, identified separately in the Bid Proposal, from which the Contracting Agency may make a choice between different methods or material of construction for performing the same work.

Business Day

A business day is any day from Monday through Friday except holidays as listed in Section 1-08.5.

Contract Bond

The definition in the Standard Specifications for “Contract Bond” applies to whatever bond form(s) are required by the Contract Documents, which may be a combination of a Payment Bond and a Performance Bond.

Contract Documents

See definition for “Contract”.

Contract Time

The period of time established by the terms and conditions of the Contract within which the Work must be physically completed.

Notice of Award

The written notice from the Contracting Agency to the successful Bidder signifying the Contracting Agency's acceptance of the Bid Proposal.

Notice to Proceed

The written notice from the Contracting Agency or Engineer to the Contractor authorizing and directing the Contractor to proceed with the Work and establishing the date on which the Contract time begins.

Traffic

Both vehicular and non-vehicular traffic, such as pedestrians, bicyclists, wheelchairs, and equestrian traffic.

1-02 BID PROCEDURES AND CONDITIONS**1-02.1 Prequalification of Bidders***Replacement*

Delete Section 1-02.1 and replace it with the following:

1-02.1 Qualifications of Bidder

(January 24, 2011 APWA GSP)

Before award of a public works contract, a bidder must meet at least the minimum qualifications of RCW 39.04.350(1) to be considered a responsible bidder and qualified to be awarded a public works project.

1-02.2 Plans and Specifications*Replacement*

(June 27, 2011 APWA GSP)

Delete this section and replace it with the following:

Information as to where Bid Documents can be obtained or reviewed can be found in the Call for Bids (Advertisement for Bids) for the work.

After award of the contract, plans and specifications will be issued to the Contractor at no cost as detailed below:

To Prime Contractor	No. of Sets	Basis of Distribution
Reduced plans (11" x 17")	3	Furnished automatically upon award.
Contract Provisions	3	Furnished automatically upon award
Large plans (e.g., 22" x 34")	3	Furnished only upon request.

Additional plans and Contract Provisions may be obtained by the Contractor from the source stated in the Call for Bids, at the Contractor’s own expense.

1-02.5 Proposal Form
(July 31, 2017 APWA GSP)

Replacement

Delete this section and replace it with the following:

The Proposal Form will identify the project and its location and describe the work. It will also list estimated quantities, units of measurement, the items of work, and the materials to be furnished at the unit bid prices. The bidder shall complete spaces on the proposal form that call for, but are not limited to, unit prices; extensions; summations; the total bid amount; signatures; date; and, where applicable, retail sales taxes and acknowledgment of addenda; the bidder’s name, address, telephone number, and signature; the bidder’s UDBE/DBE/M/WBE commitment, if applicable; a State of Washington Contractor’s Registration Number; and a Business License Number, if applicable. Bids shall be completed by typing or shall be printed in ink by hand, preferably in black ink. The required certifications are included as part of the Proposal Form.

The Contracting Agency reserves the right to arrange the proposal forms with alternates and additives, if such be to the advantage of the Contracting Agency. The bidder shall bid on all alternates and additives set forth in the Proposal Form unless otherwise specified.

1-02.6 Preparation of Proposal
(November 20, 2023 WSDOT GSP, Option 2)

Modification

The fourth and fifth paragraphs of Section 1-02.6 are deleted.

Section 1-02.6 is supplemented with the following:

(September 3, 2024 WSDOT GSP, Option 3)

The Bidder shall submit with the Bid the following supplemental documents with the Bid in accordance with Section 1-02.9:

- 1) Disadvantaged Business Enterprise Utilization Certification (WSDOT Form 272-056)
- 2) DBE Written Confirmation Form (WSDOT Form 422-031) – For each and every DBE firm listed on the Bidder’s completed Disadvantaged Business Enterprise Utilization Certification, the Bidder shall submit written confirmation from that DBE firm that the DBE is in agreement with the DBE participation commitment that the Bidder has made in the Bidder’s completed Disadvantaged Business Enterprise Utilization Certification.
- 3) Good Faith Effort Documentation – Bidder must submit good faith effort documentation with the Disadvantaged Business Enterprise Utilization Certification only in the event the Bidder’s efforts to solicit sufficient DBE participation have been unsuccessful.
- 4) DBE Item breakdown (WSDOT Form 272-054) The Bidder shall submit a DBE Item Breakdown form defining the scope of work to be performed by each DBE listed on the DBE Utilization Certification.

(September 3, 2024 WSDOT GSP, Option 7)

The Bidder shall submit with their Bid a completed Bidder Questionnaire form (WSDOT Form #272-022). This shall be filled out for each firm who submitted a bid or quote in attempt to participate in the project whether they were successful or not and include the following information:

1. Firm Name;
2. Firm address including ZIP code;
3. Firm’s status as a DBE or non-DBE;
4. Race and gender information for the firm’s majority owner;
5. NAICS code applicable to each scope of work the firm sought to perform in its bid;
6. Age of the firm; and
7. The annual gross receipts of the firm. The Bidder may obtain this information by asking each firm to indicate into what gross receipts bracket they fit (less than \$1 Million; \$1-3 million; \$3-6 million; \$6-10 million; etc.) rather than requesting an exact figure from the firm.

Failure to return this completed form as part of the Bid Proposal package will cause this Bid to be considered irregular in accordance with Section 1-02.13. A copy of this form is included in the Proposal Forms.

(September 3, 2024 APWA GSP 1-02.6, Option A)

The fourth paragraph of Section 1-02.6 is revised to read:

The Bidder shall submit with the Bid the completed Subcontractor List included in the Contracting Agency Proposal Package. If a Subcontractor List Form is not included in the package, use DOT Form 271-015A. The Form shall contain the following:

1. Subcontractors who will perform the work of structural steel installation, rebar installation, heating, ventilation, air conditioning, and plumbing as described in RCW 18.106 and electrical as described in RCW 19.28,
2. The Work those subcontractors will perform on the Contract as described in RCW 39.30.060; and
3. No more than one subcontractor for each category of work identified, except, when subcontractors vary with Bid alternates, in which case the Bidder shall identify which subcontractor will be used for which alternate.

(January 4, 2024 APWA GSP 1-02.6, Option B)

Supplement the second paragraph with the following:

4. If a minimum bid amount has been established for any item, the unit or lump sum price must equal or exceed the minimum amount stated.
5. Any correction to a bid made by interlineation, alteration, or erasure, shall be initialed by the signer of the bid.

Delete the last two paragraphs, and replace them with the following:

The Bidder shall submit with their Bid a completed Contractor Certification Wage Law Compliance form, provided by the Contracting Agency. Failure to return this certification as part of the Bid Proposal package will make this Bid Nonresponsive and ineligible for Award. A Contractor Certification of Wage Law Compliance form is included in the Proposal Forms.

The Bidder shall make no stipulation on the Bid Form, nor qualify the bid in any manner.

A bid by a corporation shall be executed in the corporate name, by the president or a vice president (or other corporate officer accompanied by evidence of authority to sign).

A bid by a partnership shall be executed in the partnership name, and signed by a partner. A copy of the partnership agreement shall be submitted with the Bid Form if any DBE requirements are to be satisfied through such an agreement.

A bid by a joint venture shall be executed in the joint venture name and signed by a member of the joint venture. A copy of the joint venture agreement shall be submitted with the Bid Form if any DBE requirements are to be satisfied through such an agreement.

1-02.9 Delivery of Proposal

Supplement

(July 8, 2024 APWA GSP, Option A)

Delete this section and replace it with the following:

DBE Document submittal requirements

General

Each Proposal shall be submitted in a sealed envelope, with the Project Name and Project Number as stated in the Call for Bids clearly marked on the outside of the envelope, or as otherwise required in the Bid Documents, to ensure proper handling and delivery.

To be considered responsive on a FHWA-funded project, the Bidder may be required to submit the following items, as required by Section 1-02.6:

- DBE Utilization Certification (WSDOT 272-056)
- DBE Written Confirmation Document (WSDOT 422-031) from each DBE firm listed on the Bidder's completed DBE Utilization Certification
- Good Faith Effort (GFE) Documentation (if applicable)
- DBE Bid Item Breakdown (WSDOT 272-054)

Proposals that are received as required will be publicly opened and read as specified in Section 1-02.12. The Contracting Agency will not open or consider any Bid Proposal that is received after the time specified in the Call for Bids for receipt of Bid Proposals, or received in a location other than that specified in the Call for Bids. The Contracting Agency will not open or consider any "Supplemental Information" (Written Confirmations Documents, or GFE Documentation) that is received after the time specified, or received in a location other than that specified in the Call for Bids.

If an emergency or unanticipated event interrupts normal work processes of the Contracting Agency so that Proposals cannot be received at the office designated for receipt of bids as specified in Section 1-02.12 the time specified for receipt of the Proposal will be deemed to be extended to the same time of day specified in the solicitation on the first work day on which the normal work processes of the Contracting Agency resume.

Supplemental bid information submitted after the Proposal submittal but within 48 hours of the time specified for receipt of Proposals, shall be submitted in a sealed envelope labeled the same as for the Proposal, with "Supplemental Information" added.

DBE Utilization Certification (WSDOT Form 272-056)

The DBE Utilization Certification shall be received at the same location and no later than the time required for delivery of the Proposal. The Contracting Agency will not open or consider any Proposal when the DBE Utilization Certification is received after the time specified for receipt of Proposals or received in a location other than that specified for receipt of Proposals. The DBE Utilization Certification may be submitted in the same envelope as the Bid deposit.

DBE Written Confirmation Document (WSDOT Form 422-031) and/or GFE Documentation, (if applicable)

The DBE Written Confirmation Documents and/or GFE Documentations are not required to be submitted with the Proposal. The DBE Written Confirmation Document(s) and/or GFE Documentation (if applicable) shall be received either with the Bid Proposal or as a Supplement to the Bid. Written Confirmation and/or GFE Documentation shall be received no later than 48 hours (not including Saturdays, Sundays and Holidays) after the time for delivery of the Proposal. To be considered responsive, Bidders shall submit a Written Confirmation Document from each DBE firm listed on the Bidder's completed DBE Utilization Certification and/or the GFE Documentation as required by Section 1-02.6.

DBE Bid Item Breakdown Form (WSDOT Form 2720-54)

The DBE Bid Item Breakdown shall be received either with the Bid Proposal or as a Supplement to the Bid. The documents shall be received no later than 48 hours (not including Saturdays, Sundays and Holidays) after the time for delivery of the Proposal. To be considered responsive, Bidders shall submit a completed DBE Bid Item Breakdown, however, the Contractor may correct minor errors to the DBE Bid Item Breakdown for a period up to five calendar days after bid opening (not including Saturdays, Sundays and Holidays) DBE Bid Item Breakdowns that are still incorrect after the correction period will be determined to be non-responsive.

The DBE Bid Item Breakdown will not be included as part of the executed Contract.

1-02.10 Withdrawing, Revising, or Supplementing Proposal *Replacement*
(July 23, 2015 APWA GSP)

Delete this section, and replace it with the following:

After submitting a physical Bid Proposal to the Contracting Agency, the Bidder may withdraw, revise, or supplement it if:

1. The Bidder submits a written request signed by an authorized person and physically delivers it to the place designated for receipt of Bid Proposals, and
2. The Contracting Agency receives the request before the time set for receipt of Bid Proposals, and
3. The revised or supplemented Bid Proposal (if any) is received by the Contracting Agency before the time set for receipt of Bid Proposals.

If the Bidder's request to withdraw, revise, or supplement its Bid Proposal is received before the time set for receipt of Bid Proposals, the Contracting Agency will return the

unopened Proposal package to the Bidder. The Bidder must then submit the revised or supplemented package in its entirety. If the Bidder does not submit a revised or supplemented package, then its bid shall be considered withdrawn.

Late revised or supplemented Bid Proposals or late withdrawal requests will be date recorded by the Contracting Agency and returned unopened. Mailed, emailed, or faxed requests to withdraw, revise, or supplement a Bid Proposal are not acceptable.

1-02.13 Irregular Proposals

Replacement

(September 3, 2024 APWA GSP)

Delete this section and replace it with the following:

1. A Proposal will be considered irregular and will be rejected if:
 - a. The Bidder is not prequalified when so required;
 - b. The Bidder adds provisions reserving the right to reject or accept the Award, or enter into the Contract;
 - c. A price per unit cannot be determined from the Bid Proposal;
 - d. The Proposal form is not properly executed;
 - e. The Bidder fails to submit or properly complete a subcontractor list (WSDOT Form 271-015), if applicable, as required in Section 1-02.6;
 - f. The Bidder fails to submit or properly complete a Disadvantaged Business Enterprise Certification (WSDOT Form 272-056), if applicable, as required in Section 1-02.6;
 - g. The Bidder fails to submit Written Confirmations (WSDOT Form 422-031) from each DBE firm listed on the Bidder's completed DBE Utilization Certification that they are in agreement with the bidder's DBE participation commitment, if applicable, as required in Section 1-02.6, or if the written confirmation that is submitted fails to meet the requirements of the Special Provisions;
 - h. The Bidder fails to submit DBE Good Faith Effort documentation, if applicable, as required in Section 1-02.6, or if the documentation that is submitted fails to demonstrate that a Good Faith Effort to meet the Condition of Award in accordance with Section 1-07.11;
 - i. The Bidder fails to submit a DBE Bid Item Breakdown (WSDOT Form 272-054), if applicable, as required in Section 1-02.6, or if the documentation that is submitted fails to meet the requirements of the Special Provisions;
 - j. The bidder fails to submit the Bidder Questionnaire (DOT Form 272-022), if applicable as required by Section 1-02.6, or if the documentation that is submitted fails to meet the requirements of the Special Provisions; or
 - k. The Bid Proposal does not constitute a definite and unqualified offer to meet the material terms of the Bid invitation.

2. A Proposal may be considered irregular and may be rejected if:
 - a. The Proposal does not include a unit price for every Bid item;
 - b. Any of the unit prices are excessively unbalanced (either above or below the amount of a reasonable Bid) to the potential detriment of the Contracting Agency;
 - c. The authorized Proposal Form furnished by the Contracting Agency is not used or is altered;

- d. The completed Proposal form contains unauthorized additions, deletions, alternate Bids, or conditions;
- e. Receipt of Addenda is not acknowledged;
- f. A member of a joint venture or partnership and the joint venture or partnership submit Proposals for the same project (in such an instance, both Bids may be rejected); or
- g. If Proposal form entries are not made in ink.

1-02.14 Disqualification of Bidders*Modification**(May 17, 2018 APWA GSP, Option A)*

Delete this section, and replace it with the following:

A Bidder will be deemed not responsible if the Bidder does not meet the mandatory bidder responsibility criteria in RCW 39.04.350(1), as amended.

The Contracting Agency will verify that the Bidder meets the mandatory bidder responsibility criteria in RCW 39.04.350(1). To assess bidder responsibility, the Contracting Agency reserves the right to request documentation as needed from the Bidder and third parties concerning the Bidder's compliance with the mandatory bidder responsibility criteria.

If the Contracting Agency determines the Bidder does not meet the mandatory bidder responsibility criteria in RCW 39.04.350(1) and is therefore not a responsible Bidder, the Contracting Agency shall notify the Bidder in writing, with the reasons for its determination. If the Bidder disagrees with this determination, it may appeal the determination within two (2) business days of the Contracting Agency's determination by presenting its appeal and any additional information to the Contracting Agency. The Contracting Agency will consider the appeal and any additional information before issuing its final determination. If the final determination affirms that the Bidder is not responsible, the Contracting Agency will not execute a contract with any other Bidder until at least two business days after the Bidder determined to be not responsible has received the Contracting Agency's final determination.

1-02.15 Pre Award Information*Modification**(December 30, 2022 APWA GSP)*

Revise this section to read:

Before awarding any contract, the Contracting Agency may require one or more of these items or actions of the apparent lowest responsible bidder:

1. A complete statement of the origin, composition, and manufacture of any or all materials to be used,
2. Samples of these materials for quality and fitness tests,
3. A progress schedule (in a form the Contracting Agency requires) showing the order of and time required for the various phases of the work,
4. A breakdown of costs assigned to any bid item,

5. Attendance at a conference with the Engineer or representatives of the Engineer,
6. Obtain, and furnish a copy of, a business license to do business in the city or county where the work is located.
7. Any other information or action taken that is deemed necessary to ensure that the bidder is the lowest responsible bidder.

1-03 AWARD AND EXECUTION OF CONTRACT

1-03.1 Consideration of Bids

(December 30, 2022 APWA GSP)

Revise the first paragraph to read:

After opening and reading proposals, the Contracting Agency will check them for correctness of extensions of the prices per unit and the total price. If a discrepancy exists between the price per unit and the extended amount of any bid item, the price per unit will control. If a minimum bid amount has been established for any item and the bidder's unit or lump sum price is less than the minimum specified amount, the Contracting Agency will unilaterally revise the unit or lump sum price, to the minimum specified amount and recalculate the extension. The total of extensions, corrected where necessary, including sales taxes where applicable and such additives and/or alternates as selected by the Contracting Agency, will be used by the Contracting Agency for award purposes and to fix the Awarded Contract Price amount and the amount of the contract bond.

1-03.3 Execution of Contract

Modification

(July 8, 2024 APWA GSP Option A)

Revise this section to read:

Within 3 calendar days of Award date (not including Saturdays, Sundays and Holidays), the successful Bidder shall provide the information necessary to execute the Contract to the Contracting Agency. The Bidder shall send the contact information, including the full name, email address, and phone number, for the authorized signer and bonding agent to the Contracting Agency.

Copies of the Contract Provisions, including the unsigned Form of Contract, will be available for signature by the successful bidder on the first business day following award. The number of copies to be executed by the Contractor will be determined by the Contracting Agency.

Within 14 calendar days after the award date, the successful bidder shall return the signed Contracting Agency-prepared contract, an insurance certification as required by Section 1-07.18, a satisfactory bond as required by law and Section 1-03.4, the Transfer of Coverage form for the Construction Stormwater General Permit with sections I, III, and VIII completed when provided. Before execution of the contract by the Contracting Agency, the successful bidder shall provide any pre-award information the Contracting Agency may require under Section 1-02.15.

Until the Contracting Agency executes a contract, no proposal shall bind the Contracting Agency nor shall any work begin within the project limits or within Contracting Agency-furnished sites. The Contractor shall bear all risks for any work begun outside such areas and for any materials ordered before the contract is executed by the Contracting Agency.

If the bidder experiences circumstances beyond their control that prevents return of the contract documents within the calendar days after the award date stated above, the Contracting Agency may grant up to a maximum of 5 additional calendar days for return of the documents, provided the Contracting Agency deems the circumstances warrant it.

(July 8, 2024 APWA GSP Option B)

This section is supplemented with the following:

No later than 5 calendar days after the Award date (not including Saturdays, Sundays and Holidays), the successful Bidder shall provide DBE Trucking Credit Form(s) (WSDOT Form 272-058) when trucking appears on the DBE Utilization Certificate (WSDOT Form 272-056). The DBE Trucking Credit Form shall document how the DBE Trucking firm will be able to perform the scope of work subcontracted to them.

Trucking forms will be returned for correction. Trucking Credit Form(s) will not be included as part of the executed Contract.

DBE Trucking Credit Forms shall be submitted in one of the following ways:

- 1) By E-mail eswanstrom@cityoflakewood.us or
- 2) By Mail to: City of Lakewood
Public Works Engineering
Attn: Eric Swanstrom
6000 Main St. SW
Lakewood, WA 98499

1-03.4 Contract Bond

Modification

(July 23, 2015 APWA GSP)

Delete the first paragraph and replace it with the following:

The successful bidder shall provide executed payment and performance bond(s) for the full contract amount. The bond may be a combined payment and performance bond; or be separate payment and performance bonds. In the case of separate payment and performance bonds, each shall be for the full contract amount. The bond(s) shall:

1. Be on Contracting Agency-furnished form(s);
2. Be signed by an approved surety (or sureties) that:
 - a. Is registered with the Washington State Insurance Commissioner, and
 - b. Appears on the current Authorized Insurance List in the State of Washington published by the Office of the Insurance Commissioner,

3. Guarantee that the Contractor will perform and comply with all obligations, duties, and conditions under the Contract, including but not limited to the duty and obligation to indemnify, defend, and protect the Contracting Agency against all losses and claims related directly or indirectly from any failure:
 - a. Of the Contractor (or any of the employees, subcontractors, or lower tier subcontractors of the Contractor) to faithfully perform and comply with all contract obligations, conditions, and duties, or
 - b. Of the Contractor (or the subcontractors or lower tier subcontractors of the Contractor) to pay all laborers, mechanics, subcontractors, lower tier subcontractors, material person, or any other person who provides supplies or provisions for carrying out the work;
4. Be conditioned upon the payment of taxes, increases, and penalties incurred on the project under titles 50, 51, and 82 RCW; and
5. Be accompanied by a power of attorney for the Surety's officer empowered to sign the bond; and
6. Be signed by an officer of the Contractor empowered to sign official statements (sole proprietor or partner). If the Contractor is a corporation, the bond(s) must be signed by the president or vice president, unless accompanied by written proof of the authority of the individual signing the bond(s) to bind the corporation (i.e., corporate resolution, power of attorney, or a letter to such effect signed by the president or vice president).

1-03.7 Judicial Review

Modification

(December 30, 2022 APWA GSP)

Revise this section to read:

All decisions made by the Contracting Agency regarding the Award and execution of the Contract or Bid rejection shall be conclusive subject to the scope of judicial review permitted under Washington Law. Such review, if any, shall be timely filed in the Superior Court of the county where the Contracting Agency headquarters is located, provided that where an action is asserted against a county, RCW 36.01.050 shall control venue and jurisdiction.

1-04 SCOPE OF THE WORK

1-04.2 Coordination of Contract Documents, Plans, Special Provisions, Specifications, and Addenda

Modification

(December 30, 2022 APWA GSP)

Revise the second paragraph to read:

Any inconsistency in the parts of the contract shall be resolved by following this order of precedence (e.g., 1 presiding over 2, 2 over 3, 3 over 4, and so forth):

1. Addenda,

2. Proposal Form,
3. Special Provisions,
4. Contract Plans,
5. Standard Specifications,
6. Contracting Agency’s Standard Plans or Details (if any), and
7. WSDOT Standard Plans for Road, Bridge, and Municipal Construction.

1-04.4 Changes*Modification**(January 19, 2022 APWA GSP)*

The first two sentences of the last paragraph of Section 1-04.4 are deleted.

1-05 CONTROL OF WORK**1-05.4 Conformity With and Deviation from Plans and Stakes***Supplement**(January 13, 2021 WSDOT GSP, Option 2)*

Section 1-05.4 is supplemented with the following:

Contractor Surveying - Roadway

The Contracting Agency has provided primary survey control in the Plans.

The Contractor shall be responsible for setting, maintaining, and resetting all alignment stakes, slope stakes, and grades necessary for the construction of the roadbed, drainage, surfacing, paving, channelization and pavement marking, illumination and signals, guardrails and barriers, and signing. Except for the survey control data to be furnished by the Contracting Agency, calculations, surveying, and measuring required for setting and maintaining the necessary lines and grades shall be the Contractor's responsibility.

The Contractor shall inform the Engineer when monuments are discovered that were not identified in the Plans and construction activity may disturb or damage the monuments. All monuments noted on the plans “DO NOT DISTURB” shall be protected throughout the length of the project or be replaced at the Contractors expense.

Detailed survey records shall be maintained, including a description of the work performed on each shift, the methods utilized, and the control points used. The record shall be adequate to allow the survey to be reproduced. A copy of each day's record shall be provided to the Engineer within three working days after the end of the shift.

The meaning of words and terms used in this provision shall be as listed in "Definitions of Surveying and Associated Terms" current edition, published by the American Congress on Surveying and Mapping and the American Society of Civil Engineers.

The survey work shall include but not be limited to the following:

1. Verify the primary horizontal and vertical control furnished by the Contracting Agency,

and expand into secondary control by adding stakes and hubs as well as additional survey control needed for the project. Provide descriptions of secondary control to the Contracting Agency. The description shall include coordinates and elevations of all secondary control points.

2. Establish, the centerlines of all alignments, by placing hubs, stakes, or marks on centerline or on offsets to centerline at all curve points (PCs, PTs, and PIs) and at points on the alignments spaced no further than 50 feet.
3. Establish clearing limits, placing stakes at all angle points and at intermediate points not more than 50 feet apart. The clearing and grubbing limits shall be 5 feet beyond the toe of a fill and 10 feet beyond the top of a cut unless otherwise shown in the Plans.
4. Establish grading limits, placing slope stakes at centerline increments not more than 50 feet apart. Establish offset reference to all slope stakes. If Global Positioning Satellite (GPS) Machine Controls are used to provide grade control, then slope stakes may be omitted at the discretion of the Contractor
5. Establish the horizontal and vertical location of all drainage features, placing offset stakes to all drainage structures and to pipes at a horizontal interval not greater than 25 feet.
6. Establish roadbed and surfacing elevations by placing stakes at the top of subgrade and at the top of each course of surfacing. Subgrade and surfacing stakes shall be set at horizontal intervals not greater than 50 feet in tangent sections, 25 feet in curve sections with a radius less than 300 feet, and at 10-foot intervals in intersection radii with a radius less than 10 feet. Transversely, stakes shall be placed at all locations where the roadway slope changes and at additional points such that the transverse spacing of stakes is not more than 12 feet. If GPS Machine Controls are used to provide grade control, then roadbed and surfacing stakes may be omitted at the discretion of the Contractor.
7. Establish intermediate elevation benchmarks as needed to check work throughout the project.
8. Provide references for paving pins at 25-foot intervals or provide simultaneous surveying to establish location and elevation of paving pins as they are being placed.
9. For all other types of construction included in this provision, (including but not limited to channelization and pavement marking, illumination and signals, guardrails and barriers, and signing) provide staking and layout as necessary to adequately locate, construct, and check the specific construction activity.
10. Contractor shall determine if changes are needed to the profiles or roadway sections shown in the Contract Plans in order to achieve proper smoothness and drainage where matching into existing features, such as a smooth transition from new pavement to existing pavement. The Contractor shall submit these changes to the Engineer for review and approval 10 days prior to the beginning of work.

The Contractor shall provide the Contracting Agency copies of any calculations and staking data when requested by the Engineer.

The Contractor shall ensure a surveying accuracy within the following tolerances:

	<u>Vertical</u>	<u>Horizontal</u>
Slope stakes	±0.10 feet	±0.10 feet
Subgrade grade stakes set 0.04 feet below grade	±0.01 feet	±0.5 feet (parallel to alignment) ±0.1 feet (normal to alignment)
Stationing on roadway	N/A	±0.1 feet
Alignment on roadway	N/A	±0.04 feet
Surfacing grade stakes	±0.01 feet	±0.5 feet (parallel to alignment) ±0.1 feet (normal to alignment)
Roadway paving pins for surfacing or paving	±0.01 feet	±0.2 feet (parallel to alignment) ±0.1 feet (normal to alignment)

The Contracting Agency may spot-check the Contractor’s surveying. These spot-checks will not change the requirements for normal checking by the Contractor.

When staking roadway alignment and stationing, the Contractor shall perform independent checks from different secondary control to ensure that the points staked are within the specified survey accuracy tolerances.

The Contractor shall calculate coordinates for the alignment. The Contracting Agency will verify these coordinates prior to issuing approval to the Contractor for commencing with the work. The Contracting Agency will require up to seven calendar days from the date the data is received.

Contract work to be performed using contractor-provided stakes shall not begin until the stakes are approved by the Contracting Agency. Such approval shall not relieve the Contractor of responsibility for the accuracy of the stakes.

Stakes shall be marked in accordance with Standard Plan A10.10. When stakes are needed that are not described in the Plans, then those stakes shall be marked, at no additional cost to the Contracting Agency as ordered by the Engineer.

Payment

Payment will be made for the following bid item when included in the proposal:

"Roadway Surveying", lump sum.

The lump sum contract price for "Roadway Surveying" shall be full pay for all labor, equipment, materials, and supervision utilized to perform the Work specified, including any resurveying, checking, correction of errors, replacement of missing or damaged stakes, and coordination efforts.

1-05.7 Removal of Defective and Unauthorized Work*Supplement**(October 1, 2005 APWA GSP)*

Supplement this section with the following:

If the Contractor fails to remedy defective or unauthorized work within the time specified in a written notice from the Engineer, or fails to perform any part of the work required by the Contract Documents, the Engineer may correct and remedy such work as may be identified in the written notice, with Contracting Agency forces or by such other means as the Contracting Agency may deem necessary.

If the Contractor fails to comply with a written order to remedy what the Engineer determines to be an emergency situation, the Engineer may have the defective and unauthorized work corrected immediately, have the rejected work removed and replaced, or have work the Contractor refuses to perform completed by using Contracting Agency or other forces. An emergency situation is any situation when, in the opinion of the Engineer, a delay in its remedy could be potentially unsafe, or might cause serious risk of loss or damage to the public.

Direct or indirect costs incurred by the Contracting Agency attributable to correcting and remedying defective or unauthorized work, or work the Contractor failed or refused to perform, shall be paid by the Contractor. Payment will be deducted by the Engineer from monies due, or to become due, the Contractor. Such direct and indirect costs shall include in particular, but without limitation, compensation for additional professional services required, and costs for repair and replacement of work of others destroyed or damaged by correction, removal, or replacement of the Contractor's unauthorized work.

No adjustment in contract time or compensation will be allowed because of the delay in the performance of the work attributable to the exercise of the Contracting Agency's rights provided by this Section.

The rights exercised under the provisions of this section shall not diminish the Contracting Agency's right to pursue any other avenue for additional remedy or damages with respect to the Contractor's failure to perform the work as required.

1-05.11 Final Inspection*Replacement*

Delete this section and replace it with the following:

1-05.11 Final Inspections and Operational Testing

(October 1, 2005 APWA GSP)

1-05.11(1) Substantial Completion Date

When the Contractor considers the work to be substantially complete, the Contractor shall so notify the Engineer and request the Engineer establish the Substantial Completion Date. The Contractor's request shall list the specific items of work that remain to be completed in order to reach physical completion. The Engineer will schedule an inspection of the work with the Contractor to determine the status of completion. The Engineer may also establish the Substantial Completion Date unilaterally.

If, after this inspection, the Engineer concurs with the Contractor that the work is substantially complete and ready for its intended use, the Engineer, by written notice to the Contractor, will set the Substantial Completion Date. If, after this inspection the Engineer does not consider the work substantially complete and ready for its intended use, the Engineer will, by written notice, so notify the Contractor giving the reasons therefore.

Upon receipt of written notice concurring in or denying substantial completion, whichever is applicable, the Contractor shall pursue vigorously, diligently and without unauthorized interruption, the work necessary to reach Substantial and Physical Completion. The Contractor shall provide the Engineer with a revised schedule indicating when the Contractor expects to reach substantial and physical completion of the work.

The above process shall be repeated until the Engineer establishes the Substantial Completion Date and the Contractor considers the work physically complete and ready for final inspection.

1-05.11(2) Final Inspection and Physical Completion Date

When the Contractor considers the work physically complete and ready for final inspection, the Contractor by written notice, shall request the Engineer to schedule a final inspection. The Engineer will set a date for final inspection. The Engineer and the Contractor will then make a final inspection and the Engineer will notify the Contractor in writing of all particulars in which the final inspection reveals the work incomplete or unacceptable. The Contractor shall immediately take such corrective measures as are necessary to remedy the listed deficiencies. Corrective work shall be pursued vigorously, diligently, and without interruption until physical completion of the listed deficiencies. This process will continue until the Engineer is satisfied the listed deficiencies have been corrected.

If action to correct the listed deficiencies is not initiated within 7 days after receipt of the written notice listing the deficiencies, the Engineer may, upon written notice to the Contractor, take whatever steps are necessary to correct those deficiencies pursuant to Section 1-05.7.

The Contractor will not be allowed an extension of contract time because of a delay in the performance of the work attributable to the exercise of the Engineer's right hereunder.

Upon correction of all deficiencies, the Engineer will notify the Contractor and the Contracting Agency, in writing, of the date upon which the work was considered physically complete. That date shall constitute the Physical Completion Date of the contract, but shall not imply acceptance of the work or that all the obligations of the Contractor under the contract have been fulfilled.

1-05.11(3) Operational Testing

It is the intent of the Contracting Agency to have at the Physical Completion Date a complete and operable system. Therefore when the work involves the installation of machinery or other mechanical equipment; street lighting, electrical distribution or signal systems; irrigation systems; buildings; or other similar work it may be desirable for the Engineer to have the Contractor operate and test the work for a period of time after final inspection but prior to the physical completion date. Whenever items of work are listed in the Contract Provisions for operational testing they shall be fully tested under operating conditions for the time period specified to ensure their acceptability prior to the Physical Completion Date. During and following the test period, the Contractor shall correct any items of workmanship, materials, or equipment which prove faulty, or that are not in first class operating condition. Equipment, electrical controls, meters, or other devices and equipment to be tested during this period shall be tested under the observation of the Engineer, so that the Engineer may determine their suitability for the purpose for which they were installed. The Physical Completion Date cannot be established until testing and corrections have been completed to the satisfaction of the Engineer.

The costs for power, gas, labor, material, supplies, and everything else needed to successfully complete operational testing, shall be included in the unit contract prices related to the system being tested, unless specifically set forth otherwise in the proposal.

Operational and test periods, when required by the Engineer, shall not affect a manufacturer's guaranties or warranties furnished under the terms of the contract.

1-05.13 Superintendents, Labor and Equipment of Contractor *Modification* (August 14, 2013 APWA GSP)

Delete the sixth and seventh paragraphs of this section.

1-05.14 Cooperation with Other Contractors *Supplement* (March 13, 1995, WSDOT GSP, Option 1)

Section 1-05.14 is supplemented with the following:

Other Contracts Or Other Work

It is anticipated that the following work adjacent to or within the limits of this project will be performed by others during the course of this project and will require coordination of the work:

Utility Vault Lid/ Box adjustment

Lumen

Robert Bair
SR Network Implementation Engineer
7850B S Trafton St. Bldg. B
Tacoma, WA 98409
Tel: 253-393-5384 | cell: 253-831-2059
Rob.bair@lumen.com

1-05.15 Method of Serving Notices

Modification

(January 4, 2024 APWA GSP)

Revise the second paragraph to read:

All correspondence from the Contractor shall be served and directed to the Engineer. All correspondence from the Contractor constituting any notification, notice of protest, notice of dispute, or other correspondence constituting notification required to be furnished under the Contract, must be written in paper format, hand delivered or sent via certified mail delivery service with return receipt requested to the Engineer's office. Electronic copies such as e-mails or electronically delivered copies of correspondence will not constitute such notice and will not comply with the requirements of the Contract.

1-05.16 Water and Power

New

(October 1, 2005 APWA GSP)

The Contractor shall make necessary arrangements, and shall bear the costs for power and water necessary for the performance of the work, unless the contract includes power and water as a pay item.

1-06 CONTROL OF MATERIAL

Section 1-06 is supplemented with the following:

Build America/Buy America

(December 20 2023, WSDOT GSP Option 2(A))

General Requirements

In accordance with Buy America Preferences for Infrastructure Projects requirements contained in 2 CFR 184 and Division G, Title IX - Build America, Buy America Act (BABA), of Public Law 117-58 (Infrastructure Investment and Jobs Act), the following materials must be American-made:

1. All steel and iron used in the project are produced in the United States. This means all manufacturing processes, from the initial melting stage through the application of coatings, occurred in the United States.

2. All manufactured products used in the project are produced in the United States. This means the manufactured product was manufactured in the United States, and the cost of the components of the manufactured product that are mined, produced, or manufactured in the United States is greater than 55 percent of the total cost of all components of the manufactured product, unless another standard for determining the minimum amount of domestic content of the manufactured product has been established under applicable law or regulation.
3. All construction materials are manufactured in the United States. This means 21 that all manufacturing processes for the construction material occurred in the 22 United States.

An article, material, or supply will be classified in one of three categories: 1) Steel and Iron, 2) Manufactured Product or 3) Construction Material. Only a single category will apply to an item and be subject to the requirements of the BABA requirements of that category. Some contract items are composed of multiple parts that may fall into different categories. Individual components will be categorized as a construction material, manufactured product, or steel and iron based on their composition when they arrive at the staging area or work site. When steel or iron are a component of a manufactured product or construction material, the steel and iron components will be subject to “Steel and Iron Requirements” of this Specification.

Definitions

1. Construction Material: Defined as any article, material, or supply brought to the construction site for incorporation into the final product. Construction materials include an article, material, or supply that is or consists primarily of:
 - a. Non-ferrous metals including all manufacturing processes, from initial smelting or melting through final shaping, coating, and assembly;
 - b. Plastic and polymer-based products including all manufacturing processes, from initial combination of constituent plastic or polymer-based inputs, or, where applicable, constituent composite materials, until the item is in its final form);
 - c. Glass including all manufacturing processes, from initial batching and melting of raw materials through annealing, cooling, and cutting);
 - d. Fiber optic cable (includes drop cable) including all manufacturing processes, from initial ribboning (if applicable), through buffering, fiber stranding and jacketing, (fiber optic cable also includes the standards for glass and optical fiber);
 - e. Optical fiber including all manufacturing processes, from the initial preform fabrication stage, though the completion of the draw;
 - f. Lumber including all manufacturing processes, from initial debarking through treatment and planing;
 - g. Drywall including all manufacturing processes, from initial blending of mined or synthetic gypsum plaster and additives through cutting and drying of sandwiched panels; or
 - h. Engineered wood including all manufacturing processes from the initial combination of constituent materials until the wood product is in its final form.

Construction Materials do not include items of primarily iron or steel; manufactured products; cement and cementitious materials; aggregates such as stone, sand, or gravel; or aggregate binding agents or additives.

If a Construction Material is not manufactured in the United States it shall be considered a Foreign Construction Material.

2. **Manufactured Product:** A Manufactured product includes any item produced as a result of the manufacturing process. Items that consist of two or more of the listed construction materials that have been combined together through a manufacturing process, and items that include at least one of the listed materials combined with a material that is not listed through a manufacturing process, should be treated as manufactured products, rather than as construction materials.
3. **Manufactured in the United States:** A construction material will be considered as manufactured in the United States if all manufacturing processes have occurred in the United States.
4. **Structural Steel:** Defined as all structural steel products included in the project.
5. **United States:** To further define the coverage, a domestic product is a manufactured steel construction material that was produced in one of the 50 states, the District of Columbia, Puerto Rico, or in the territories and possessions of the United States.

Steel and Iron Requirements

Major quantities of steel and iron construction materials that are permanently incorporated into the project shall consist of American-made materials only. BABA requirements do not apply to temporary steel or iron items, e.g., temporary sheet piling, temporary bridges, steel scaffolding and falsework.

Minor amounts of foreign steel and iron may be utilized in this project provided the cost of the foreign material used does not exceed one-tenth of one percent of the total contract cost or \$2,500.00, whichever is greater.

American-made material is defined as material having all manufacturing processes occurring domestically.

If domestically produced steel billets or iron ingots are exported outside of the area of coverage, as defined above, for any manufacturing process then the resulting product does not conform to the BABA requirements. Additionally, products manufactured domestically from foreign source steel billets or iron ingots do not conform to the BABA requirements because the initial melting and mixing of alloys to create the material occurred in a foreign country.

Manufacturing begins with the initial melting and mixing and continues through the coating stage. Any process which modifies the chemical content, the physical size or shape, or the final finish is considered a manufacturing process. The processes include rolling, extruding, machining, bending, grinding, drilling, welding, and coating. The action of applying a coating to steel or iron is deemed a manufacturing process. Coating includes epoxy coating, galvanizing, aluminizing, painting, and any other coating that protects or enhances the value of steel or iron. Any process from the original reduction from ore to the finished product constitutes a manufacturing process for iron.

Due to a nationwide waiver, BABA requirements do not apply to raw materials (iron ore and alloys), scrap (recycled steel or iron), and pig iron ore processed, pelletized, and reduced iron ore.

The following are considered to be steel manufacturing processes:

1. Production of steel by any of the following processes:
 - a. Open hearth furnace.
 - b. Basic oxygen.
 - c. Electric furnace.
 - d. Direct reduction.
2. Rolling, heat treating, and any other similar processing.
3. Fabrication of the products:
 - a. Spinning wire into cable or strand.
 - b. Corrugating and rolling into culverts.
 - c. Shop fabrication.

A certification of materials origin will be required for all items comprised of, or containing, steel or iron construction materials prior to such items being incorporated into the permanent work. The Contractor will not receive payment until the certification is received by the Engineer. The certification shall be on WSDOT Form 350-109 provided by the Engineer, or such other form the Contractor chooses, provided it contains the same information as WSDOT Form 350-109.

Manufactured Products

Due to a nationwide waiver, BABA requirements do not apply to manufactured products. Manufactured products that contain steel and iron, regardless of a nationwide waiver, will follow “Steel and Iron Requirements” of this Specification.

Construction Material Requirements

A Contractor provided certification of materials origin will be required before each progress estimate or payment. The Contractor will not receive payment until the certification is received by the Engineer. The Contractor shall certify that all construction materials installed during the current progress estimate period meets the Build America, Buy America Act. The certification shall be on WSDOT Form 350-111 provided by the Engineer, or such other form the Contractor chooses, provided it contains the same information as WSDOT Form 350-111.

Waiver for De Minimis Costs

Minor amounts of Foreign Construction Materials may be utilized in this project, provided that the total cost of the Foreign Construction Materials does not exceed \$1,000,000 and does not exceed 5 percent of the total applicable material costs calculated as follows:

$$\frac{\textit{Total cost of Foreign Construction Materials}}{\textit{Total applicable material costs}} < 0.05$$

The total applicable material costs shall be the sum of the costs all Construction Materials, all Steel and Iron, and all Manufactured Products. Total applicable material costs does not include the cost of cement and cementitious materials; aggregates such as stone, sand, or gravel; or aggregate binding agents or additives.

Steel and iron materials shall follow the “Steel and Iron Requirements” of this Specification.

1-06.1(4) Fabrication Inspection Expense

Modification

(June 27, 2011 AWPA GSP)

Delete this section in its entirety.

1-06.2(2)B Financial Incentive

(January 4, 2024 AWPA GSP)

Replace the first sentence of this Section with the following:

The maximum Composite Pay Factor shall be 1.00.

1-06.6 Recycled Materials

Modification

(January 4, 2016 APWA GSP)

Delete this section, including its subsections, and replace it with the following:

The Contractor shall make their best effort to utilize recycled materials in the construction of the project. Approval of such material use shall be as detailed elsewhere in the Standard Specifications.

Prior to Physical Completion the Contractor shall report the quantity of recycled materials that were utilized in the construction of the project for each of the items listed in Section 9-03.21. The report shall include hot mix asphalt, recycled concrete aggregate, recycled glass, steel furnace slag and other recycled materials (e.g. utilization of on-site material and aggregates from concrete returned to the supplier). The Contractor’s report shall be provided on DOT form 350-075 Recycled Materials Reporting.

1-07 LEGAL RELATIONS AND RESPONSIBILITIES TO THE PUBLIC**1-07.1 Laws to be Observed***Supplement**(October 1, 2005 APWA GSP)*

Supplement this section with the following:

In cases of conflict between different safety regulations, the more stringent regulation shall apply.

The Washington State Department of Labor and Industries shall be the sole and paramount administrative agency responsible for the administration of the provisions of the Washington Industrial Safety and Health Act of 1973 (WISHA).

The Contractor shall maintain at the project site office, or other well known place at the project site, all articles necessary for providing first aid to the injured. The Contractor shall establish, publish, and make known to all employees, procedures for ensuring immediate removal to a hospital, or doctor's care, persons, including employees, who may have been injured on the project site. Employees should not be permitted to work on the project site before the Contractor has established and made known procedures for removal of injured persons to a hospital or a doctor's care.

The Contractor shall have sole responsibility for the safety, efficiency, and adequacy of the Contractor's plant, appliances, and methods, and for any damage or injury resulting from their failure, or improper maintenance, use, or operation. The Contractor shall be solely and completely responsible for the conditions of the project site, including safety for all persons and property in the performance of the work. This requirement shall apply continuously, and not be limited to normal working hours. The required or implied duty of the Engineer to conduct construction review of the Contractor's performance does not, and shall not, be intended to include review and adequacy of the Contractor's safety measures in, on, or near the project site.

1-07.1(2) Health and Safety*Supplement**(April 3, 2006 WSDOT GSP, Option 1)*

Section 1-07.1(2) is supplemented with the following:

Confined Space Confined spaces are known to exist at the following locations:

sanitary sewer manholes

The Contractor shall be fully responsible for the safety and health of all on-site workers and compliant with Washington Administrative Code (WAC 296-809).

The Contractor shall prepare and implement a confined space program for each of the confined spaces identified above. The Contractors Confined Space program shall be sent to the contracting agency at least 30 days prior to the Contractor beginning work in or adjacent to the confined space. No work shall be performed in or adjacent to the confined

space until the plan is submitted to the Engineer as required. The Contractor shall communicate with the Engineer to ensure a coordinated effort for providing and maintaining a safe worksite for both the Contracting Agency's and Contractor's workers when working in or near a confined space.

All costs to prepare and implement the confined space program shall be included in the bid prices for the various items associated with the confined space work.

1-07.2 State Taxes

Replacement

Delete this section, including its sub-sections, in its entirety and replace it with the following:

1-07.2 State Sales Tax

(June 27, 2011 APWA GSP)

The Washington State Department of Revenue has issued special rules on the State sales tax. Sections 1-07.2(1) through 1-07.2(3) are meant to clarify those rules. The Contractor should contact the Washington State Department of Revenue for answers to questions in this area. The Contracting Agency will not adjust its payment if the Contractor bases a bid on a misunderstood tax liability.

The Contractor shall include all Contractor-paid taxes in the unit bid prices or other contract amounts. In some cases, however, state retail sales tax will not be included. Section 1-07.2(2) describes this exception.

The Contracting Agency will pay the retained percentage (or release the Contract Bond if a FHWA-funded Project) only if the Contractor has obtained from the Washington State Department of Revenue a certificate showing that all contract-related taxes have been paid (RCW 60.28.051). The Contracting Agency may deduct from its payments to the Contractor any amount the Contractor may owe the Washington State Department of Revenue, whether the amount owed relates to this contract or not. Any amount so deducted will be paid into the proper State fund.

1-07.2(1) State Sales Tax — Rule 171

WAC 458-20-171, and its related rules, apply to building, repairing, or improving streets, roads, etc., which are owned by a municipal corporation, or political subdivision of the state, or by the United States, and which are used primarily for foot or vehicular traffic. This includes storm or combined sewer systems within and included as a part of the street or road drainage system and power lines when such are part of the roadway lighting system. For work performed in such cases, the Contractor shall include Washington State Retail Sales Taxes in the various unit bid item prices, or other contract amounts, including those that the Contractor pays on the purchase of the materials, equipment, or supplies used or consumed in doing the work.

1-07.2(2) State Sales Tax — Rule 170

WAC 458-20-170, and its related rules, apply to the constructing and repairing of new or existing buildings, or other structures, upon real property. This includes, but is not limited

to, the construction of streets, roads, highways, etc., owned by the state of Washington; water mains and their appurtenances; sanitary sewers and sewage disposal systems unless such sewers and disposal systems are within, and a part of, a street or road drainage system; telephone, telegraph, electrical power distribution lines, or other conduits or lines in or above streets or roads, unless such power lines become a part of a street or road lighting system; and installing or attaching of any article of tangible personal property in or to real property, whether or not such personal property becomes a part of the realty by virtue of installation.

For work performed in such cases, the Contractor shall collect from the Contracting Agency, retail sales tax on the full contract price. The Contracting Agency will automatically add this sales tax to each payment to the Contractor. For this reason, the Contractor shall not include the retail sales tax in the unit bid item prices, or in any other contract amount subject to Rule 170, with the following exception.

Exception: The Contracting Agency will not add in sales tax for a payment the Contractor or a subcontractor makes on the purchase or rental of tools, machinery, equipment, or consumable supplies not integrated into the project. Such sales taxes shall be included in the unit bid item prices or in any other contract amount.

1-07.2(3) Services

The Contractor shall not collect retail sales tax from the Contracting Agency on any contract wholly for professional or other services (as defined in Washington State Department of Revenue Rules 138 and 244).

1-07.7 Load Limits

Supplement

(March 13, 1995 WSDOT GSP, Option 6)

Section 1-07.7 is supplemented with the following:

If the sources of materials provided by the Contractor necessitates hauling over roads other than State Highways, the Contractor shall, at the Contractor's expense, make all arrangements for the use of the haul routes.

1-07.9 Wages

1-07.9(1) General

Supplement

(January 10, 2024, WSDOT GSP, Option 1)

Section 1-07.9(1) is supplemented with the following:

The Federal wage rates incorporated in this contract have been established by the Secretary of Labor under United States Department of Labor General Decision No. **WA20240001**.

The State rates incorporated in this contract are applicable to all construction activities associated with this contract.

1-07.9(5)A Required Documents

Modification

(July 8, 2024 APWA GSP)

This section is revised to read as follows:

All Statements of Intent to Pay Prevailing Wages, Affidavits of Wages Paid and Certified Payrolls, including a signed Statement of Compliance for Federal-aid projects, shall be submitted to the Engineer and to the State L&I online Prevailing Wage Intent & Affidavit (PWIA) system. When apprenticeship is a requirement of the contract, include in PWIA all apprentices.

1-07.11 Requirements for Nondiscrimination

Supplement

(October 3, 2024, APWA GSP Option B)

Section 1-07.11 is supplemented with the following:

Requirement for Affirmative Action to Ensure Equal Employment Opportunity (Executive Order 11246)

1. The Contractor's attention is called to the Equal Opportunity Clause and the Standard Federal Equal Employment Opportunity Construction Contract Specifications set forth herein.
2. The goals and timetables for minority and female participation set by the Office of Federal Contract Compliance Programs, expressed in percentage terms for the Contractor's aggregate work force in each construction craft and in each trade on all construction work in the covered area, are as follows:

Women - Statewide

<u>Timetable</u>	<u>Goal</u>
Until further notice	6.9%
<u>Minorities - by Standard Metropolitan Statistical Area (SMSA)</u>	
Spokane, WA:	
SMSA Counties:	
Spokane, WA	2.8
WA Spokane.	
Non-SMSA Counties	3.0
WA Adams; WA Asotin; WA Columbia; WA Ferry; WA Garfield; WA Lincoln, WA Pend Oreille; WA Stevens; WA Whitman.	
Richland, WA	
SMSA Counties:	
Richland Kennewick, WA	5.4

WA Benton; WA Franklin. Non-SMSA Counties WA Walla Walla.	3.6
Yakima, WA:	
SMSA Counties:	
Yakima, WA WA Yakima.	9.7
Non-SMSA Counties WA Chelan; WA Douglas; WA Grant; WA Kittitas; WA Okanogan.	7.2
Seattle, WA:	
SMSA Counties:	
Seattle Everett, WA WA King; WA Snohomish.	7.2
Tacoma, WA WA Pierce.	6.2
Non-SMSA Counties WA Clallam; WA Grays Harbor; WA Island; WA Jefferson; WA Kitsap; WA Lewis; WA Mason; WA Pacific; WA San Juan; WA Skagit; WA Thurston; WA Whatcom.	6.1
Portland, OR:	
SMSA Counties:	
Portland, OR-WA WA Clark.	4.5
Non-SMSA Counties WA Cowlitz; WA Klickitat; WA Skamania; WA Wahkiakum.	3.8

These goals are applicable to each nonexempt Contractor’s total on-site construction workforce, regardless of whether or not part of that workforce is performing work on a Federal, or federally assisted project, contract, or subcontract until further notice. Compliance with these goals and time tables is enforced by the Office of Federal Contract compliance Programs.

The Contractor’s compliance with the Executive Order and the regulations in 41 CFR Part 60-4 shall be based on its implementation of the Equal Opportunity Clause, specific affirmative action obligations required by the specifications set forth in 41 CFR 60-4.3(a), and its efforts to meet the goals. The hours of minority and female employment and training must be substantially uniform throughout the length of the contract, in each construction craft and in each trade, and the Contractor shall make a good faith effort to employ minorities and women evenly on each of its projects. The transfer of minority or female employees or trainees from Contractor to Contractor or from project to project for the sole purpose of meeting the Contractor’s goal shall be a violation of the contract, the Executive Order and the regulations in 41 CFR Part 60-4. Compliance with the goals will be measured against the total work hours performed.

3. The Contractor shall provide written notification to the Office of Federal Contract Compliance Programs (OFCCP) within 10 working days of award of any construction subcontract in excess of \$10,000 or more that are Federally funded, at any tier for construction work under the contract resulting from this solicitation. The notification

shall list the name, address and telephone number of the subcontractor; employer identification number of the subcontractor; estimated dollar amount of the subcontract; estimated starting and completion dates of the subcontract; and the geographical area in which the contract is to be performed. The notification shall be sent to:

U.S. Department of Labor
Office of Federal Contract Compliance Programs Pacific Region
Attn: Regional Director
San Francisco Federal Building
90 – 7th Street, Suite 18-300
San Francisco, CA 94103
(415) 625-7800 Phone
(415) 625-7799 Fax

4. As used in this Notice, and in the contract resulting from this solicitation, the Covered Area is as designated herein.

Standard Federal Equal Employment Opportunity Construction Contract Specifications (Executive Order 11246)

1. As used in these specifications:

- a. Covered Area means the geographical area described in the solicitation from which this contract resulted;
- b. Director means Director, Office of Federal Contract Compliance Programs, United States Department of Labor, or any person to whom the Director delegates authority;
- c. Employer Identification Number means the Federal Social Security number used on the Employer's Quarterly Federal Tax Return, U. S. Treasury Department Form 941;
- d. Minority includes:
 - (1) Black, a person having origins in any of the Black Racial Groups of Africa.
 - (2) Hispanic, a fluent Spanish speaking, Spanish surnamed person of Mexican, Puerto Rican, Cuban, Central American, South American, or other Spanish origin.
 - (3) Asian or Pacific Islander, a person having origins in any of the original peoples of the Pacific rim or the Pacific Islands, the Hawaiian Islands and Samoa.
 - (4) American Indian or Alaskan Native, a person having origins in any of the original peoples of North America, and who maintain cultural identification through tribal affiliation or community recognition.

2. Whenever the Contractor, or any subcontractor at any tier, subcontracts a portion of the work involving any construction trade, it shall physically include in each subcontract in excess of \$10,000 the provisions of these specifications and the Notice which contains the applicable goals for minority and female participation and which is set forth in the solicitations from which this contract resulted.
3. If the Contractor is participating (pursuant to 41 CFR 60-4.5) in a Hometown Plan approved by the U.S. Department of Labor in the covered area either individually or through an association, its affirmative action obligations on all work in the Plan area (including goals and timetables) shall be in accordance with that Plan for those trades which have unions participating in the Plan. Contractors must be able to demonstrate their participation in and compliance with the provisions of any such Hometown Plan. Each Contractor or subcontractor participating in an approved Plan is individually required to comply with its obligations under the EEO clause, and to make a good faith effort to achieve each goal under the Plan in each trade in which it has employees. The overall good faith performance by other Contractors or subcontractors toward a goal in an approved Plan does not excuse any covered Contractor's or subcontractor's failure to take good faith effort to achieve the Plan goals and timetables.
4. The Contractor shall implement the specific affirmative action standards provided in paragraphs 7a through 7p of this Special Provision. The goals set forth in the solicitation from which this contract resulted are expressed as percentages of the total hours of employment and training of minority and female utilization the Contractor should reasonably be able to achieve in each construction trade in which it has employees in the covered area. Covered construction contractors performing construction work in geographical areas where they do not have a Federal or federally assisted construction contract shall apply the minority and female goals established for the geographical area where the work is being performed. The Contractor is expected to make substantially uniform progress in meeting its goals in each craft during the period specified.
5. Neither the provisions of any collective bargaining agreement, nor the failure by a union with whom the Contractor has a collective bargaining agreement, to refer either minorities or women shall excuse the Contractor's obligations under these specifications, Executive Order 11246, or the regulations promulgated pursuant thereto.
6. In order for the nonworking training hours of apprentices and trainees to be counted in meeting the goals, such apprentices and trainees must be employed by the Contractor during the training period, and the Contractor must have made a commitment to employ the apprentices and trainees at the completion of their training, subject to the availability of employment opportunities. Trainees must be trained pursuant to training programs approved by the U.S. Department of Labor.
7. The Contractor shall take specific affirmative actions to ensure equal employment opportunity. The evaluation of the Contractor's compliance with these specifications shall be based upon its effort to achieve maximum results from its action. The Contractor shall document these efforts fully, and shall implement affirmative action steps at least as extensive as the following:

- a. Ensure and maintain a working environment free of harassment, intimidation, and coercion at all sites, and in all facilities at which the Contractor's employees are assigned to work. The Contractor, where possible, will assign two or more women to each construction project. The Contractor shall specifically ensure that all foremen, superintendents, and other on-site supervisory personnel are aware of and carry out the Contractor's obligation to maintain such a working environment, with specific attention to minority or female individuals working at such sites or in such facilities.
- b. Establish and maintain a current list of minority and female recruitment sources, provide written notification to minority and female recruitment sources and to community organizations when the Contractor or its unions have employment opportunities available, and maintain a record of the organizations' responses.
- c. Maintain a current file of the names, addresses and telephone numbers of each minority and female off-the-street applicant and minority or female referral from a union, a recruitment source or community organization and of what action was taken with respect to each such individual. If such individual was sent to the union hiring hall for referral and was not referred back to the Contractor by the union or, if referred, not employed by the Contractor, this shall be documented in the file with the reason therefor, along with whatever additional actions the Contractor may have taken.
- d. Provide immediate written notification to the Director when the union or unions with which the Contractor has a collective bargaining agreement has not referred to the Contractor a minority person or woman sent by the Contractor, or when the Contractor has other information that the union referral process has impeded the Contractor's efforts to meet its obligations.
- e. Develop on-the-job training opportunity and/or participate in training programs for the area which expressly include minorities and women, including upgrading programs and apprenticeship and trainee programs relevant to the Contractor's employment needs, especially those programs funded or approved by the U.S. Department of Labor. The Contractor shall provide notice of these programs to the sources compiled under 7b above.
- f. Disseminate the Contractor's EEO policy by providing notice of the policy to unions and training programs and requesting their cooperation in assisting the Contractor in meeting its EEO obligations; by including it in any policy manual and collective bargaining agreement; by publicizing it in the company newspaper, annual report, etc.; by specific review of the policy with all management personnel and with all minority and female employees at least once a year; and by posting the company EEO policy on bulletin boards accessible to all employees at each location where construction work is performed.
- g. Review, at least annually, the company's EEO policy and affirmative action obligations under these specifications with all employees having any

responsibility for hiring, assignment, layoff, termination or other employment decisions including specific review of these items with on-site supervisory personnel such as Superintendents, General Foremen, etc., prior to the initiation of construction work at any job site. A written record shall be made and maintained identifying the time and place of these meetings, persons attending, subject matter discussed, and disposition of the subject matter.

- h. Disseminate the Contractor's EEO policy externally by including it in any advertising in the news media, specifically including minority and female news media, and providing written notification to and discussing the Contractor's EEO policy with other Contractors and Subcontractors with whom the Contractor does or anticipates doing business.
- i. Direct its recruitment efforts, both oral and written to minority, female and community organizations, to schools with minority and female students and to minority and female recruitment and training organizations serving the Contractor's recruitment area and employment needs. Not later than one month prior to the date for the acceptance of applications for apprenticeship or other training by any recruitment source, the Contractor shall send written notification to organizations such as the above, describing the openings, screening procedures, and tests to be used in the selection process.
- j. Encourage present minority and female employees to recruit other minority persons and women and where reasonable, provide after school, summer and vacation employment to minority and female youth both on the site and in other areas of a Contractor's work force.
- k. Validate all tests and other selection requirements where there is an obligation to do so under 41 CFR Part 60-3.
- l. Conduct, at least annually, an inventory and evaluation of all minority and female personnel for promotional opportunities and encourage these employees to seek or to prepare for, through appropriate training, etc., such opportunities.
- m. Ensure that seniority practices, job classifications, work assignments and other personnel practices, do not have a discriminatory effect by continually monitoring all personnel and employment related activities to ensure that the EEO policy and the Contractor's obligations under these specifications are being carried out.
- n. Ensure that all facilities and company activities are nonsegregated except that separate or single-user toilet and necessary changing facilities shall be provided to assure privacy between the sexes.
- o. Document and maintain a record of all solicitations of offers for subcontracts from minority and female construction contractors and suppliers, including circulation of solicitations to minority and female contractor associations and other business associations.

- p. Conduct a review, at least annually, of all supervisors' adherence to and performance under the Contractor's EEO policies and affirmative action obligations.
8. Contractors are encouraged to participate in voluntary associations which assist in fulfilling one or more of their affirmative action obligations (7a through 7p). The efforts of a contractor association, joint contractor-union, contractor-community, or other similar group of which the Contractor is a member and participant, may be asserted as fulfilling any one or more of the obligations under 7a through 7p of this Special Provision provided that the Contractor actively participates in the group, makes every effort to assure that the group has a positive impact on the employment of minorities and women in the industry, ensure that the concrete benefits of the program are reflected in the Contractor's minority and female work-force participation, makes a good faith effort to meet its individual goals and timetables, and can provide access to documentation which demonstrate the effectiveness of actions taken on behalf of the Contractor. The obligation to comply, however, is the Contractor's and failure of such a group to fulfill an obligation shall not be a defense for the Contractor's noncompliance
9. A single goal for minorities and a separate single goal for women have been established. The Contractor, however, is required to provide equal employment opportunity and to take affirmative action for all minority groups, both male and female, and all women, both minority and non-minority. Consequently, the Contractor may be in violation of the Executive Order if a particular group is employed in substantially disparate manner (for example, even though the Contractor has achieved its goals for women generally, the Contractor may be in violation of the Executive Order if a specific minority group of women is underutilized).
10. The Contractor shall not use the goals and timetables or affirmative action standards to discriminate against any person because of race, color, religion, sex, or national origin.
11. The Contractor shall not enter into any subcontract with any person or firm debarred from Government contracts pursuant to Executive Order 11246.
12. The Contractor shall carry out such sanctions and penalties for violation of these specifications and of the Equal Opportunity Clause, including suspensions, terminations and cancellations of existing subcontracts as may be imposed or ordered pursuant to Executive Order 11246, as amended, and its implementing regulations by the Office of Federal Contract Compliance Programs. Any Contractor who fails to carry out such sanctions and penalties shall be in violation of these specifications and Executive Order 11246, as amended.
13. The Contractor, in fulfilling its obligations under these specifications, shall implement specific affirmative action steps, at least as extensive as those standards prescribed in paragraph 7 of this Special Provision, so as to achieve maximum results from its efforts to ensure equal employment opportunity. If the Contractor fails to comply with the requirements of the Executive Order, the implementing regulations, or these specifications, the Director shall proceed in accordance with 41 CFR 60-4.8.

14. The Contractor shall designate a responsible official to monitor all employment related activity to ensure that the company EEO policy is being carried out, to submit reports relating to the provisions hereof as may be required by the government and to keep records. Records shall at least include, for each employee, their name, address, telephone numbers, construction trade, union affiliation if any, employee identification number when assigned, social security number, race, sex, status (e.g., mechanic, apprentice, trainee, helper, or laborer), dates of changes in status, hours worked per week in the indicated trade, rate of pay, and locations at which the work was performed. Records shall be maintained in an easily understandable and retrievable form; however, to the degree that existing records satisfy this requirement, the Contractors will not be required to maintain separate records.
15. Nothing herein provided shall be construed as a limitation upon the application of other laws which establish different standards of compliance or upon the application of requirements for the hiring of local or other area residents (e.g., those under the Public Works Employment Act of 1977 and the Community Development Block Grant Program).
16. Additional assistance for Federal Construction Contractors on contracts administered by Washington State Department of Transportation or by Local Agencies may be found at:

Washington State Dept. of Transportation
Office of Equal Opportunity
PO Box 47314
310 Maple Park Ave. SE
Olympia WA
98504-7314
Ph: 360-705-7090
Fax:360-705-6801
<http://www.wsdot.wa.gov/equalopportunity/default.htm>

(September 3, APWA GSP, Option B)

Section 1-07.11 is supplemented with the following:

Disadvantaged Business Enterprise Participation

General

The Disadvantaged Business Enterprise (DBE) requirements of 49 CFR Part 26 and USDOT's official interpretations (i.e., Questions & Answers) apply to this Contract. Demonstrating compliance with these Specifications is a Condition of Award (COA) of this Contract. Failure to comply with the requirements of this Specification may result in your Bid being found to be irregular in accordance with Section 1-02.13 resulting in rejection or other sanctions as provided by the Contract.

DBE Abbreviations and Definitions

Certified Business Description – The approved business description that supplements the North American Industry Classification System (NAICS) code listed in OMWBE's directory of certified firms.

Certified Business Directory – A database of all Minority, Women, and Disadvantaged Business Enterprises currently certified by Washington State. The on-line Directory is available to Bidders for their use in identifying and soliciting interest from DBE firms. The database is located under the Firm Certification section of the Diversity Management and Compliance System web page at: <https://omwbe.diversitycompliance.com>.

Commercially Useful Function (CUF) –

A firm performs a commercially useful function when it is responsible for execution of the work of the contract and is carrying out its responsibilities by performing, managing, and supervising the work involved as defined in 49 CFR 26.55(c)(1). To perform a commercially useful function, the firm must also be responsible, with respect to materials and supplies used on the contract, for ordering, negotiating price, paying for, determining quality and quantity, and installing (where applicable) for the material itself.

The DBE firm does not perform a CUF if its role is limited to that of an extra participant in a transaction, contract, or Project through which the funds are passed to obtain the appearance of DBE participation.

Consultant, DBE – An individual, partnership, firm, or corporation who meet the definition of a DBE which has been retained under a contract to provide technical or professional services.

DBE Commitment – The dollar amount and scope of work the Bidder indicates on each line of their DBE Utilization Certification (DOT Form 272-056) for each DBE firm. These Commitments will be incorporated into the Contract and shall be considered Contract requirements.

DBE Condition of Award (COA) Goal – An assigned numerical amount specified as a percentage of the Contract. At Bid, this is the minimum amount that the Bidder must commit to by submission of the DBE Utilization Certification form and, if necessary, by GFE Documentation.

Disadvantaged Business Enterprise (DBE) – A business that is owned and operated independently from other businesses and is certified by the Washington State Office of Minority and Women’s Business Enterprises, as meeting the criteria outlined in 49 CFR 26 regarding DBE certification.

Force Account Work – Work measured and paid in accordance with Section 1-09.6.

Good Faith Efforts (GFE) – Efforts to achieve the DBE COA Goal or other requirements of this Provision which, by their scope, intensity, and appropriateness to the objective, can reasonably be expected to fulfill the program requirement.

Good Faith Efforts (GFE) Documentation - The documentation of the Good Faith Effort. GFE Documentation is only required in the event that the Contractor is unable to fulfill the program requirements and shall follow the guidance of 49 CFR Part 26 Appendix A.

Subcontractor, DBE – An individual, partnership, firm, corporation, or joint venture who meet the definition of a DBE and who is sublet part of the Contract.

Supplier, DBE – A Manufacturer, Regular Dealer, Distributor, or Transaction Facilitator who provides supplies or materials for the Contract. The role a Supplier performs is determined on a contract-by contract basis.

Manufacturer, DBE – A DBE firm that operates or maintains a factory or establishment that produces on the premises the materials, supplies, articles, or equipment required under the Contract. A DBE Manufacturer shall produce finished goods or products from raw or unfinished material or purchase and substantially alters goods and materials to make them suitable for construction use before reselling them.

Regular Dealer, DBE – A DBE firm that owns, operates, or maintains a store, warehouse, or other establishment in which the materials or supplies required for the performance of a Contract are bought, kept in stock, and regularly sold to the public in the usual course of business. To be a Regular Dealer, the DBE firm must be an established regular business that engages in as its principal business and in its own name the purchase and sale of the products in question. A Regular Dealer in such items as steel, cement, gravel, stone, and petroleum products need not own, operate or maintain a place of business if it both owns and operates distribution equipment for the products. Any supplementing of regular dealers’ own distribution equipment shall be by long-term formal lease agreements and not on an ad-hoc basis. Brokers, packagers, manufacturers’ representatives, or other persons who arrange or expedite transactions shall not be regarded as Regular Dealers within the meaning of this definition.

Distributor, DBE –An established DBE firm that engages in the regular sale or lease of the items specified by the contract. A DBE Distributor assumes responsibility for the items it purchases once they leave the point of origin, making it liable for any loss or damage not covered by the carrier’s insurance. The Distributor must demonstrate ownership of the items in question and assure all risk for loss or damage during transportation, evidenced by the terms of the purchase order or bill of lading from a third party, indicating Free on Board (FOB) at the point of origin or similar terms that transfer responsibility of the items in question to the DBE distributors.

Transaction Facilitator, DBE – A DBE firm (packagers, brokers, manufacturer’s representatives, etc.) who provides a bona fide service arranging, facilitating, or expediting transactions but does not qualify as a Manufacturer, a Regular Dealer, or a Distributor

DBE COA Goal

The Contracting Agency has established a DBE COA Goal for this Contract in the amount of: 17% which applies to the final Contract amount.

If the Contractor cannot meet the DBE COA Goal, GFE Documentation is required.

Demonstrating compliance with the DBE COA Goal is a Condition of Award of this Contract.

Procedures Prior to Award

Approval of Regular Dealer and Distributors

DBE firms proposed to be used as either a Regular Dealer or a Distributor must be approved before being listed as a COA/used on a project. The Approved Regular Dealer list published on WSDOT’s Office of Equity and Civil Rights (OECR) web site must include the specific project for which approval is being requested. For purposes of the DBE COA Goal participation, the Regular Dealer/Distributor must submit the DBE Regular Dealer/Distributor Affirmation Form (USDOT OMB Control 508v3) a minimum of five calendar days prior to bid opening. The DBE Regular Dealer/Distributor Affirmation Form is located at:
<https://www.transportation.gov/mission/civil-rights/dbe-regular-dealer-distributor-affirmation>

Requests to be listed as a Regular Dealer/Distributor will only be processed if the requesting firm is a material supplier certified by the Office of Minority and Women’s Business Enterprises in a NAICS code that falls within the 42XXXX NAICS Wholesale code section.

Disadvantaged Business Enterprise Utilization

To be eligible for award of the Contract, the Bidder shall properly complete and submit a Disadvantaged Business Enterprise (DBE) Utilization Certification with the Bidder’s sealed Bid Proposal, as specified in Section 1-02.9 Delivery of Proposal. The Bidder’s DBE Utilization Certification must clearly demonstrate how the Bidder intends to meet the DBE COA Goal. A DBE Utilization Certification (WSDOT Form 272-056) is included in the Proposal package for this purpose as well as instructions on how to properly fill out the form.

The Bidder is advised that the items listed below when listed in the Utilization Certification must have their amounts reduced to the percentages shown and those reduced amounts will be the amount applied towards meeting the DBE COA Goal.

1. Force account at 50% of the total amount to be subcontracted
2. Regular dealer at 60% of the cost of the materials or supplies
3. Distributor at 40% of the cost of the materials or supplies
4. Transaction Facilitator not more than 5% of the goods or services

In the event of arithmetic errors in completing the DBE Utilization Certification, the amount listed to be applied towards the DBE COA Goal for each DBE shall govern and the DBE total amount shall be adjusted accordingly.

Bid Proposals submitted that do not contain a DBE Utilization Certification Form that demonstrates how the Bidder intends to meet the DBE COA Goal will be considered irregular in accordance with Section make the Proposal considered to be irregular in accordance with Section 1-02.13 and will be rejected.

Disadvantaged Business Enterprise Written Confirmation Document(s)

The Bidder shall submit a Disadvantaged Business Enterprise (DBE) Written Confirmation Document (completed and signed by the DBE) for each DBE firm listed in the Bidder's completed DBE Utilization Certification. Failure to do so will result in the associated participation being disallowed, which will cause the Bid to be considered irregular in accordance with Section 1-02.13 and will be rejected.

The Confirmation Documents provide confirmation from the DBEs that they are participating in the Contract as provided in the Bidder's Commitment. The Confirmation Documents must be consistent with the Utilization Certification.

A DBE Written Confirmation Document (WSDOT Form 422-031) is included in the Proposal package for this purpose. The form(s) shall be received as specified in the special provisions for Section 1-02.9 Delivery of Proposal.

It is prohibited for the Bidder to require a DBE to submit a Written Confirmation Document with any part of the form left blank. Should the Contracting Agency determine that an incomplete Written Confirmation Document was signed by a DBE, the associated DBE participation may not be allowed.

DBE Bid Item Breakdown

The Bidder shall submit a DBE Bid Item Breakdown Form (DOT Form 272-054) as specified in the Special Provisions for Section 1-02.9, Delivery of Proposal.

Selection of Successful Bidder/Good Faith Efforts (GFE)

The successful Bidder shall be selected on the basis of having submitted the lowest responsive Bid, which demonstrates a good faith effort to achieve the DBE COA Goal. The Contracting Agency, at any time during the selection process, may request a breakdown of the bid items and amounts that are counted towards the overall contract goal for any of the DBEs listed on the DBE Utilization Certification.

GFE to achieve the DBE COA Goal may be accomplished in one of two ways:

1. By meeting the DBE COA Goal
Submission of the DBE Utilization Certification, supporting DBE Written Confirmation Document(s) showing the Bidder has obtained enough DBE participation to meet or exceed the DBE COA Goal and the DBE Bid Item Breakdown
2. By documentation that the Bidder made adequate GFE to meet the DBE COA Goal
The Bidder may demonstrate a GFE in whole or part through GFE Documentation only in the event a Bidder's efforts to solicit sufficient DBE participation have been unsuccessful. The Bidder must supply GFE Documentation in addition to the DBE Utilization Certification, supporting DBE Written Confirmation Document(s) and the DBE Bid Item Breakdown form.

In the case where a Bidder is awarded the contract based on demonstrating adequate GFE Documentation, the advertised DBE COA Goal will not be reduced. The Bidder shall demonstrate a GFE during the life of the Contract to attain the advertised DBE COA Goal.

The Contracting Agency will review the GFE Documentation and will determine if the Bidder made an adequate good faith effort.

Procedures between Award and Execution

DBE Trucking Credit Form

The successful Bidder shall submit a DBE Trucking Credit Form (WSDOT Form 272-058), as specified in the Special Provisions for Section 1-03.3, Execution of Contract.

The DBE Trucking Credit Form is required for all DBE Firms performing as a subcontractor for "Trucking" or "Hauling" and are performing a part of a bid item. For example, if the item of Work is Structure Excavation including Haul, and another firm is doing the excavation and the DBE Trucking firm is doing the haul, the form is required. For a DBE subcontractor that is responsible for an entire item of work that may require some use of trucks, the form is not required.

Procedures after Execution

Commercially Useful Function (CUF)

The Contractor may only take credit for the payments made for Work performed by a DBE that is determined to be performing a CUF. Payment must be commensurate with the work actually performed by the DBE. This applies to all DBEs performing Work on a project, whether or not the DBEs are COA, if the Contractor wants to receive credit for their participation. The Engineer will conduct CUF reviews to ascertain whether DBEs are performing a CUF. A DBE performs a CUF when it is carrying out its responsibilities of its contract by actually performing, managing, and supervising the Work involved. The DBE must be responsible for negotiating price; determining quality and quantity; ordering the material, installing (where applicable); and paying for the material itself. If a DBE does not perform "all" of these functions on a furnish-and-install contract, it has not performed a CUF and the cost of materials cannot be counted toward DBE COA Goal. Leasing of equipment from a leasing

company is allowed. However, leasing/purchasing equipment from the Contractor is not allowed. Lease agreements shall be provided prior to the subcontractor beginning Work. Any use of the Contractor's equipment by a DBE will not be credited as countable participation.

The DBE does not perform a CUF if its role is limited to that of an extra participant in a transaction, contract, or project through which the funds are passed in order to obtain the appearance of DBE participation.

In order for a DBE traffic control company to be considered to be performing a CUF, the DBE must be in control of its work inclusive of supervision. The DBE shall employ a Traffic Control Supervisor who is directly involved in the management and supervision of the traffic control employees and services.

The following are some of the factors that the Engineer will use in determining whether a DBE trucking company is performing a CUF:

1. The DBE shall be responsible for the management and supervision of the entire trucking operation for which it is responsible on the contract. The owner demonstrates business related knowledge, shows up on site and is determined to be actively running the business.
2. The DBE itself shall own and operate at least one fully licensed, insured, and operational truck used on the Contract. The drivers of the trucks owned and leased by the DBE must be exclusively employed by the DBE and reflected on the DBE's payroll.
3. Lease agreements for trucks shall indicate that the DBE has exclusive use of and control over the truck(s). This does not preclude the leased truck from working for others provided it is with the consent of the DBE and the lease provides the DBE absolute priority for use of the leased truck.
4. Leased trucks shall display the name and identification number of the DBE.

Truck Unit Listing Log

In addition to the subcontracting requirements of Section 1-08.1, each DBE trucking firm shall submit supplemental information consisting of a completed primary DBE/FSBE Truck Unit Listing Log (DOT Form 350-077) and all Rental/Lease agreements (if applicable). The supplemental information shall be submitted in an electronic format to the Engineer prior to any trucking services being performed for DBE credit. Incomplete or incorrect supplemental information will be returned for correction. The corrected Primary Truck Unit Listing Log and any Updated Primary Truck Unit Listing Logs shall be submitted and accepted by the Engineer no later than ten calendar days of utilizing applicable trucks. Failure to submit or update the DBE Truck Unit Listing Log may result in trucks not being credited as DBE participation.

Each DBE trucking firm shall complete a daily DBE/FSBE Truck Unit Listing Log (DOT Form 350-077) for each day that the DBE performs trucking services for DBE credit. The Daily Truck Unit Listing Log forms shall be submitted by Friday of the week after the Work was performed by email to the following email addresses.

adobrovidova@cityoflakewood.us; ORegionOEO@wsdot.wa.gov

Joint Checking

A joint check is a check between a subcontractor and the Contractor to the supplier of materials/supplies. The check is issued by the Contractor as payer to the subcontractor and the material supplier jointly for items to be incorporated into the project. The DBE must release the check to the supplier, while the Contractor acts solely as the guarantor.

A joint check agreement must be approved by the Engineer and requested by the DBE involved using the DBE Joint Check Request Form (WSDOT Form 272-053) prior to its use. The form must accompany the DBE Joint Check Agreement between the parties involved, including the conditions of the arrangement and expected use of the joint checks.

The approval to use joint checks and the use will be closely monitored by the Engineer. To receive DBE credit for performing a CUF with respect to obtaining materials and supplies, a DBE must “be responsible for negotiating price, determining quality and quantity, ordering the material, installing and paying for the material itself.” The Contractor shall submit DBE Joint Check Request Form to the Engineer and be in receipt of written approval prior to using a joint check.

Material costs paid by the Contractor directly to the material supplier are not allowed. If proper procedures are not followed or the Engineer determines that the arrangement results in lack of independence for the DBE involved, no DBE credit will be given for the DBE’s participation as it relates to the material cost.

Prompt Payment

Prompt payment to all subcontractors shall be in accordance with Section 1-08.1. Prompt payment requirements apply to progress payments as well as return of retainage.

Reporting

The Contractor and all subcontractors of any tier, suppliers, service providers, and professional services that utilize DBEs to perform work on the project, shall maintain appropriate records that will enable the Engineer to verify DBE participation throughout the life of the project.

Refer to Section 1-08.1 for additional reporting requirements associated with this Contract.

Crediting DBE Participation

General

Subcontractors proposed as COA must be certified prior to the due date for bids on the Contract. All non-COA DBE subcontractors shall be certified before the subcontract on which they are participating is executed.

DBE participation is only credited upon payment to the DBE.

DBE Prime Contractor and Subcontractor Participation

Only take credit for the Work that the DBE contractor performs with its own forces and is certified to perform.

If the Prime Contractor, subcontractor, or lower tier subcontractor DBE subcontracts a portion of the Work of its contract to another firm, the value of the subcontracted Work may be counted toward the DBE Commitments only if the lower-tier subcontractor is also a DBE.

Work subcontracted to a lower-tier subcontractor that is a DBE may be counted toward the DBE Commitments only if the lower-tier subcontractor self performs a minimum of 30 percent of the Work subcontracted to them.

Work subcontracted by a DBE contractor to a non-DBE does not count towards the DBE COA Goal.

DBE Subcontract and Lower Tier Subcontract Documents**DBE Consultants**

A DBE firm providing a bona fide service, such as professional, technical, or managerial services, specifically required for the performance of the contract will be credited as DBE participation

Force Account Work

When the Bidder elects to utilize force account Work to meet the DBE COA Goal, as demonstrated by listing this force account Work on the DBE Utilization Certification form, for the purposes of meeting DBE COA Goal, only 50% of the Proposal amount shall be credited toward the Bidder's Commitment to meet the DBE COA Goal.

One hundred percent of the actual amounts paid to the DBE for the force account Work shall be credited towards the DBE COA Goal or DBE participation.

Temporary Traffic Control Participation

If the DBE firm only provides "Flagging", the DBE firm must provide a traffic control supervisor (TCS) and flagger(s), which are under the direct control of the DBE. The DBE firm shall also provide all flagging equipment for its employees (e.g., paddles, hard hats, and vests).

If the DBE firm provides "Traffic Control Services", the DBE firm must provide a TCS, flaggers, and traffic control items (e.g., cones, barrels, signs, etc.) and be in total control of all items in implementing the traffic control for the project.

Trucking Participation

DBE trucking firm participation may only be credited as DBE participation for the value of the hauling services, not for the materials being hauled unless the trucking firm is also certified as a supplier of those materials. In situations where the DBE's work is priced per ton, the value of the hauling service must be calculated separately from the value of the materials in order to determine DBE credit for hauling

The DBE trucking firm must own and operate at least one licensed, insured and operational truck on the contract. The truck must be of the type that is necessary to perform the hauling duties required under the contract. The DBE receives credit for the value of the transportation services it provides on the Contract using trucks it owns or leases, licenses, insures, and operates with drivers it employs.

The DBE may lease additional trucks from another DBE firm. The DBE who leases additional trucks from another DBE firm receives credit for the value of the transportation services the lessee DBE provides on the Contract.

The trucking Work subcontracted to any non-DBE trucking firm will not receive credit for Work done on the project.

The DBE may lease trucks from a truck leasing company (recognized truck rental center) but can only receive credit towards DBE participation if the DBE uses its own employees as drivers.

DBE Supplier

The credit of a DBE Supplier is decided on a contract-by-contract basis based on what the role the proposed DBE Supplier will be performing. OECR will make determinations on whether a Supplier qualifies as a Regular Dealer, Distributor, or Transaction Facilitator based on their role for the Contract.

Manufacturer - One hundred percent (100%) of the cost of the manufactured product obtained from a DBE manufacturer may count towards the DBE COA Goal.

Regular Dealer - Sixty percent (60%) of the cost of materials or supplies purchased from a DBE Regular Dealer may be credited toward the DBE Goal.
Distributor – Forty percent (40%) of the cost of materials or supplies purchased from a DBE Distributor may be credited toward the DBE Goal.

Transaction Facilitator - only the fees or commissions charged for assistance in the procurement of the materials and supplies, or fees or transportation charges for the delivery of materials or supplies required on the job site, may toward the DBE COA Goal provided the fees are not excessive as compared with fees customarily allowed for similar services. The reasonable fee shall not exceed 5 percent of the total cost of the goods or services. Documentation will be required to support the fee/commission charged by the DBE. The cost of the materials and supplies themselves cannot be counted toward the DBE Goal.

Changes in COA Work Committed to DBE

The Contractor shall utilize the COA DBEs to perform the work and supply the materials for which each is committed unless prior written approval by the Engineer has been received by the Contractor. The Contractor shall not be entitled to any payment for work or material completed by the Contractor or subcontractors that was committed to be completed by the COA DBEs in the DBE Utilization Certification form.

Changes

In the event a change results in a reduction to Work committed to a COA DBE, the Contractor shall substitute other remaining Work to that COA DBE if possible, to avoid a change to the total dollar amount to be applied towards the goal committed to that COA DBE. If there is a reduction to the total dollar amount to be applied towards the goal for a COA DBE Commitment, regardless of the reason, it shall be viewed as DBE termination, and subject to the termination procedures below. A notification to the DBE shall occur as soon as possible but no later than two weeks after the Contractor is aware of the upcoming change.

Original Quantity Underruns

In the event that Work committed to a DBE firm as part of the COA underruns the original planned quantities the Contractor may be required to substitute other remaining Work to another DBE.

Contractor Proposed DBE Substitutions

Requests to substitute a COA DBE must be for good cause (see DBE termination process below) and requires prior written approval of the Engineer. After receiving a termination with good cause approval, the Contractor may only replace a DBE with another certified DBE. When changes between Contract Award and Execution result in a substitution of COA DBE, the substitute DBE shall be certified prior to the bid opening on the Contract.

DBE Termination

Termination of a COA DBE (or an approved substitute DBE) is only allowed in whole or in part for good cause and with prior written approval of the Contracting Agency. If the Contractor terminates a COA DBE without the prior written approval of the Contracting Agency, the Contractor shall not be entitled to payment for work or material committed to, but not performed/supplied by the COA DBE. In addition, sanctions may apply as described elsewhere in this specification.

Prior to requesting approval to terminate a COA DBE, the Contractor shall give notice in writing to the DBE with a copy to the Engineer of its intent to request to terminate DBE Work and the reasons for doing so. The DBE shall have five days to respond to the Contractor's notice. The DBE's response shall either support the termination or advise the Engineer and the Contractor of the reasons it objects to the termination of its subcontract.

If the request for termination is approved, the Contractor is required to substitute with another DBE to perform at least the same amount of work as the DBE that was terminated (or provide GFE Documentation). A plan to replace the COA DBE Commitment amount shall be submitted to the Engineer within 2 days of the approval of termination. The plan to replace the Commitment shall provide the same detail as that required in the DBE Utilization Certification.

As mentioned above, the Contractor must have good cause to terminate a COA DBE.

Good cause typically includes situations where the DBE subcontractor is unable or unwilling to perform the work of its subcontract. Good cause may exist if:

1. The DBE fails or refuses to execute a written contract.
2. The DBE fails or refuses to perform the Work of its subcontract in a way consistent with normal industry standards.
3. The DBE fails or refuses to meet the Contractor's reasonable nondiscriminatory bond requirements.
4. The DBE becomes bankrupt, insolvent, or exhibits credit unworthiness.
5. The DBE is ineligible to work on public works projects because of suspension and debarment proceedings pursuant to federal law or applicable State law.
6. The DBE is ineligible to receive DBE credit for the type of work involved.
7. The DBE voluntarily withdraws from the project and provides written notice of its withdrawal.
8. The DBE's work is deemed unsatisfactory by the Engineer and not in compliance with the Contract.
9. The DBE's owner dies or becomes disabled with the result that the DBE is unable to complete its Work on the Contract.

Good cause does not exist if:

1. The Contractor seeks to terminate a COA DBE so that the Contractor can self-perform the Work.
2. The Contractor seeks to terminate a COA DBE so the Contractor can substitute another DBE contractor or non-DBE contractor after Contract Award.
3. The failure or refusal of the COA DBE to perform its Work on the subcontract results from the bad faith or discriminatory action of the Contractor (e.g., the failure of the Contractor to make timely payments or the unnecessary placing of obstacles in the path of the DBE's Work).

Decertification

When a DBE is "decertified" from the DBE program during the course of the Contract, the participation of that DBE shall continue to count as DBE participation as long as the subcontract with the DBE was executed prior to the decertification notice. The Contractor is obligated to substitute when a DBE does not have an executed subcontract agreement at the time of decertification.

Good Faith Effort (GFE) Documentation

GFE Documentation is required and will be evaluated whenever the Contractor is unable to fulfill the program requirement. This evaluation may need to be repeated when:

1. Determining award of a Contract that has COA goal,
2. When a COA DBE is terminated and substitution is required, and
3. Prior to Physical Completion when determining whether the Contractor has satisfied its DBE commitments.

49 CFR Part 26, Appendix A is intended as general guidance and does not, in itself, demonstrate adequate good faith efforts. The following is a list of types of actions, which would be considered as part of the Bidder's GFE Documentation to achieve DBE participation. It is not intended to be a mandatory checklist, nor is it intended to be exclusive or exhaustive. Other factors or types of efforts may be relevant in appropriate cases.

1. Soliciting through all reasonable and available means (e.g. attendance at pre-bid meetings, advertising and/or written notices) the interest of all certified DBEs who have the capability to perform the Work of the Contract. The Bidder must solicit this interest within sufficient time to allow the DBEs to respond to the solicitation. The Bidder must determine with certainty if the DBEs are interested by taking appropriate steps to follow up initial solicitations.
2. Selecting portions of the Work to be performed by DBEs in order to increase the likelihood that the DBE COA Goal will be achieved. This includes, where appropriate, breaking out contract Work items into economically feasible units to facilitate DBE participation, even when the Bidder might otherwise prefer to perform these Work items with its own forces.
3. Providing interested DBEs with adequate information about the Plans, Specifications, and requirements of the Contract in a timely manner to assist them in responding to a solicitation.
 - a. Negotiating in good faith with interested DBEs. It is the Bidder's responsibility to make a portion of the Work available to DBE subcontractors and suppliers and to select those portions of the Work or material needs consistent with the available DBE subcontractors and suppliers, so as to facilitate DBE participation. Evidence of such negotiation includes the names, addresses, and telephone numbers of DBEs that were considered; a description of the information provided regarding the Plans and Specifications for the Work selected for subcontracting; and evidence as to why additional agreements could not be reached for DBEs to perform the Work.
 - b. A Bidder using good business judgment would consider a number of factors in negotiating with subcontractors, including DBE subcontractors, and would take a firm's price and capabilities as well as the DBE COA

Goal into consideration. However, the fact that there may be some additional costs involved in finding and using DBEs is not in itself sufficient reason for a Bidder's failure to meet the DBE COA Goal, as long as such costs are reasonable. Also, the ability or desire of a Bidder to perform the Work of a Contract with its own organization does not relieve the Bidder of the responsibility to make Good Faith Efforts. Bidders are not, however, required to accept higher quotes from DBEs if the price difference is excessive or unreasonable.

4. Not rejecting DBEs as being unqualified without sound reasons based on a thorough investigation of their capabilities. The Bidder's standing within its industry, membership in specific groups, organizations, or associations and political or social affiliations (for example union vs. non-union employee status) are not legitimate causes for the rejection or non-solicitation of bids in the Bidder's efforts to meet the DBE COA Goal.
5. Making efforts to assist interested DBEs in obtaining bonding, lines of credit, or insurance as required by the recipient or Bidder.
6. Making efforts to assist interested DBEs in obtaining necessary equipment, supplies, materials, or related assistance or services.
7. Effectively using the services of available minority/women community organizations; minority/women contractors' groups; local, State, and Federal minority/women business assistance offices; and other organizations as allowed on a case-by-case basis to provide assistance in the recruitment and placement of DBEs.
8. GFE Documentation must include copies of each DBE and non-DBE subcontractor quotes submitted to the Bidder when a non-DBE subcontractor is selected over a DBE for Work on the Contract. (ref. updated DBE regulations – 26.53(b)(2)(vi) & App. A)

Administrative Reconsideration of GFE Documentation

A Bidder has the right to request reconsideration if the GFE Documentation submitted with their Bid was determined to be inadequate or without merit. If, during the life of the Contract, the Contractor submits an additional GFE Documentation and the Contracting Agency's GFE Documentation review determines a GFE Documentation is inadequate or has no merit, the Contractor has the right to request reconsideration of the Contracting Agency's determination.

1. The Bidder must request reconsideration within 48 hours of notification of GFE Documentation being inadequate or without merit, or the Bidder forfeits the right to reconsideration.
2. The reconsideration decision on the adequacy or merit of the Bidder's GFE Documentation shall be made by an official who did not take part in the original determination.

- 3 Only original GFE Documentation submitted as a supplement to the Bid will be considered. The Bidder shall not introduce new documentation at the reconsideration hearing.
- 4 The Bidder shall have the opportunity to meet in person with the official for the purpose of setting forth the Bidder's position as to why the GFE Documentation demonstrates a sufficient effort.
- 5 The reconsideration official shall provide the Bidder with a written decision on reconsideration within five working days of the hearing explaining the basis for their finding.

Consequences of Non-Compliance

Breach of Contract

Each contract with a Contractor (and each subcontract the Contractor signs with a subcontractor) must include the following assurance clause:

The Contractor, subrecipient, or subcontractor shall not discriminate on the basis of race, color, national origin, or sex in the performance of this contract. The Contractor shall carry out applicable requirements of 49 CFR Part 26 in the award and administration of DOT-assisted contracts. Failure by the Contractor to carry out these requirements is a material breach of this Contract, which may result in the termination of this Contract or such other remedy as the recipient deems appropriate, which may include, but is not limited to:

- (1) Withholding monthly progress payments;
- (2) Assessing sanctions;
- (3) Liquidated damages; and/or
- (4) Disqualifying the Contractor from future bidding as non-responsible.

If the Contractor or any subcontractor of any tier, supplier, service providers, or professional services is deemed to be in non-compliance, the Contractor will be informed in writing by the Engineer that sanctions will be imposed for failure to meet the DBE COA Commitment and/or submit documentation of good faith efforts. The notice will state the specific sanctions to be imposed which may include impacting a Contractor or other entity's ability to participate in future contracts.

Sanctions

If it is determined that the Contractor's failure to meet all or part of the DBE COA Commitment is due to the Contractor's inadequate good faith efforts throughout the life of the Contract, including failure to submit timely, required Good Faith Efforts information and documentation, the Contractor may be required to pay DBE penalty equal to the amount of the unmet Commitment, in addition to the sanctions outlined in Section 1-07.11(5).

Payment

Compensation for all costs involved with complying with the conditions of this Specification and any other associated DBE requirements is included in payment for the associated Contract items of Work, except otherwise provided in the Specifications.

1-07.11(2) Contractual Requirements*Supplement**(January 24, 2024 WSDOT GSP. Option 1)*

Section 1-07.11(2) is supplemented with the following:

11. The Contractor shall comply with the following nondiscrimination provisions, and the Contractor shall ensure the nondiscrimination provisions are included in all subcontracts:
 - a. Nondiscrimination Requirement. During the term of this Contract, the Contractor, including all subcontractors, shall not discriminate on the bases enumerated at RCW 49.60.530(3). In addition, the Contractor, including all subcontractors, shall give written notice of this nondiscrimination requirement to any labor organizations with which the Contractor, or subcontractor, has a collective bargaining or other agreement.
 - b. Obligation to Cooperate. The Contractor, including all subcontractors, shall cooperate and comply with any Washington state agency investigation regarding any allegation that the Contractor, including any subcontractor, has engaged in discrimination prohibited by this Contract pursuant to RCW 49.60.530(3).
 - c. Default. Notwithstanding any provision to the contrary, the Contracting Agency may suspend the Contract in accordance with Section 1-08.6, upon notice of a failure to participate and cooperate with any state agency investigation into alleged discrimination prohibited by this Contract, pursuant to RCW 49.60.530(3). Any such suspension will remain in place until the Contracting Agency receives notification that Contractor, including any subcontractor, is cooperating with the investigating state agency. In the event the Contractor, or subcontractor, is determined to have engaged in discrimination identified at RCW 49.60.530(3), the Contracting Agency may terminate this Contract in whole or in part in accordance with Section 1-08.10(1), and in addition to the sanctions listed in Section 1-07.11(5), the Contractor, subcontractor, or both, may be referred for debarment as provided in RCW 39.26.200. The Contractor or subcontractor may be given a reasonable time in which to cure this noncompliance, including implementing conditions consistent with any court-ordered injunctive relief or settlement agreement.
 - d. Remedies for Breach. Notwithstanding any provision to the contrary, in the event of Contract termination or suspension for engaging in discrimination, the Contractor, subcontractor, or both, shall be liable for contract damages as authorized by law including, but not limited to, any cost difference between the original contract and the replacement or cover contract and all administrative costs directly related to the replacement contract, which damages are distinct

from any penalties imposed under Chapter 49.60, RCW. The Contracting Agency shall have the right to deduct from any monies due to Contractor or subcontractor, or that thereafter become due, an amount for damages Contractor or subcontractor will owe Contracting Agency for default under this Provision.

1-07.12 Federal Agency Inspection

Supplement

(October 3, 2023 WSDOT GSP, Option 1)

Section 1-07.12 is supplemented with the following:

Required Federal Aid Provisions

The Required Contract Provisions Federal Aid Construction Contracts (FHWA 1273) Revised October 23, 2023 and the amendments thereto supersede any conflicting provisions of the Standard Specifications and are made a part of this Contract; provided, however, that if any of the provisions of FHWA 1273, as amended, are less restrictive than Washington State Law, then the Washington State Law shall prevail.

The provisions of FHWA 1273, as amended, included in this Contract require that the Contractor insert the FHWA 1273 and amendments thereto in each Subcontract, together with the wage rates which are part of the FHWA 1273, as amended. Also, a clause shall be included in each Subcontract requiring the Subcontractors to insert the FHWA 1273 and amendments thereto in any lower tier Subcontracts, together with the wage rates. The Contractor shall also ensure that this section, REQUIRED FEDERAL AID PROVISIONS, is inserted in each Subcontract for Subcontractors and lower tier Subcontractors. For this purpose, upon request to the Project Engineer, the Contractor will be provided with extra copies of the FHWA 1273, the amendments thereto, the applicable wage rates, and this Special Provision.

1-07.17 Utilities and Similar Facilities

Supplement

(October 3, 2022 WSDOT GSP, Option 2)

Section 1-07.17 is supplemented with the following:

Locations and dimensions shown in the Plans for existing facilities are in accordance with available information obtained without uncovering, measuring, or other verification.

Public and private utilities, or their Contractors, will furnish all work necessary to adjust, relocate, replace, or construct their facilities unless otherwise provided for in the Plans or these Special Provisions. Such adjustment, relocation, replacement, or construction will be done during the prosecution of the work for this project. It is anticipated that utility adjustment, relocation, replacement or construction within the project limits will be completed as follows:

Adjustment of existing utility castings to the new grade will be performed by the contractor and bid item(s) unless otherwise noted. Affected utility franchises may at their discretion provide new castings at time of final adjustment.

The Contractor shall attend a mandatory utility preconstruction meeting with the Engineer, all affected Subcontractors, and all utility owners and their Contractors prior to beginning onsite work.

The following addresses and telephone numbers of utility companies or their Contractors that will be adjusting, relocating, replacing or constructing utilities within the project limits are supplied for the Contractor's use:

Lakewood Water District
Attention: Bobby Gaskin
P.O. Box 99729
11900 Gravelly Lake Drive SW
Lakewood, Washington 98499
Telephone: 253.588.4423

Clover Park School District
Business Office
Attn: Bruce Gardner
10903 Gravelly Lake Drive SW
Lakewood, WA 98499
Telephone: 253.583.5011

City of Lakewood Police Department
9401 Lakewood Drive SW
Lakewood, WA 98499
Telephone: 253.588.4423

U.S. Post Office
Lakewood Center Branch
Attention: Tim Fox
Lakewood, WA 98499
Telephone: 800.275.8777

Pierce County Sewer
Attention: Jason Weekes
10311 Chambers Creek Road West
Tacoma, WA 98467-1040
Telephone: 253.798.3037
Jason.Weekes@piercecountywa.gov

Puget Sound Energy (Gas and Power)
Attention: David Brown
3130 S, 38th Street
Tacoma, WA 98409
Telephone: 360.475.7031
David.P.Brown@pse.com

West Pierce Fire
District # 2
7509 Grange West
Lakewood, Washington 98499
Telephone: 253.582.4600 (Station)

Pierce County Traffic
Attention: Rick Butner
4301 S Pine St., Suite 446
Tacoma, WA 98409
Telephone: 253.531.6990

Tacoma Power
Attention: Joe Rempe
3628 South 35th Street
Tacoma, Washington 98411-0007
Telephone: 253.502.8290

Lakeview Light & Power
Attention: John Devore
11509 Bridgeport Way SW
Lakewood, Washington 98499
Telephone: 253.584.6060

Comcast
Attention: Greg Giddens
410 Valley Avenue NW Ste 9
Puyallup, WA 98391
Telephone: 253.993.6087
Greg_Giddens2@comcast.com

Lumen Engineering Department
Attention: Rob Bair
2510 South 84th Street, Suite 18
Lakewood, WA 98499
Telephone: 253.733.8871

Pierce Transit
Attention: Mark Davilla
3701 96th Street SW
P.O. Box 99070
Lakewood, Washington 98499-0070
Telephone: 253.405.1163

City of Lakewood Operations and
Maintenance
Attention: Scott Williams
9420 Front St S.
Lakewood, WA 98499
Telephone: 253.377.4392

Underground Utilities Location Center
("One-Call Center")
800.424.5555

1-07.18 Public Liability and Property Damage Insurance

Replacement

Delete this section in its entirety, and replace it with the following:

1-07.18 Insurance

(January 4, 2024 APWA GSP)

1-07.18(1) General Requirements

- A. The Contractor shall procure and maintain the insurance described in all subsections of section 1-07.18 of these Special Provisions, from insurers with a current A. M. Best rating of not less than A-: VII and licensed to do business in the State of Washington. The Contracting Agency reserves the right to approve or reject the insurance provided, based on the insurer's financial condition.
- B. The Contractor shall keep this insurance in force without interruption from the commencement of the Contractor's Work through the term of the Contract and for thirty (30) days after the Physical Completion date, unless otherwise indicated below.
- C. If any insurance policy is written on a claims-made form, its retroactive date, and that of all subsequent renewals, shall be no later than the effective date of this Contract. The policy shall state that coverage is claims made and state the retroactive date. Claims-made form coverage shall be maintained by the Contractor for a minimum of 36 months following the Completion Date or earlier termination of this Contract, and the Contractor shall annually provide the Contracting Agency with proof of renewal. If renewal of the claims made form of coverage becomes unavailable, or economically prohibitive, the Contractor shall purchase an extended reporting period ("tail") or execute another form of guarantee acceptable to the Contracting Agency to assure financial responsibility for liability for services performed.
- D. The Contractor's Automobile Liability, Commercial General Liability and Excess or Umbrella Liability insurance policies shall be primary and non-contributory insurance as respects the Contracting Agency's insurance, self-insurance, or self-insured pool coverage. Any insurance, self-insurance, or self-insured pool coverage maintained by the Contracting Agency shall be excess of the Contractor's insurance and shall not contribute with it.

- E. The Contractor shall provide the Contracting Agency and all additional insureds with written notice of any policy cancellation, within two business days of their receipt of such notice.
- F. The Contractor shall not begin work under the Contract until the required insurance has been obtained and approved by the Contracting Agency
- G. Failure on the part of the Contractor to maintain the insurance as required shall constitute a material breach of contract, upon which the Contracting Agency may, after giving five business days' notice to the Contractor to correct the breach, immediately terminate the Contract or, at its discretion, procure or renew such insurance and pay any and all premiums in connection therewith, with any sums so expended to be repaid to the Contracting Agency on demand, or at the sole discretion of the Contracting Agency, offset against funds due the Contractor from the Contracting Agency.
- H. All costs for insurance shall be incidental to and included in the unit or lump sum prices of the Contract and no additional payment will be made.
- I. Under no circumstances shall a wrap up policy be obtained, for either initiating or maintaining coverage, to satisfy insurance requirements for any policy required under this Section. A "wrap up policy" is defined as an insurance agreement or arrangement under which all the parties working on a specified or designated project are insured under one policy for liability arising out of that specified or designated project.

1-07.18(2) Additional Insured

All insurance policies, with the exception of Workers Compensation, and of Professional Liability and Builder's Risk (if required by this Contract) shall name the following listed entities as additional insured(s) using the forms or endorsements required herein:

- the Contracting Agency and its officers, elected officials, employees, agents, and volunteers

The above-listed entities shall be additional insured(s) for the full available limits of liability maintained by the Contractor, irrespective of whether such limits maintained by the Contractor are greater than those required by this Contract, and irrespective of whether the Certificate of Insurance provided by the Contractor pursuant to 1-07.18(4) describes limits lower than those maintained by the Contractor.

For Commercial General Liability insurance coverage, the required additional insured endorsements shall be at least as broad as ISO forms CG 20 10 10 01 for ongoing operations and CG 20 37 10 01 for completed operations.

1-07.18(3) Subcontractors

The Contractor shall cause each subcontractor of every tier to provide insurance coverage that complies with all applicable requirements of the Contractor-provided insurance as set forth herein, except the Contractor shall have sole responsibility for determining the limits of coverage required to be obtained by subcontractors.

The Contractor shall ensure that all subcontractors of every tier add all entities listed in 1-07.18(2) as additional insureds, and provide proof of such on the policies as required by that section as detailed in 1-07.18(2) using an endorsement as least as broad as ISO CG 20 10 10 01 for ongoing operations and CG 20 37 10 01 for completed operations.

Upon request by the Contracting Agency, the Contractor shall forward to the Contracting Agency evidence of insurance and copies of the additional insured endorsements of each subcontractor of every tier as required in 1-07.18(4) Verification of Coverage.

1-07.18(4) Verification of Coverage

The Contractor shall deliver to the Contracting Agency a Certificate(s) of Insurance and endorsements for each policy of insurance meeting the requirements set forth herein when the Contractor delivers the signed Contract for the work. Failure of Contracting Agency to demand such verification of coverage with these insurance requirements or failure of Contracting Agency to identify a deficiency from the insurance documentation provided shall not be construed as a waiver of Contractor's obligation to maintain such insurance.

Verification of coverage shall include:

1. An ACORD certificate or a form determined by the Contracting Agency to be equivalent.
2. Copies of all endorsements naming Contracting Agency and all other entities listed in 1-07.18(2) as additional insured(s), showing the policy number. The Contractor may submit a copy of any blanket additional insured clause from its policies instead of a separate endorsement.
3. Any other amendatory endorsements to show the coverage required herein.
4. A notation of coverage enhancements on the Certificate of Insurance shall not satisfy these requirements – actual endorsements must be submitted.

Upon request by the Contracting Agency, the Contractor shall forward to the Contracting Agency a full and certified copy of the insurance policy(s). If Builders Risk insurance is required on this Project, a full and certified copy of that policy is required when the Contractor delivers the signed Contract for the work.

1-07.18(5) Coverages and Limits

The insurance shall provide the minimum coverages and limits set forth below. Contractor's maintenance of insurance, its scope of coverage, and limits as required herein shall not be construed to limit the liability of the Contractor to the coverage provided by such insurance, or otherwise limit the Contracting Agency's recourse to any remedy available at law or in equity.

All deductibles and self-insured retentions must be disclosed and are subject to approval by the Contracting Agency. The cost of any claim payments falling within the deductible or self-insured retention shall be the responsibility of the Contractor. In the event an additional insured incurs a liability subject to any policy's deductibles or self-insured

retention, said deductibles or self-insured retention shall be the responsibility of the Contractor.

1-07.18(5)A Commercial General Liability

Commercial General Liability insurance shall be written on coverage forms at least as broad as ISO occurrence form CG 00 01, including but not limited to liability arising from premises, operations, stop gap liability, independent contractors, products-completed operations, personal and advertising injury, and liability assumed under an insured contract. There shall be no exclusion for liability arising from explosion, collapse or underground property damage.

The Commercial General Liability insurance shall be endorsed to provide a per project general aggregate limit, using ISO form CG 25 03 05 09 or an equivalent endorsement.

Contractor shall maintain Commercial General Liability Insurance arising out of the Contractor’s completed operations for at least three years following Substantial Completion of the Work.

Such policy must provide the following minimum limits:

\$2,000,000	Each Occurrence
\$3,000,000	General Aggregate
\$3,000,000	Products & Completed Operations Aggregate
\$2,000,000	Personal & Advertising Injury each offence
\$2,000,000	Stop Gap / Employers’ Liability each accident

1-07.18(5)B Automobile Liability

Automobile Liability shall cover owned, non-owned, hired, and leased vehicles; and shall be written on a coverage form at least as broad as ISO form CA 00 01. If the work involves the transport of pollutants, the automobile liability policy shall include MCS 90 and CA 99 48 endorsements.

Such policy must provide the following minimum limit:

\$1,000,000	Combined single limit each accident
-------------	-------------------------------------

1-07.18(5)C Workers’ Compensation

The Contractor shall comply with Workers’ Compensation coverage as required by the Industrial Insurance laws of the State of Washington.

1-07.23(1) Construction Under Traffic

Supplement

(May 2, 2017 APWA GSP)

Revise the third sentence of the second paragraph to read:

Accessibility to existing or temporary pedestrian push buttons shall not be impaired; if approved by the Contracting Agency activating pedestrian recall timing or other accommodation may be allowed during construction.

(*****)

Section 1-07.23(1) is supplemented with the following:

Lane closures are subject to the following restrictions:

All travel lanes shall be opened to traffic at the end of each work shift unless it is deemed unsafe to do so by the Engineer.

If the Engineer determines the permitted closure hours adversely affect traffic, the Engineer may adjust the hours accordingly. The Engineer will notify the Contractor in writing of any change in the closure hours.

Lane closures are not allowed on any of the following:

1. A holiday,
2. A holiday weekend; holidays that occur on Friday, Saturday, Sunday or Monday are considered a holiday weekend. A holiday weekend includes Saturday, Sunday, and the holiday.
3. On the day prior to a holiday or holiday weekend

1-07.24 Rights of Way

Replacement

(July 23, 2015 APWA GSP)

Delete this section and replace it with the following:

Street Right of Way lines, limits of easements, and limits of construction permits are indicated in the Plans. The Contractor's construction activities shall be confined within these limits, unless arrangements for use of private property are made.

Generally, the Contracting Agency will have obtained, prior to bid opening, all rights of way and easements, both permanent and temporary, necessary for carrying out the work. Exceptions to this are noted in the Bid Documents or will be brought to the Contractor's attention by a duly issued Addendum.

Whenever any of the work is accomplished on or through property other than public Right of Way, the Contractor shall meet and fulfill all covenants and stipulations of any easement agreement obtained by the Contracting Agency from the owner of the private property. Copies of the easement agreements may be included in the Contract Provisions or made available to the Contractor as soon as practical after they have been obtained by the Engineer.

Whenever easements or rights of entry have not been acquired prior to advertising, these areas are so noted in the Plans. The Contractor shall not proceed with any portion of the work in areas where right of way, easements or rights of entry have not been acquired until the Engineer certifies to the Contractor that the right of way or easement is available or that the right of entry has been

received. If the Contractor is delayed due to acts of omission on the part of the Contracting Agency in obtaining easements, rights of entry or right of way, the Contractor will be entitled to an extension of time. The Contractor agrees that such delay shall not be a breach of contract.

Each property owner shall be given 48 hours notice prior to entry by the Contractor. This includes entry onto easements and private property where private improvements must be adjusted.

The Contractor shall be responsible for providing, without expense or liability to the Contracting Agency, any additional land and access thereto that the Contractor may desire for temporary construction facilities, storage of materials, or other Contractor needs. However, before using any private property, whether adjoining the work or not, the Contractor shall file with the Engineer a written permission of the private property owner, and, upon vacating the premises, a written release from the property owner of each property disturbed or otherwise interfered with by reasons of construction pursued under this contract. The statement shall be signed by the private property owner, or proper authority acting for the owner of the private property affected, stating that permission has been granted to use the property and all necessary permits have been obtained or, in the case of a release, that the restoration of the property has been satisfactorily accomplished. The statement shall include the parcel number, address, and date of signature. Written releases must be filed with the Engineer before the Completion Date will be established.

1-08 PROSECUTION AND PROGRESS

Add the following new section:

1-08.0 Preliminary Matters

New

(May 25, 2006 APWA GSP)

1-08.0(1) Preconstruction Conference

(July 8, 2008 APWA GSP)

Prior to the Contractor beginning the work, a preconstruction conference will be held between the Contractor, the Engineer and such other interested parties as may be invited. The purpose of the preconstruction conference will be:

1. To review the initial progress schedule;
2. To establish a working understanding among the various parties associated or affected by the work;
3. To establish and review procedures for progress payment, notifications, approvals, submittals, etc.;
4. To review DBE Requirements, Training Plans, and Apprenticeship Plans, when applicable

5. To establish normal working hours for the work;
6. To review safety standards and traffic control; and
7. To discuss such other related items as may be pertinent to the work.

The Contractor shall prepare and submit at the preconstruction conference the following:

1. A breakdown of all lump sum items;
2. A preliminary schedule of working drawing submittals; and
3. A list of material sources for approval if applicable.

1-08.0(2) Hours of Work

New

(December 8, 2014 APWA GSP)

Except in the case of emergency or unless otherwise approved by the Engineer, the normal working hours for the Contract shall be any consecutive 8-hour period between 7:00 a.m. and 6:00 p.m. Monday through Friday, exclusive of a lunch break. If the Contractor desires different than the normal working hours stated above, the request must be submitted in writing prior to the preconstruction conference, subject to the provisions below. The working hours for the Contract shall be established at or prior to the preconstruction conference.

All working hours and days are also subject to local permit and ordinance conditions (such as noise ordinances).

If the Contractor wishes to deviate from the established working hours, the Contractor shall submit a written request to the Engineer for consideration. This request shall state what hours are being requested, and why. Requests shall be submitted for review no later than 5 working days prior to the day(s) the Contractor is requesting to change the hours.

If the Contracting Agency approves such a deviation, such approval may be subject to certain other conditions, which will be detailed in writing. For example:

1. On non-Federal aid projects, requiring the Contractor to reimburse the Contracting Agency for the costs in excess of straight-time costs for Contracting Agency representatives who worked during such times. (The Engineer may require designated representatives to be present during the work. Representatives who may be deemed necessary by the Engineer include, but are not limited to: survey crews; personnel from the Contracting Agency's material testing lab; inspectors; and other Contracting Agency employees or third party consultants when, in the opinion of the Engineer, such work necessitates their presence.)
2. Considering the work performed on Saturdays, Sundays, and holidays as working days with regard to the contract time.
3. Considering multiple work shifts as multiple working days with respect to contract time even though the multiple shifts occur in a single 24-hour period.
4. If a 4-10 work schedule is requested and approved the non working day for the week will be charged as a working day.

5. If Davis Bacon wage rates apply to this Contract, all requirements must be met and recorded properly on certified payroll

1-08.1 Subcontracting*Supplement**(December 30, 2022 APWA GSP, Option A)*

Section 1-08.1 is supplemented with the following

Prior to any subcontractor or lower tier subcontractor beginning work, the Contractor shall submit to the Engineer a certification (WSDOT Form 420-004) that a written agreement between the Contractor and the subcontractor or between the subcontractor and any lower tier subcontractor has been executed. This certification shall also guarantee that these subcontract agreements include all the documents required by the Special Provision Federal Agency Inspection.

A subcontractor or lower tier subcontractor will not be permitted to perform any work under the contract until the following documents have been completed and submitted to the Engineer:

1. Request to Sublet Work (WSDOT Form 421-012), and
2. Contractor and Subcontractor or Lower Tier Subcontractor Certification for Federal-aid Projects (WSDOT Form 420-004).

The Contractor shall submit to the Engineer a completed Monthly Retainage Report (WSDOT Form 272-065) within 15 calendar days after receipt of every monthly progress payment until every subcontractor and lower tier subcontractor's retainage has been released.

The Contractor's records pertaining to the requirements of this Special Provision shall be open to inspection or audit by representatives of the Contracting Agency during the life of the contract and for a period of not less than three years after the date of acceptance of the contract. The Contractor shall retain these records for that period. The Contractor shall also guarantee that these records of all subcontractors and lower tier subcontractors shall be available and open to similar inspection or audit for the same time period.

1-08.1(7) Payments to Subcontractors and Lower-Tier Subcontractors*Revision***1-08.1(7)A Payment Reporting**

The first paragraph of section 1-08.1(7)A is revised to read:

(July 2, 2024, WSDOT GSP)

The Contractor shall report the actual amounts paid to all firms that were used as subcontractors of any tier, materials suppliers, manufacturers, regular dealers, or service providers on the Contract, including all Disadvantaged, Minority, Small, Veteran, or Women's Business Enterprise firms. The following do not need reported: (1) retail sales

or services that are paid for at the time of purchase; (2) payments to materials suppliers or manufacturers that are in normal course of business. The Contractor shall report this information by entering it into the Contracting Agency's Diversity Management and compliance System at: <https://wsdot.diversitycompliance.com>. Payments shall be reported no later than the 20th of the month for all payments made to firms during the previous calendar month. For example, the Contractor shall enter all payments made to firms during the month of March into DMCS by April 20th. Payments shall be reported between execution of the Contract and the contract Completion Date. When no Work occurred or no payments were made at a firm, the reported payment shall be zero.

1-08.1(7)C Subcontractor Retainage

The first sentence in the last paragraph of Section 1-08.1(7)C is revised to read:

(February 13, 2024, WSDOT GSP)

If the Contractor fails to comply with the requirements of this Section and the first-tier subcontractor's retainage or retainage bond is wrongfully withheld, the Contractor will be subject to the actions described in Section 1-08.1(10).

1-08.1(9) Submittal of Executed DBE Subcontracts

Supplement

(September 3, 2024 APWA GSP, Option A)

Section 1-08.1(9) is supplemented with the following:

Submittal of Executed DBE Subcontracts

Prior to a DBE performing Work on the Contract, an executed subcontract between the DBE and the Contractor shall be submitted to the Engineer. The executed subcontracts shall be submitted by email to the following email address for the region administering the Contract:

adobrovidova@cityoflakewood.us; ORegionOEO@wsdot.wa.gov

1-08.3(2)A Type A Progress Schedule

Revision

(December 30, 2022 APWA GSP)

Revise this section to read:

The Contractor shall submit 3 copies of a Type A Progress Schedule no later than at the preconstruction conference, or some other mutually agreed upon submittal time. The schedule may be a critical path method (CPM) schedule, bar chart, or other standard schedule format. Regardless of which format used, the schedule shall identify the critical path. The Engineer will evaluate the Type A Progress Schedule and approve or return the schedule for corrections within 15 calendar days of receiving the submittal.

1-08.4 Prosecution of Work*Replacement*

Delete this section and replace it with the following:

1-08.4 Notice to Proceed and Prosecution of Work*(July 23, 2015 APWA GSP)*

Notice to Proceed will be given after the contract has been executed and the contract bond and evidence of insurance have been approved and filed by the Contracting Agency. The Contractor shall not commence with the work until the Notice to Proceed has been given by the Engineer. The Contractor shall commence construction activities on the project site within ten days of the Notice to Proceed Date, unless otherwise approved in writing. The Contractor shall diligently pursue the work to the physical completion date within the time specified in the contract. Voluntary shutdown or slowing of operations by the Contractor shall not relieve the Contractor of the responsibility to complete the work within the time(s) specified in the contract.

When shown in the Plans, the first order of work shall be the installation of high visibility fencing to delineate all areas for protection or restoration, as described in the Contract. Installation of high visibility fencing adjacent to the roadway shall occur after the placement of all necessary signs and traffic control devices in accordance with 1-10.1(2). Upon construction of the fencing, the Contractor shall request the Engineer to inspect the fence. No other work shall be performed on the site until the Contracting Agency has accepted the installation of high visibility fencing, as described in the Contract.

The cost of preparing the progress schedule, any supplementary progress schedules, and weekly schedules shall be considered incidental to the Contract and no other compensation shall be made.

1-08.5 Time for Completion*Supplement**(March 13, 1995 WSDOT GSP, Option 7)*

Section 1-08.5 is supplemented with the following:

This project shall be physically completed within **15** working days.

(December 30, 2022 APWA GSP, Option A)

Revise the third and fourth paragraphs to read:

Contract time shall begin on the first working day following the Notice to Proceed Date.

Each working day shall be charged to the contract as it occurs, until the contract work is physically complete. If substantial completion has been granted and all the authorized working days have been used, charging of working days will cease. Each week the Engineer will provide the Contractor a statement that shows the number of working days: (1) charged to the contract the week before; (2) specified for the physical completion of the contract; and (3) remaining for the physical completion of the contract. The statement will also show the nonworking days and all partial or whole days the Engineer declares as unworkable. The statement will be identified as a Written Determination by the Engineer.

If the Contractor does not agree with the Written Determination of working days, the Contractor shall pursue the protest procedures in accordance with Section 1-04.5. By failing to follow the procedures of Section 1-04.5, the Contractor shall be deemed as having accepted the statement as correct. If the Contractor is approved to work 10 hours a day and 4 days a week (a 4-10 schedule) and the fifth day of the week in which a 4-10 shift is worked would ordinarily be charged as a working day then the fifth day of that week will be charged as a working day whether or not the Contractor works on that day.

Revise the sixth paragraph to read:

The Engineer will give the Contractor written notice of the completion date of the contract after all the Contractor's obligations under the contract have been performed by the Contractor. The following events must occur before the Completion Date can be established:

1. The physical work on the project must be complete; and
2. The Contractor must furnish all documentation required by the contract and required by law, to allow the Contracting Agency to process final acceptance of the contract. The following documents must be received by the Project Engineer prior to establishing a completion date:
 - a. Certified Payrolls (per Section 1-07.9(5)).
 - b. Material Acceptance Certification Documents
 - c. Monthly Reports of Amounts Credited as DBE Participation, as required by the Contract Provisions.
 - d. Final Contract Voucher Certification
 - e. Copies of the approved "Affidavit of Prevailing Wages Paid" for the Contractor and all Subcontractors
 - f. A copy of the Notice of Termination sent to the Washington State Department of Ecology (Ecology); the elapse of 30 calendar days from the date of receipt of the Notice of Termination by Ecology; and no rejection of the Notice of Termination by Ecology. This requirement will not apply if the Construction Stormwater General Permit is transferred back to the Contracting Agency in accordance with Section 8-01.3(16).
 - g. Property owner releases per Section 1-07.24

1-08.9 Liquidated Damages

Replacement

(March 3, 2021 APWA GSP, Option A)

Replace Section 1-08.9 with the following:

Time is of the essence of the Contract. Delays inconvenience the traveling public, obstruct traffic, interfere with and delay commerce, and increase risk to Highway users. Delays also cost tax payers undue sums of money, adding time needed for administration, engineering, inspection, and supervision.

Accordingly, the Contractor agrees:

1. To pay liquidated damages in the amount of \$1,450.00 for each working day beyond the number of working days established for Physical Completion, and

2. To authorize the Engineer to deduct these liquidated damages from any money due or coming due to the Contractor.

When the Contract Work has progressed to Substantial Completion as defined in the Contract, the Engineer may determine the Contract Work is Substantially Complete. The Engineer will notify the Contractor in writing of the Substantial Completion Date. For overruns in Contract time occurring after the date so established, liquidated damages identified above will not apply. For overruns in Contract time occurring after the Substantial Completion Date, liquidated damages shall be assessed on the basis of direct engineering and related costs assignable to the project until the actual Physical Completion Date of all the Contract Work. The Contractor shall complete the remaining Work as promptly as possible. Upon request by the Project Engineer, the Contractor shall furnish a written schedule for completing the physical Work on the Contract.

Liquidated damages will not be assessed for any days for which an extension of time is granted. No deduction or payment of liquidated damages will, in any degree, release the Contractor from further obligations and liabilities to complete the entire Contract.

1-09 MEASUREMENT AND PAYMENT

1-09.2(1) General Requirements for Weighing Equipment

Modification

(January 4, 2024 APWA GSP, Option B)

Revise item 4 of the fifth paragraph to read:

4. Test results and scale weight records for each day's hauling operations are provided to the Engineer daily. Reporting shall utilize WSDOT form 422-027A, Scaleman's Daily Report, unless the printed ticket contains the same information that is on the Scaleman's Daily Report Form. The scale operator must provide AM and/or PM tare weights for each truck on the printed ticket.

1-09.2(5) Measurement

Modification

(December 30, 2022 APWA GSP)

Revise the first paragraph to read:

Scale Verification Checks – At the Engineer's discretion, the Engineer may perform verification checks on the accuracy of each batch, hopper, or platform scale used in weighing contract items of Work.

1-09.6 Force Account

Supplement

(December 30, 2022 APWA GSP)

Supplement this section with the following:

The Contracting Agency has estimated and included in the Proposal, dollar amounts for all items to be paid per force account, only to provide a common proposal for Bidders. All such dollar amounts are to become a part of Contractor's total bid. However, the Contracting Agency does not warrant expressly or by implication, that the actual amount of work will correspond with those estimates. Payment will be made on the basis of the amount of work actually authorized by the Engineer.

1-09.9 Payments*Modification**(July 8, 2024 APWA GS, Option A)*

Supplement this section with the following:

Lump sum item breakdowns are not required when the bid price for the lump sum item is less than \$20,000.

(July 8, 2024 APWA GSP Option B)

Delete the fourth paragraph and replace it with the following:

Progress payments for completed work and material on hand will be based upon progress estimates prepared by the Engineer. A progress estimate cutoff date will be established at the preconstruction conference.

The initial progress estimate will be made not later than 30 days after the Contractor commences the work, and successive progress estimates will be made every month thereafter until the Completion Date. Progress estimates made during progress of the work are tentative, and made only for the purpose of determining progress payments. The progress estimates are subject to change at any time prior to the calculation of the final payment.

The value of the progress estimate will be the sum of the following:

1. Unit Price Items in the Bid Form — the approximate quantity of acceptable units of work completed multiplied by the unit price.
2. Lump Sum Items in the Bid Form — based on the approved Contractor's lump sum breakdown for that item, or absent such a breakdown, based on the Engineer's determination.
3. Materials on Hand — 100 percent of invoiced cost of material delivered to Job site or other storage area approved by the Engineer.
4. Change Orders — entitlement for approved extra cost or completed extra work as determined by the Engineer.

Progress payments will be made in accordance with the progress estimate less:

1. Retainage per Section 1-09.9(1), on non FHWA-funded projects;
2. The amount of progress payments previously made; and
3. Funds withheld by the Contracting Agency for disbursement in accordance with the Contract Documents.

Progress payments for work performed shall not be evidence of acceptable performance or an admission by the Contracting Agency that any work has been satisfactorily completed. The determination of payments under the contract will be final in accordance with Section 1-05.1.

1-09.9(1) Retainage*Replacement*

Section 1-09.9(1) content and title is deleted and replaced with the following:

(June 27, 2011 WSDOT GSP, Option 1)

Vacant

1-09.11(3) Time Limitation and Jurisdiction*Modification*

(December 30, 2022 APWA GSP)

Revise this section to read:

For the convenience of the parties to the Contract it is mutually agreed by the parties that all claims or causes of action which the Contractor has against the Contracting Agency arising from the Contract shall be brought within 180 calendar days from the date of final acceptance (Section 1-05.12) of the Contract by the Contracting Agency; and it is further agreed that all such claims or causes of action shall be brought only in the Superior Court of the county where the Contracting Agency headquarters is located, provided that where an action is asserted against a county, RCW 36.01.050 shall control venue and jurisdiction. The parties understand and agree that the Contractor's failure to bring suit within the time period provided, shall be a complete bar to all such claims or causes of action. It is further mutually agreed by the parties that when claims or causes of action which the Contractor asserts against the Contracting Agency arising from the Contract are filed with the Contracting Agency or initiated in court, the Contractor shall permit the Contracting Agency to have timely access to all records deemed necessary by the Contracting Agency to assist in evaluating the claims or action.

1-09.13(3)A Arbitration General*Modification*

(January 19, 2022 APWA GSP)

Revise the third paragraph to read:

The Contracting Agency and the Contractor mutually agree to be bound by the decision of the arbitrator, and judgment upon the award rendered by the arbitrator may be entered in the Superior Court of the county in which the Contracting Agency's headquarters is located, provided that where claims subject to arbitration are asserted against a county, RCW 36.01.050 shall control venue and jurisdiction of the Superior Court. The decision of the arbitrator and the specific basis for the decision shall be in writing. The arbitrator shall use the Contract as a basis for decisions.

1-09.13(4) Venue for Litigation*Modification**(December 30, 2022 APWA GSP)*

Revise this section to read:

Litigation shall be brought in the Superior Court of the county in which the Contracting Agency's headquarters is located, provided that where claims are asserted against a county, RCW 36.01.050 shall control venue and jurisdiction of the Superior Court. It is mutually agreed by the parties that when litigation occurs, the Contractor shall permit the Contracting Agency to have timely access to all records deemed necessary by the Contracting Agency to assist in evaluating the claims or action.

1-10 TEMPORARY TRAFFIC CONTROL**1-10.2 Traffic Control Management***Supplement*

Section 1-10.2 is supplemented with the following:

*(November 2, 2022 WSDOT GSP, Option 1)****Work Zone Safety Contingency***

Enhancements to improve the effectiveness of the accepted traffic control plans to increase the safety of the work zones shall be discussed on a weekly basis between the Contractor and the Contracting Agency. Enhancements shall be mutually agreed upon by the Contractor and Engineer prior to performing any Work to implement the enhancement.

Enhancements do not include the use of Uniformed Police Officers or WSP, address changes to the allowed work hour restrictions, or changes to the staging plans in the Contract (if applicable). If allowed by the Engineer, these items will be addressed in accordance with Section 1-04.4.

The Contractor shall be solely responsible for submitting any traffic control plan revision to implement the enhancement in accordance with Section 1-10.2(2)

1-10.2(1) General*Supplement*

Section 1-10.2(1) is supplemented with the following:

(October 3, 2022 WSDOT GSP, Option 1)

The Traffic Control Supervisor shall be certified by one of the following:

The Northwest Laborers-Employers Training Trust
27055 Ohio Ave.
Kingston, WA 98346
(360) 297-3035
<https://www.nwlett.edu>

Evergreen Safety Council
12545 135th Ave. NE
Kirkland, WA 98034-8709
1-800-521-0778
<https://www.esc.org>

The American Traffic Safety Services Association
15 Riverside Parkway, Suite 100
Fredericksburg, Virginia 22406-1022
Training Dept. Toll Free (877) 642-4637
Phone: (540) 368-1701
<https://altssa.com/training>

Integrity Safety
13912 NE 20th Ave.
Vancouver, WA 98686
(360) 574-6071
<https://www.integritysafety.com>

US Safety Alliance
(904) 705-5660
<https://www.ussafetyalliance.com>

K&D Services Inc.
2719 Rockefeller Ave.
Everett, WA 98201
(800) 343-4049
<https://www.kndservices.net>

1-10.4 Measurement

1-10.4(2) Item Bids with Lump Sum for Incidentals

Supplement

Section 1-10.4(2) is supplemented with the following:

(August 2, 2004 WSDOT GSP, Option 1)

The bid proposal does not contain the item “Project Temporary Traffic Control,” lump sum. The provisions of Section 1-10.4(2) shall apply.

1-10.5 Payment

1-10.5(2) Item Bids with lump Sum for Incidentals

Supplement

Section 1-10.5(2) is supplemented with the following:

(November 2, 2022 WSDOT GSP, Option 7)

“Work Zone Safety Contingency”, by force account.

All costs as authorized by the Engineer will be paid for by force account as specified in Section 1-09.6.

For purpose of providing a common proposal for all bidders, the Contracting Agency has entered an amount for the item “Work Zone Safety Contingency” in the Proposal to become a part of the Contractor’s total bid.

The Engineer may choose to use existing bid items for the implementation of the agreed upon enhancement.

END OF DIVISION 1

DIVISION 2 EARTHWORK

2-01 CLEARING AND GRUBBING

2-01.1 Description *Supplement*

Section 2-01.1 is supplemented with the following:

Where, in the opinion of the Engineer, any trees abutting or adjacent to the areas of clearing and grubbing are damaged and require removal, the Contractor shall remove such trees. Any trees flagged by the Engineer to remain within the clearing and grubbing limits shall be left undamaged by the Contractor’s operations. Any marked trees damaged shall be replaced in kind, at the Contractor’s expense. For trees and shrubs which cannot be replaced in kind, the Contractor will be assessed damages equal to the triple value of the tree or shrub in accordance with Section 1-07.16(2) of the Standard Specifications.

Existing landscaping outside the construction limits, including but not limited to, sod, rockeries, irrigation systems, beauty bark, decorative gravel or rock, bushes, trees and shrubbery shall be protected from damage.

Clearing and Grubbing shall also include removal and disposal of trees and stumps, organic debris and stump grinding to a minimum of 2 feet below finished grade, as needed.

2-01.2 Disposal of Usable Material and Debris *Supplement*

Section 2-01.2 is supplemented with the following:

The Contractor shall use Disposal Method No. 2 – Waste Site. Disposal Method No. 1 – Open Burning or Disposal Method No. 3 – Chipping will not be permitted under this contract.

2-01.5 Disposal of Usable Material and Debris *Supplement*

Section 2-01.5 is supplemented with the following:

Payment will be made for the following bid item:

Clearing and Grubbing	Lump Sum
-----------------------	----------

The lump sum contract price for “Clearing and Grubbing” shall be full compensation for all work described herein and shown in the Plans, including removing trees, stumps, and shrubbery.

2-02 REMOVAL OF STRUCTURES AND OBSTRUCTIONS

2-02.1 Description

Supplement

Section 2-02.1 is supplemented with the following:

This work shall consist of the removal and disposal of various existing improvements, including but not limited to, pavement markings, drainage structures, foundations, junction boxes, fences, signs, mailbox supports/posts, and other items necessary for the accomplishment of the improvement.

This work also includes removal of pavement, curb and sidewalk, as directed by the Engineer, that falls outside of the roadway excavation limits.

It is to be understood that other aboveground or underground facilities not shown in the Plans may be encountered during the course of the work.

All utility valves, manholes, vaults, or pull boxes which are buried shall be conspicuously marked in a fashion acceptable to the Owner and Engineer by the Contractor to allow their location to be determined by the Engineer or utility personnel under adverse conditions (inclement weather or darkness).

Contractor shall check with the utility companies concerning any possible conflict prior to commencing excavation in any area. Contractor shall resolve all crossing and clearance problems with the utility company concerned. No excavation shall begin until all known facilities, in the vicinity of the excavation area, have been located and marked.

In addition to Contractor having all utilities field marked before starting work, Contractor shall have all utilities field marked after they are relocated in conjunction with this project.

At least 2 and not more than 10 business days prior to commencing any excavations for utility potholing or for any other purpose under this Contract, Contractor shall notify the Underground Utilities Location Center by telephone of the planned excavation and progress schedule. A business day is defined as any day other than Saturday, Sunday, or a legal local, state, or Federal holiday. Contractor is also warned that there may be utilities on the project that are not part of the One Call system. They must be contacted directly by Contractor for locations.

Contractor shall make arrangements 48 hours in advance with respective utility owners to have a representative present when their utility is exposed or modified, if the utility chooses to do so.

Existing utilities for telephone, power, gas, water, and television cable facilities shall be adjusted or relocated by the appropriate utility company unless otherwise noted in the Plans. These adjustments may be completed before Contractor begins work, or may be performed in conjunction with the contract work. Contractor shall be entirely responsible for coordination with the utility companies and arranging for the movement or adjustment, either temporary or permanent, of their facilities within the project limits. See also Section 1-05.14 of the WSDOT Standard Specifications.

If or when utility conflicts occur, Contractor shall continue the construction process on other aspects of the project whenever possible. No additional compensation will be made to Contractor for reason of delay caused by the actions of any utility company and Contractor shall consider such costs to be incidental to the other items of the contract.

In no way shall the work described under Utility Potholing relieve Contractor of any of the responsibilities described in Section 1-07.17 of the Standard Specifications and Special Provisions, and elsewhere in the Contract Documents.

Resolution of Utility Conflicts

The Contractor shall immediately notify the Engineer upon discovery of any unknown utility conflict. The Contractor shall not perform any further work in the 'unknown utility conflict area' until the Engineer has made a determination in the field of the nature of the work required and a written Field Change Authorization is issued.

2-02.3 Construction Requirements

Supplement

Section 2-02.3 is added as follows:

Unless noted in these Special Provisions or shown in the Plans, no removed material may be placed in any embankment or fill within the project site.

2-02.3(3) Removal of Pavement, Sidewalks, and Curbs

Supplement

Section 2-02.3(3) is supplemented with the following:

5. Neither impact tools nor pavement breakers may be used for trench crossings of existing pavement. Trench crossings of existing pavement shall be vertically sawcut.
6. Where gutter is to be placed integral with asphalt pavement as shown in the Plans, the Contractor shall take extra precaution to make a neat, uniform cut, and shall sawcut pavement to full depth, regardless of number of passes necessary. If, in the opinion of the engineer, the cut is not satisfactory due to Contractor's workmanship or equipment, the Contractor shall fix the problem to the satisfaction of the engineer, at Contractor's own expense.
7. The Contractor shall remove existing pavement, sidewalks, curb, curb and gutter, curb ramps or driveways as shown in the Plans. Additional removal of existing pavement beyond what is shown in the plans must be approved by the Engineer if necessary for the accomplishment of the improvements.

2-02.3(4) Cutting Pavement, Sidewalks, and Curbs

New

Section 2-02.3(4) is added as follows:

All transitions to existing asphalt or cement concrete driveways, parking lots, curb and gutter, and walkways shall be vertically sawcut full-depth with straight, uniform edges. Existing asphalt pavement roadway edge may be cut with a wheel, provided the wheel cut is full depth and no damage occurs to the pavement which is to remain. Neither impact tools nor pavement breakers may be used for trench crossing of existing pavement. Trench crossing of existing pavement shall be vertically sawcut.

Where gutter is to be placed integral with asphalt pavement as shown in the Plans, the Contractor shall take extra precaution to make a neat, uniform cut, and shall sawcut pavement to full depth, regardless of number of passes necessary. If, in the opinion of the engineer, the cut is not satisfactory due to Contractor’s workmanship or equipment, the Contractor shall fix the problem to the satisfaction of the engineer, at Contractor’s own expense.

2-02.4 Measurement

Supplement

Section 2-02.4 is supplemented with the following:

Sawcutting existing cement and asphalt concrete pavements will be measured by the linear foot along the sawcut, full depth. Recutting of edges for pavement patching will not be measured for payment unless the Engineer has directed the Contractor to either widen or increase the depth of the trench such that additional sawcutting and pavement removal is required for pavement patching.

Wheelcutting of pavement will not be measured for separate payment, but shall be included in other items of work.

2-02.5 Payment

Supplement

Section 2-02.5 is supplemented with the following:

Payment will be made for the following bid items:

Removing of Structure and Obstructions	Lump Sum
Sawcutting	Per Linear Foot

The lump sum price for “Removal of Structure and Obstructions” shall also include backfill and compaction as required.

Demolition, removal, and disposal of all other structures and obstructions not covered under other bid items shall be included in the lump sum price for “Removal of Structure and Obstructions”, including but not limited to: abandoning utilities, abandonment and plugging of pipe, removal of pavement markings, existing posts, extruded curb, signs and supports, and removal of other miscellaneous street improvements.

The unit contract price per linear foot of "Sawcut" shall be full pay for a full depth sawcut at intersecting roadways, driveways, and parking areas. Sawcutting for the purpose of pipe installation shall be included in the respective pipe unit bid items.

END OF DIVISION 2

DIVISION 3 PRODUCTION FROM QUARRY AND PIT SITES AND STOCKPILING

3-01 PRODUCTION FROM QUARRY AND PIT SITES

3-01.4 Contractor-Furnished Material Sources

Supplement

Section 3-01.4 is supplemented with the following:

No source has been provided for any materials necessary for the construction of this improvement.

If the sources of materials provided by the Contractor necessitate hauling over roads other than city streets, the Contractor shall, at his own cost and expense, make all arrangements for the use of the haul routes.

3-01.6 Payment

Replacement

Delete Section 3-01.6 and replace it with the following:

All work covered under Division 3, which is performed by the Contractor, shall be considered included in the costs for furnishing of materials. All costs of acquiring, producing, and placing this material in the finished work shall be included in the unit and lump sum contract prices for the various items involved.

END OF DIVISION 3

DIVISION 4 BASES

4-04 BALLAST AND CRUSHED SURFACING

4-04.1 Description *Supplement*

Section 4-04.1 is supplemented with the following:

Crushed surfacing shall be placed where shown in the Plans, as a base for sidewalks, driveways, and pavement, at existing driveways to provide temporary access, as backfill for unsuitable foundation excavation, at mailbox supports, or for any other purposes deemed necessary by the Engineer.

4-04.4 Measurement *Supplement*

Section 4-04.4 is supplemented with the following:

Stockpiling of crushed surfacing materials shall not be allowed. Crushed surfacing materials used as a base course for drainage pipes and structures, driveway or project maintenance, pipe zone bedding, replacement of over excavated material performed in lieu of shoring or unauthorized over excavation will not be measured for payment and shall be considered incidental to other bid items.

Crushed surfacing materials used for temporary access and maintenance as required under Section 1-07.23(1) of the Standard Specifications **will not be measured for payment** unless it is placed to final grades and maintained as such until paving.

Should the Contractor not prepare subgrade to the correct line and grades and crushed surfacing materials are placed in excess to the depth required by the plans, the excess depth will not be measured for payment but instead be considered to benefit the Contractor. The crushed surfacing materials shall be measured by neat line and that measurement converted to tons for deduction of payment.

4-04.5 Payment *Supplement*

Section 4-04.5 is supplemented with the following:

Payment will be made for the following bid item:

Crushed Surfacing Top Course	Per Ton
------------------------------	---------

The unit contract price per ton for “Crushed Surfacing Top Course” shall also include furnishing, hauling, compacting, and removing and hauling to waste, when required by the Engineer. Quantities have been entered in the proposal for “Crushed Surfacing Top Course” for bidding purposes only. This item is not subject to the provisions of Section 1-04.6 of the standard specifications.

“Crushed Surfacing Top Course” utilized for purposes other than roadway, sidewalk, or driveway construction will not be measured and paid under the “Crushed Surfacing Top Course” item, and shall be included in other bid items.

END OF DIVISION 4

DIVISION 5 SURFACE TREATMENTS AND PAVEMENTS

5-04 HOT MIX ASPHALT

5-04 Hot Mix Asphalt

Replacement

(January 31, 2023 APWA GSP)

Delete Section 5-04 and amendments, Hot Mix Asphalt and replace it with the following:

5-04.1 Description

This Work shall consist of providing and placing one or more layers of plant-mixed hot mix asphalt (HMA) on a prepared foundation or base in accordance with these Specifications and the lines, grades, thicknesses, and typical cross-sections shown in the Plans. The manufacture of HMA may include warm mix asphalt (WMA) processes in accordance with these Specifications. WMA processes include organic additives, chemical additives, and foaming.

HMA shall be composed of asphalt binder and mineral materials as may be required, mixed in the proportions specified to provide a homogeneous, stable, and workable mixture.

5-04.2 Materials

Materials shall meet the requirements of the following sections:

Asphalt Binder	9-02.1(4)
Cationic Emulsified Asphalt	9-02.1(6)
Anti-Stripping Additive	9-02.4
HMA Additive	9-02.5
Aggregates	9-03.8
Recycled Asphalt Pavement (RAP)	9-03.8(3)B, 9-03.21
Reclaimed Asphalt Shingles (RAS)	9-03.8(3)B, 9-03.21
Mineral Filler	9-03.8(5)
Recycled Material	9-03.21

The Contract documents may establish that the various mineral materials required for the manufacture of HMA will be furnished in whole or in part by the Contracting Agency. If the documents do not establish the furnishing of any of these mineral materials by the Contracting Agency, the Contractor shall be required to furnish such materials in the amounts required for the designated mix. Mineral materials include coarse and fine aggregates, and mineral filler.

The Contractor may choose to utilize recycled asphalt pavement (RAP) in the production of HMA. The RAP may be from pavements removed under the Contract, if any, or pavement material from an existing stockpile.

The Contractor may use up to 20 percent RAP by total weight of HMA with no additional sampling or testing of the RAP.

If the Contractor wishes to utilize High RAP/Any RAS, the design must be listed on the WSDOT Qualified Products List (QPL).

The grade of asphalt binder shall be as required by the Contract. Blending of asphalt binder from different sources is not permitted.

The Contractor may only use warm mix asphalt (WMA) processes in the production of HMA with 20 percent or less RAP by total weight of HMA. The Contractor shall submit to the Engineer for approval the process that is proposed and how it will be used in the manufacture of HMA.

Production of aggregates shall comply with the requirements of Section 3-01. Preparation of stockpile site, the stockpiling of aggregates, and the removal of aggregates from stockpiles shall comply with the requirements of Section 3-02.

5-04.2(1) How to Get an HMA Mix Design on the QPL

If the Contractor wishes to submit a mix design for inclusion in the Qualified Products List (QPL), please follow the WSDOT process outlined in Standard Specification 5-04.2(1).

5-04.2(1)A Vacant

5-04.2(2) Mix Design - Obtaining Project Approval

No paving shall begin prior to the approval of the mix design by the Engineer.

Nonstatistical evaluation will be used for all HMA not designated as Commercial HMA in the Contract documents.

Commercial evaluation will be used for Commercial HMA and for other classes of HMA in the following applications: sidewalks, road approaches, ditches, slopes, paths, trails, gores, prelevel, temporary pavement, and pavement repair. Other nonstructural applications of HMA accepted by commercial evaluation shall be as approved by the Project Engineer. Sampling and testing of HMA accepted by commercial evaluation will be at the option of the Project Engineer. The Proposal quantity of HMA that is accepted by commercial evaluation will be excluded from the quantities used in the determination of nonstatistical evaluation.

Nonstatistical Mix Design. Fifteen days prior to the first day of paving the Contractor shall provide one of the following mix design verification certifications for Contracting Agency review;

- The WSDOT Mix Design Evaluation Report from the current WSDOT QPL, or one of the mix design verification certifications listed below.
- The proposed HMA mix design on WSDOT Form 350-042 with the seal and certification (stamp & signature) of a valid licensed Washington State Professional Engineer.
- The Mix Design Report for the proposed HMA mix design developed by a qualified City or County laboratory that is within one year of the approval date.

The mix design shall be performed by a lab accredited by a national authority such as Laboratory Accreditation Bureau, L-A-B for Construction Materials Testing, The Construction Materials Engineering Council (CMEC's) ISO 17025 or AASHTO Accreditation Program (AAP) and shall supply evidence of participation in the AASHTO: resource proficiency sample program.

Mix designs for HMA accepted by Nonstatistical evaluation shall:

- Be designed for 2.9 million equivalent single axle loads (ESALs).
- Have the aggregate structure and asphalt binder content determined in accordance with WSDOT Standard Operating Procedure 732 and meet the requirements of Sections 9-03.8(2), except that Hamburg testing for ruts and stripping are at the discretion of the Engineer, and 9-03.8(6).
- Have anti-strip requirements, if any, for the proposed mix design determined in accordance with AASHTO T 283 or T 324 or based on historic anti-strip and aggregate source compatibility from previous WSDOT lab testing.

At the discretion of the Engineer, agencies may accept verified mix designs older than 12 months from the original verification date with a certification from the Contractor that the materials and sources are the same as those shown on the original mix design.

Commercial Evaluation Mix Design. Approval of a mix design for "Commercial Evaluation" will be based on a review of the Contractor's submittal of WSDOT Form 350-042 (for commercial mixes, AASHTO T 324 evaluation is not required) or a Mix Design from the current WSDOT QPL or from one of the processes allowed by this section. Testing of the HMA by the Contracting Agency for mix design approval is not required.

For the Bid Item Commercial HMA, the Contractor shall select a class of HMA and design level of ESALs appropriate for the required use.

5-04.2(2)B Using Warm Mix Asphalt Processes

The Contractor may elect to use additives that reduce the optimum mixing temperature or serve as a compaction aid for producing HMA. Additives include organic additives, chemical additives and foaming processes. The use of Additives is subject to the following:

- Do not use additives that reduce the mixing temperature more than allowed in Section 5-04.3(6) in the production of mixtures.
- Before using additives, obtain the Engineer’s approval using WSDOT Form 350-076 to describe the proposed additive and process.

5-04.3 Construction Requirements

5-04.3(1) Weather Limitations

Do not place HMA for wearing course on any Traveled Way beginning October 1st through March 31st of the following year without written concurrence from the Engineer.

Do not place HMA on any wet surface, or when the average surface temperatures are less than those specified below, or when weather conditions otherwise prevent the proper handling or finishing of the HMA.

Minimum Surface Temperature for Paving

Compacted Thickness (feet)	Wearing Course	Other Courses
Less than 0.10	55°F	45°F
0.10 to .20	45°F	35°F
More than 0.20	35°F	35°F

5-04.3(2) Paving Under Traffic

When the Roadway being paved is open to traffic, the requirements of this Section shall apply.

The Contractor shall keep intersections open to traffic at all times except when paving the intersection or paving across the intersection. During such time, and provided that there has been an advance warning to the public, the intersection may be closed for the minimum time required to place and compact the mixture. In hot weather, the Engineer may require the application of water to the pavement to accelerate the finish rolling of the pavement and to shorten the time required before reopening to traffic.

Before closing an intersection, advance warning signs shall be placed, and signs shall also be placed marking the detour or alternate route.

During paving operations, temporary pavement markings shall be maintained throughout the project. Temporary pavement markings shall be installed on the Roadway prior to opening to traffic. Temporary pavement markings shall be in accordance with Section 8-23.

All costs in connection with performing the Work in accordance with these requirements, except the cost of temporary pavement markings, shall be included in the unit Contract prices for the various Bid items involved in the Contract.

5-04.3(3) Equipment

5-04.3(3)A Mixing Plant

Plants used for the preparation of HMA shall conform to the following requirements:

1. **Equipment for Preparation of Asphalt Binder** – Tanks for the storage of asphalt binder shall be equipped to heat and hold the material at the required temperatures. The heating shall be accomplished by steam coils, electricity, or other approved means so that no flame shall be in contact with the storage tank. The circulating system for the asphalt binder shall be designed to ensure proper and continuous circulation during the operating period. A valve for the purpose of sampling the asphalt binder shall be placed in either the storage tank or in the supply line to the mixer.
2. **Thermometric Equipment** – An armored thermometer, capable of detecting temperature ranges expected in the HMA mix, shall be fixed in the asphalt binder feed line at a location near the charging valve at the mixer unit. The thermometer location shall be convenient and safe for access by Inspectors. The plant shall also be equipped with an approved dial-scale thermometer, a mercury actuated thermometer, an electric pyrometer, or another approved thermometric instrument placed at the discharge chute of the drier to automatically register or indicate the temperature of the heated aggregates. This device shall be in full view of the plant operator.
3. **Heating of Asphalt Binder** – The temperature of the asphalt binder shall not exceed the maximum recommended by the asphalt binder manufacturer nor shall it be below the minimum temperature required to maintain the asphalt binder in a homogeneous state. The asphalt binder shall be heated in a manner that will avoid local variations in heating. The heating method shall provide a continuous supply of asphalt binder to the mixer at a uniform average temperature with no individual variations exceeding 25°F. Also, when a WMA additive is included in the asphalt binder, the temperature of the asphalt binder shall not exceed the maximum recommended by the manufacturer of the WMA additive.
4. **Sampling and Testing of Mineral Materials** – The HMA plant shall be equipped with a mechanical sampler for the sampling of the mineral materials. The mechanical sampler shall meet the requirements of Section 1-05.6 for the crushing and screening operation. The Contractor shall provide for the setup and operation of the field-testing facilities of the Contracting Agency as provided for in Section 3-01.2(2).

5. **Sampling HMA** – The HMA plant shall provide for sampling HMA by one of the following methods:
 - a. A mechanical sampling device attached to the HMA plant.
 - b. Platforms or devices to enable sampling from the hauling vehicle without entering the hauling vehicle.

5-04.3(3)B Hauling Equipment

Trucks used for hauling HMA shall have tight, clean, smooth metal beds and shall have a cover of canvas or other suitable material of sufficient size to protect the mixture from adverse weather. Whenever the weather conditions during the work shift include, or are forecast to include precipitation or an air temperature less than 45°F or when time from loading to unloading exceeds 30 minutes, the cover shall be securely attached to protect the HMA.

The Contractor shall provide an environmentally benign means to prevent the HMA mixture from adhering to the hauling equipment. Excess release agent shall be drained prior to filling hauling equipment with HMA. Petroleum derivatives or other coating material that contaminate or alter the characteristics of the HMA shall not be used. For live bed trucks, the conveyor shall be in operation during the process of applying the release agent.

5-04.3(3)C Pavers

HMA pavers shall be self-contained, power-propelled units, provided with an internally heated vibratory screed and shall be capable of spreading and finishing courses of HMA plant mix material in lane widths required by the paving section shown in the Plans.

The HMA paver shall be in good condition and shall have the most current equipment available from the manufacturer for the prevention of segregation of the HMA mixture installed, in good condition, and in working order. The equipment certification shall list the make, model, and year of the paver and any equipment that has been retrofitted.

The screed shall be operated in accordance with the manufacturer's recommendations and shall effectively produce a finished surface of the required evenness and texture without tearing, shoving, segregating, or gouging the mixture. A copy of the manufacturer's recommendations shall be provided upon request by the Contracting Agency. Extensions will be allowed provided they produce the same results, including ride, density, and surface texture as obtained by the primary screed. Extensions without augers and an internally heated vibratory screed shall not be used in the Traveled Way.

When specified in the Contract, reference lines for vertical control will be required. Lines shall be placed on both outer edges of the Traveled Way of each Roadway. Horizontal control utilizing the reference line will be permitted. The grade and slope for intermediate

lanes shall be controlled automatically from reference lines or by means of a mat referencing device and a slope control device. When the finish of the grade prepared for paving is superior to the established tolerances and when, in the opinion of the Engineer, further improvement to the line, grade, cross-section, and smoothness can best be achieved without the use of the reference line, a mat referencing device may be substituted for the reference line. Substitution of the device will be subject to the continued approval of the Engineer. A joint matcher may be used subject to the approval of the Engineer. The reference line may be removed after the completion of the first course of HMA when approved by the Engineer. Whenever the Engineer determines that any of these methods are failing to provide the necessary vertical control, the reference lines will be reinstalled by the Contractor.

The Contractor shall furnish and install all pins, brackets, tensioning devices, wire, and accessories necessary for satisfactory operation of the automatic control equipment.

If the paving machine in use is not providing the required finish, the Engineer may suspend Work as allowed by Section 1-08.6. Any cleaning or solvent type liquids spilled on the pavement shall be thoroughly removed before paving proceeds.

5-04.3(3)D Material Transfer Device or Material Transfer Vehicle

A Material Transfer Device/Vehicle (MTD/V) shall only be used with the Engineer's approval, unless otherwise required by the Contract.

Where an MTD/V is required by the Contract, the Engineer may approve paving without an MTD/V, at the request of the Contractor. The Engineer will determine if an equitable adjustment in cost or time is due.

When used, the MTD/V shall mix the HMA after delivery by the hauling equipment and prior to laydown by the paving machine. Mixing of the HMA shall be sufficient to obtain a uniform temperature throughout the mixture. If a windrow elevator is used, the length of the windrow may be limited in urban areas or through intersections, at the discretion of the Engineer.

To be approved for use, an MTV:

1. Shall be self-propelled vehicle, separate from the hauling vehicle or paver.
2. Shall not be connected to the hauling vehicle or paver.
3. May accept HMA directly from the haul vehicle or pick up HMA from a windrow.
4. Shall mix the HMA after delivery by the hauling equipment and prior to placement into the paving machine.

5. Shall mix the HMA sufficiently to obtain a uniform temperature throughout the mixture.

To be approved for use, an MTD:

1. Shall be positively connected to the paver.
2. May accept HMA directly from the haul vehicle or pick up HMA from a windrow.
3. Shall mix the HMA after delivery by the hauling equipment and prior to placement into the paving machine.
4. Shall mix the HMA sufficiently to obtain a uniform temperature throughout the mixture.

5-04.3(3)E Rollers

Rollers shall be of the steel wheel, vibratory, oscillatory, or pneumatic tire type, in good condition and capable of reversing without backlash. Operation of the roller shall be in accordance with the manufacturer's recommendations. When ordered by the Engineer for any roller planned for use on the project, the Contractor shall provide a copy of the manufacturer's recommendation for the use of that roller for compaction of HMA. The number and weight of rollers shall be sufficient to compact the mixture in compliance with the requirements of Section 5-04.3(10). The use of equipment that results in crushing of the aggregate will not be permitted. Rollers producing pickup, washboard, uneven compaction of the surface, displacement of the mixture or other undesirable results shall not be used.

5-04.3(4) Preparation of Existing Paved Surfaces

When the surface of the existing pavement or old base is irregular, the Contractor shall bring it to a uniform grade and cross-section as shown on the Plans or approved by the Engineer.

Preleveling of uneven or broken surfaces over which HMA is to be placed may be accomplished by using an asphalt paver, a motor patrol grader, or by hand raking, as approved by the Engineer.

Compaction of preleveling HMA shall be to the satisfaction of the Engineer and may require the use of small steel wheel rollers, plate compactors, or pneumatic rollers to avoid bridging across preleveled areas by the compaction equipment. Equipment used for the compaction of preleveling HMA shall be approved by the Engineer.

Before construction of HMA on an existing paved surface, the entire surface of the pavement shall be clean. All fatty asphalt patches, grease drippings, and other objectionable matter shall be entirely removed from the existing pavement. All pavements or bituminous surfaces shall be thoroughly cleaned of dust, soil, pavement grindings, and other foreign

matter. All holes and small depressions shall be filled with an appropriate class of HMA. The surface of the patched area shall be leveled and compacted thoroughly. Prior to the application of tack coat, or paving, the condition of the surface shall be approved by the Engineer.

A tack coat of asphalt shall be applied to all paved surfaces on which any course of HMA is to be placed or abutted; except that tack coat may be omitted from clean, newly paved surfaces at the discretion of the Engineer. Tack coat shall be uniformly applied to cover the existing pavement with a thin film of residual asphalt free of streaks and bare spots at a rate between 0.02 and 0.10 gallons per square yard of retained asphalt. The rate of application shall be approved by the Engineer. A heavy application of tack coat shall be applied to all joints. For Roadways open to traffic, the application of tack coat shall be limited to surfaces that will be paved during the same working shift. The spreading equipment shall be equipped with a thermometer to indicate the temperature of the tack coat material.

Equipment shall not operate on tacked surfaces until the tack has broken and cured. If the Contractor's operation damages the tack coat it shall be repaired prior to placement of the HMA.

The tack coat shall be CSS-1, or CSS-1h emulsified asphalt. The CSS-1 and CSS-1h emulsified asphalt may be diluted once with water at a rate not to exceed one-part water to one-part emulsified asphalt. The tack coat shall have sufficient temperature such that it may be applied uniformly at the specified rate of application and shall not exceed the maximum temperature recommended by the emulsified asphalt manufacturer.

5-04.3(4)A Crack Sealing

When the Proposal includes a pay item for crack sealing, seal cracks in accordance with Section 5-03.

5-04.3(4)B Vacant

5-04.3(4)C Pavement Repair

The Contractor shall excavate pavement repair areas and shall backfill these with HMA in accordance with the details shown in the Plans and as marked in the field. The Contractor shall conduct the excavation operations in a manner that will protect the pavement that is to remain. Pavement not designated to be removed that is damaged as a result of the Contractor's operations shall be repaired by the Contractor to the satisfaction of the Engineer at no cost to the Contracting Agency. The Contractor shall excavate only within one lane at a time unless approved otherwise by the Engineer. The Contractor shall not excavate more area than can be completely finished during the same shift, unless approved by the Engineer.

Unless otherwise shown in the Plans or determined by the Engineer, excavate to a depth of 1.0 feet. The Engineer will make the final determination of the excavation depth required. The minimum width of any pavement repair area shall be 40 inches unless shown otherwise

in the Plans. Before any excavation, the existing pavement shall be sawcut or shall be removed by a pavement grinder. Excavated materials will become the property of the Contractor and shall be disposed of in a Contractor-provided site off the Right of Way or used in accordance with Sections 2-02.3(3) or 9-03.21.

Asphalt for tack coat shall be required as specified in Section 5-04.3(4). A heavy application of tack coat shall be applied to all surfaces of existing pavement in the pavement repair area.

Placement of the HMA backfill shall be accomplished in lifts not to exceed 0.35-foot compacted depth. Lifts that exceed 0.35-foot of compacted depth may be accomplished with the approval of the Engineer. Each lift shall be thoroughly compacted by a mechanical tamper or a roller.

5-04.3(5) Producing/Stockpiling Aggregates and RAP

Aggregates and RAP shall be stockpiled according to the requirements of Section 3-02. Sufficient storage space shall be provided for each size of aggregate and RAP. Materials shall be removed from stockpile(s) in a manner to ensure minimal segregation when being moved to the HMA plant for processing into the final mixture. Different aggregate sizes shall be kept separated until they have been delivered to the HMA plant.

5-04.3(5)A Vacant

5-04.3(6) Mixing

After the required amount of mineral materials, asphalt binder, recycling agent and anti-stripping additives have been introduced into the mixer the HMA shall be mixed until complete and uniform coating of the particles and thorough distribution of the asphalt binder throughout the mineral materials is ensured.

When discharged, the temperature of the HMA shall not exceed the optimum mixing temperature by more than 25°F as shown on the reference mix design report or as approved by the Engineer. Also, when a WMA additive is included in the manufacture of HMA, the discharge temperature of the HMA shall not exceed the maximum recommended by the manufacturer of the WMA additive. A maximum water content of 2 percent in the mix, at discharge, will be allowed providing the water causes no problems with handling, stripping, or flushing. If the water in the HMA causes any of these problems, the moisture content shall be reduced as directed by the Engineer.

Storing or holding of the HMA in approved storage facilities will be permitted with approval of the Engineer, but in no event shall the HMA be held for more than 24 hours. HMA held for more than 24 hours after mixing shall be rejected. Rejected HMA shall be disposed of by the Contractor at no expense to the Contracting Agency. The storage facility shall have an accessible device located at the top of the cone or about the third point. The device shall indicate the amount of material in storage. No HMA shall be accepted from the storage

facility when the HMA in storage is below the top of the cone of the storage facility, except as the storage facility is being emptied at the end of the working shift.

Recycled asphalt pavement (RAP) utilized in the production of HMA shall be sized prior to entering the mixer so that a uniform and thoroughly mixed HMA is produced. If there is evidence of the recycled asphalt pavement not breaking down during the heating and mixing of the HMA, the Contractor shall immediately suspend the use of the RAP until changes have been approved by the Engineer. After the required amount of mineral materials, RAP, new asphalt binder and asphalt rejuvenator have been introduced into the mixer the HMA shall be mixed until complete and uniform coating of the particles and thorough distribution of the asphalt binder throughout the mineral materials, and RAP is ensured.

5-04.3(7) Spreading and Finishing

The mixture shall be laid upon an approved surface, spread, and struck off to the grade and elevation established. HMA pavers complying with Section 5-04.3(3) shall be used to distribute the mixture. Unless otherwise directed by the Engineer, the nominal compacted depth of any layer of any course shall not exceed the following:

HMA Class 1"	0.35 feet
HMA Class ¾" and HMA Class ½"	
wearing course	0.30 feet
other courses	0.35 feet
HMA Class ⅜"	0.15 feet

On areas where irregularities or unavoidable obstacles make the use of mechanical spreading and finishing equipment impractical, the paving may be done with other equipment or by hand.

When more than one JMF is being utilized to produce HMA, the material produced for each JMF shall be placed by separate spreading and compacting equipment. The intermingling of HMA produced from more than one JMF is prohibited. Each strip of HMA placed during a work shift shall conform to a single JMF established for the class of HMA specified unless there is a need to make an adjustment in the JMF.

5-04.3(8) Aggregate Acceptance Prior to Incorporation in HMA

For HMA accepted by nonstatistical evaluation, the aggregate properties of sand equivalent, uncompacted void content, and fracture will be evaluated in accordance with Section 3-04. Sampling and testing of aggregates for HMA accepted by commercial evaluation will be at the option of the Engineer.

5-04.3(9) HMA Mixture Acceptance

Acceptance of HMA shall be as provided under nonstatistical, or commercial evaluation.

Nonstatistical evaluation will be used for the acceptance of HMA unless Commercial Evaluation is specified.

Commercial evaluation will be used for Commercial HMA and for other classes of HMA in the following applications: sidewalks, road approaches, ditches, slopes, paths, trails, gores, prelevel, temporary pavement, and pavement repair. Other nonstructural applications of HMA accepted by commercial evaluation shall be as approved by the Engineer. Sampling and testing of HMA accepted by commercial evaluation will be at the option of the Engineer.

The mix design will be the initial JMF for the class of HMA. The Contractor may request a change in the JMF. Any adjustments to the JMF will require the approval of the Engineer and may be made in accordance with this section.

HMA Tolerances and Adjustments

1. **Job Mix Formula Tolerances** – The constituents of the mixture at the time of acceptance shall be within tolerance. The tolerance limits will be established as follows:

For Asphalt Binder and Air Voids (Va), the acceptance limits are determined by adding the tolerances below to the approved JMF values. These values will also be the Upper Specification Limit (USL) and Lower Specification Limit (LSL) required in Section 1-06.2(2)D2

Property	Non-Statistical Evaluation	Commercial Evaluation
Asphalt Binder	+/- 0.5%	+/- 0.7%
Air Voids, Va	2.5% min, and 5.5% max.	N/A

For Aggregates in the mixture:

- a. First, determine preliminary upper and lower acceptance limits by applying the following tolerances to the approved JMF.

Aggregate Percent Passing	Non-Statistical Evaluation	Commercial Evaluation
1", 3/4", 1/2", and 3/8" sieves	+/- 6%	+/- 8%
No. 4 sieve	+/-6%	+/-8%
No. 8 Sieve	+/-6%	+/-8%
No. 200 sieve	+/- 2.0%	+/-3.0%

- b. Second, adjust the preliminary upper and lower acceptance limits determined from step (a) the minimum amount necessary so that none of the aggregate properties are outside the control points in Section 9-03.8(6). The resulting values will be the upper and lower acceptance limits for aggregates, as well as the USL and LSL required in Section 1-06.2(2)D2.
2. Job Mix Formula Adjustments – An adjustment to the aggregate gradation or asphalt binder content of the JMF requires approval of the Engineer. Adjustments to the JMF will only be considered if the change produces material of equal or better quality and may require the development of a new mix design if the adjustment exceeds the amounts listed below.
 - a. **Aggregates** –2 percent for the aggregate passing the 1½", 1", ¾", ½", ⅜", and the No. 4 sieves, 1 percent for aggregate passing the No. 8 sieve, and 0.5 percent for the aggregate passing the No. 200 sieve. The adjusted JMF shall be within the range of the control points in Section 9-03.8(6).
 - b. **Asphalt Binder Content** – The Engineer may order or approve changes to asphalt binder content. The maximum adjustment from the approved mix design for the asphalt binder content shall be 0.3 percent.

5-04.3(9)A Vacant

5-04.3(9)B Vacant

5-04.3(9)C Mixture Acceptance – Nonstatistical Evaluation

HMA mixture which is accepted by Nonstatistical Evaluation will be evaluated by the Contracting Agency by dividing the HMA tonnage into lots.

5-04.3(9)C1 Mixture Nonstatistical Evaluation – Lots and Sublots

A lot is represented by randomly selected samples of the same mix design that will be tested for acceptance. A lot is defined as the total quantity of material or work produced for each Job Mix Formula placed. Only one lot per JMF is expected. A subplot shall be equal to one day's production or 800 tons, whichever is less except that the final subplot will be a minimum of 400 tons and may be increased to 1200 tons.

All of the test results obtained from the acceptance samples from a given lot shall be evaluated collectively. If the Contractor requests a change to the JMF that is approved, the material produced after the change will be evaluated on the basis of the new JMF for the remaining sublots in the current lot and for acceptance of subsequent lots. For a lot in progress with a CPF less than 0.75, a new lot will begin at the Contractor's request after the Engineer is satisfied that material conforming to the Specifications can be produced.

Sampling and testing for evaluation shall be performed on the frequency of one sample per subplot.

5-04.3(9)C2 Mixture Nonstatistical Evaluation Sampling

Samples for acceptance testing shall be obtained by the Contractor when ordered by the Engineer. The Contractor shall sample the HMA mixture in the presence of the Engineer and in accordance with AASH-TO T 168. A minimum of three samples should be taken for each class of HMA placed on a project. If used in a structural application, at least one of the three samples shall be tested.

Sampling and testing HMA in a structural application where quantities are less than 400 tons is at the discretion of the Engineer.

For HMA used in a structural application and with a total project quantity less than 800 tons but more than 400 tons, a minimum of one acceptance test shall be performed. In all cases, a minimum of 3 samples will be obtained at the point of acceptance, a minimum of one of the three samples will be tested for conformance to the JMF:

- If the test results are found to be within specification requirements, additional testing will be at the Engineer's discretion.
- If test results are found not to be within specification requirements, additional testing of the remaining samples to determine a CPF shall be performed.

5-04.3(9)C3 Mixture Nonstatistical Evaluation – Acceptance Testing

Testing of HMA for compliance of V_a will at the option of the Contracting Agency. If tested, compliance of V_a will use WSDOT SOP 731.

Testing for compliance of asphalt binder content will be by WSDOT FOP for AASHTO T 308.

Testing for compliance of gradation will be by FOP for WAQTC T 27/T 11.

5-04.3(9)C4 Mixture Nonstatistical Evaluation – Pay Factors

For each lot of material falling outside the tolerance limits in 5-04.3(9), the Contracting Agency will determine a CPF using the following price adjustment factors:

Table of Price Adjustment Factors	
Constituent	Factor "f"
All aggregate passing: 1½", 1", ¾", ½", ⅜" and No.4 sieves	2
All aggregate passing No. 8 sieve	15
All aggregate passing No. 200 sieve	20
Asphalt binder	40
Air Voids (Va) (where applicable)	20

Each lot of HMA produced under Nonstatistical Evaluation and having all constituents falling within the tolerance limits of the job mix formula shall be accepted at the unit Contract price with no further evaluation. When one or more constituents fall outside the nonstatistical tolerance limits in the Job Mix Formula shown in Table of Price Adjustment Factors, the lot shall be evaluated in accordance with Section 1-06.2 to determine the appropriate CPF. The nonstatistical tolerance limits will be used in the calculation of the CPF and the maximum CPF shall be 1.00. When less than three sublots exist, backup samples of the existing sublots or samples from the Roadway shall be tested to provide a minimum of three sets of results for evaluation.

5-04.3(9)C5 Vacant

5-04.3(9)C6 Mixture Nonstatistical Evaluation – Price Adjustments

For each lot of HMA mix produced under Nonstatistical Evaluation when the calculated CPF is less than 1.00, a Nonconforming Mix Factor (NCMF) will be determined. The NCMF equals the algebraic difference of CPF minus 1.00 multiplied by 60 percent. The total job mix compliance price adjustment will be calculated as the product of the NCMF, the quantity of HMA in the lot in tons, and the unit Contract price per ton of mix.

If a constituent is not measured in accordance with these Specifications, its individual pay factor will be considered 1.00 in calculating the CPF.

5-04.3(9)C7 Mixture Nonstatistical Evaluation - Retests

The Contractor may request a subplot be retested. To request a retest, the Contractor shall submit a written request within 7 calendar days after the specific test results have been received. A split of the original acceptance sample will be retested. The split of the sample will not be tested with the same tester that ran the original acceptance test. The sample will be tested for a complete gradation analysis, asphalt binder content, and, at the option of the agency, Va. The results of the retest will be used for the acceptance of the HMA in place of the original subplot sample test results. The cost of testing will be deducted from any monies due or that may come due the Contractor under the Contract at the rate of \$500 per sample.

5-04.3 (9)D Mixture Acceptance – Commercial Evaluation

If sampled and tested, HMA produced under Commercial Evaluation and having all constituents falling within the tolerance limits of the job mix formula shall be accepted at the unit Contract price with no further evaluation. When one or more constituents fall outside the commercial tolerance limits in the Job Mix Formula shown in 5-04.3(9), the lot shall be evaluated in accordance with Section 1-06.2 to determine the appropriate CPF. The commercial tolerance limits will be used in the calculation of the CPF and the maximum CPF shall be 1.00. When less than three sublots exist, backup samples of the existing sublots or samples from the street shall be tested to provide a minimum of three sets of results for evaluation.

For each lot of HMA mix produced and tested under Commercial Evaluation when the calculated CPF is less than 1.00, a Nonconforming Mix Factor (NCMF) will be determined. The NCMF equals the algebraic difference of CPF minus 1.00 multiplied by 60 percent. The Job Mix Compliance Price Adjustment will be calculated as the product of the NCMF, the quantity of HMA in the lot in tons, and the unit Contract price per ton of mix.

If a constituent is not measured in accordance with these Specifications, its individual pay factor will be considered 1.00 in calculating the CPF.

5-04.3(10) HMA Compaction Acceptance

HMA mixture accepted by nonstatistical evaluation that is used in traffic lanes, including lanes for intersections, ramps, truck climbing, weaving, and speed change, and having a specified compacted course thickness greater than 0.10-foot, shall be compacted to a specified level of relative density. The specified level of relative density shall be a CPF of not less than 0.75 when evaluated in accordance with Section 1-06.2, using a LSL of 92.0 (minimum of 92 percent of the maximum density). The maximum density shall be determined by WSDOT FOP for AASHTO T 729. The specified level of density attained will be determined by the evaluation of the density of the pavement. The density of the pavement shall be determined in accordance with WSDOT FOP for WAQTC TM 8, except that gauge correlation will be at the discretion of the Engineer, when using the nuclear density gauge and WSDOT SOP 736 when using cores to determine density.

Tests for the determination of the pavement density will be taken in accordance with the required procedures for measurement by a nuclear density gauge or Roadway cores after completion of the finish rolling.

If the Contracting Agency uses a nuclear density gauge to determine density the test procedures FOP for WAQTC TM 8 and WSDOT SOP T 729 will be used on the day the mix is placed and prior to opening to traffic.

Roadway cores for density may be obtained by either the Contracting Agency or the Contractor in accordance with WSDOT SOP 734. The core diameter shall be 4-inches

minimum, unless otherwise approved by the Engineer. Roadway cores will be tested by the Contracting Agency in accordance with WSDOT FOP for AASHTO T 166.

If the Contract includes the Bid item “Roadway Core”, the cores shall be obtained by the Contractor in the presence of the Engineer on the same day the mix is placed and at locations designated by the Engineer. If the Contract does not include the Bid item “Roadway Core”, the Contracting Agency will obtain the cores.

For a lot in progress with a CPF less than 0.75, a new lot will begin at the Contractor’s request after the Engineer is satisfied that material conforming to the Specifications can be produced.

HMA mixture accepted by commercial evaluation and HMA constructed under conditions other than those listed above shall be compacted on the basis of a test point evaluation of the compaction train. The test point evaluation shall be performed in accordance with instructions from the Engineer. The number of passes with an approved compaction train, required to attain the maximum test point density, shall be used on all subsequent paving.

HMA for preleveling shall be thoroughly compacted. HMA that is used for preleveling wheel rutting shall be compacted with a pneumatic tire roller unless otherwise approved by the Engineer.

Test Results

For a subplot that has been tested with a nuclear density gauge that did not meet the minimum of 92 percent of the reference maximum density in a compaction lot with a CPF below 1.00 and thus subject to a price reduction or rejection, the Contractor may request that a core be used for determination of the relative density of the subplot. The relative density of the core will replace the relative density determined by the nuclear density gauge for the subplot and will be used for calculation of the CPF and acceptance of HMA compaction lot.

When cores are taken by the Contracting Agency at the request of the Contractor, they shall be requested by noon of the next workday after the test results for the subplot have been provided or made available to the Contractor. Core locations shall be outside of wheel paths and as determined by the Engineer. Traffic control shall be provided by the Contractor as requested by the Engineer. Failure by the Contractor to provide the requested traffic control will result in forfeiture of the request for cores. When the CPF for the lot based on the results of the HMA cores is less than 1.00, the cost for the coring will be deducted from any monies due or that may become due the Contractor under the Contract at the rate of \$200 per core and the Contractor shall pay for the cost of the traffic control.

5-04.3(10)A HMA Compaction – General Compaction Requirements

Compaction shall take place when the mixture is in the proper condition so that no undue displacement, cracking, or shoving occurs. Areas inaccessible to large compaction equipment shall be compacted by other mechanical means. Any HMA that becomes loose,

broken, contaminated, shows an excess or deficiency of asphalt, or is in any way defective, shall be removed and replaced with new hot mix that shall be immediately compacted to conform to the surrounding area.

The type of rollers to be used and their relative position in the compaction sequence shall generally be the Contractor's option, provided the specified densities are attained. Unless the Engineer has approved otherwise, rollers shall only be operated in the static mode when the internal temperature of the mix is less than 175°F. Regardless of mix temperature, a roller shall not be operated in a mode that results in checking or cracking of the mat. Rollers shall only be operated in static mode on bridge decks.

5-04.3(10)B HMA Compaction - Cyclic Density

Low cyclic density areas are defined as spots or streaks in the pavement that are less than 90 percent of the theoretical maximum density. At the Engineer's discretion, the Engineer may evaluate the HMA pavement for low cyclic density, and when doing so will follow WSDOT SOP 733. A \$500 Cyclic Density Price Adjustment will be assessed for any 500-foot section with two or more density readings below 90 percent of the theoretical maximum density.

5-04.3(10)C Vacant

5-04.3(10)D HMA Nonstatistical Compaction

5-04.3(10)D1 HMA Nonstatistical Compaction - Lots and Sublots

HMA compaction which is accepted by nonstatistical evaluation will be based on acceptance testing performed by the Contracting Agency dividing the project into compaction lots.

A lot is represented by randomly selected samples of the same mix design that will be tested for acceptance. A lot is defined as the total quantity of material or work produced for each Job Mix Formula placed. Only one lot per JMF is expected. A subplot shall be equal to one day's production or 400 tons, whichever is less except that the final subplot will be a minimum of 200 tons and may be increased to 800 tons. Testing for compaction will be at the rate of 5 tests per subplot per WSDOT T 738.

The subplot locations within each density lot will be determined by the Engineer. For a lot in progress with a CPF less than 0.75, a new lot will begin at the Contractor's request after the Engineer is satisfied that material conforming to the Specifications can be produced.

HMA mixture accepted by commercial evaluation and HMA constructed under conditions other than those listed above shall be compacted on the basis of a test point evaluation of the compaction train. The test point evaluation shall be performed in accordance with instructions from the Engineer. The number of passes with an approved compaction train, required to attain the maximum test point density, shall be used on all subsequent paving.

HMA for preleveling shall be thoroughly compacted. HMA that is used to prelevel wheel ruts shall be compacted with a pneumatic tire roller unless otherwise approved by the Engineer.

5-04.3(10)D2 HMA Compaction Nonstatistical Evaluation – Acceptance Testing

The location of the HMA compaction acceptance tests will be randomly selected by the Engineer from within each subplot, with one test per subplot.

5-04.3(10)D3 HMA Nonstatistical Compaction – Price Adjustments

For each compaction lot with one or two sublots, having all sublots attain a relative density that is 92 percent of the reference maximum density the HMA shall be accepted at the unit Contract price with no further evaluation. When a subplot does not attain a relative density that is 92 percent of the reference maximum density, the lot shall be evaluated in accordance with Section 1-06.2 to determine the appropriate CPF. The maximum CPF shall be 1.00, however, lots with a calculated CPF in excess of 1.00 will be used to offset lots with CPF values below 1.00 but greater than 0.90. Lots with CPF lower than 0.90 will be evaluated for compliance per 5-04.3(11). Additional testing by either a nuclear moisture-density gauge or cores will be completed as required to provide a minimum of three tests for evaluation.

For compaction below the required 92%, a Non-Conforming Compaction Factor (NCCF) will be determined. The NCCF equals the algebraic difference of CPF minus 1.00 multiplied by 40 percent. The Compaction Price Adjustment will be calculated as the product of CPF, the quantity of HMA in the compaction control lot in tons, and the unit Contract price per ton of mix.

5-04.3(11) Reject Work

5-04.3(11)A Reject Work General

Work that is defective or does not conform to Contract requirements shall be rejected. The Contractor may propose, in writing, alternatives to removal and replacement of rejected material. Acceptability of such alternative proposals will be determined at the sole discretion of the Engineer. HMA that has been rejected is subject to the requirements in Section 1-06.2(2) and this specification, and the Contractor shall submit a corrective action proposal to the Engineer for approval.

5-04.3(11)B Rejection by Contractor

The Contractor may, prior to sampling, elect to remove any defective material and replace it with new material. Any such new material will be sampled, tested, and evaluated for acceptance.

5-04.3(11)C Rejection Without Testing (Mixture or Compaction)

The Engineer may, without sampling, reject any batch, load, or section of Roadway that appears defective. Material rejected before placement shall not be incorporated into the pavement. Any rejected section of Roadway shall be removed.

No payment will be made for the rejected materials or the removal of the materials unless the Contractor requests that the rejected material be tested. If the Contractor elects to have the rejected material tested, a minimum of three representative samples will be obtained and tested. Acceptance of rejected material will be based on conformance with the nonstatistical acceptance Specification. If the CPF for the rejected material is less than 0.75, no payment will be made for the rejected material; in addition, the cost of sampling and testing shall be borne by the Contractor. If the CPF is greater than or equal to 0.75, the cost of sampling and testing will be borne by the Contracting Agency. If the material is rejected before placement and the CPF is greater than or equal to 0.75, compensation for the rejected material will be at a CPF of 0.75. If rejection occurs after placement and the CPF is greater than or equal to 0.75, compensation for the rejected material will be at the calculated CPF with an addition of 25 percent of the unit Contract price added for the cost of removal and disposal.

5-04.3(11)D Rejection - A Partial Sublot

In addition to the random acceptance sampling and testing, the Engineer may also isolate from a normal subplot any material that is suspected of being defective in relative density, gradation or asphalt binder content. Such isolated material will not include an original sample location. A minimum of three random samples of the suspect material will be obtained and tested. The material will then be statistically evaluated as an independent lot in accordance with Section 1-06.2(2).

5-04.3(11)E Rejection - An Entire Sublot

An entire subplot that is suspected of being defective may be rejected. When a subplot is rejected a minimum of two additional random samples from this subplot will be obtained. These additional samples and the original subplot will be evaluated as an independent lot in accordance with Section 1-06.2(2).

5-04.3(11)F Rejection - A Lot in Progress

The Contractor shall shut down operations and shall not resume HMA placement until such time as the Engineer is satisfied that material conforming to the Specifications can be produced:

1. When the CPF of a lot in progress drops below 1.00 and the Contractor is taking no corrective action, or
2. When the Pay Factor (PF) for any constituent of a lot in progress drops below 0.95 and the Contractor is taking no corrective action, or
3. When either the PF for any constituent or the CPF of a lot in progress is less than 0.75.

5-04.3(11)G Rejection - An Entire Lot (Mixture or Compaction)

An entire lot with a CPF of less than 0.75 will be rejected.

5-04.3(12) Joints**5-04.3(12)A HMA Joints****5-04.3(12)A1 Transverse Joints**

The Contractor shall conduct operations such that the placing of the top or wearing course is a continuous operation or as close to continuous as possible. Unscheduled transverse joints will be allowed, and the roller may pass over the unprotected end of the freshly laid mixture only when the placement of the course must be discontinued for such a length of time that the mixture will cool below compaction temperature. When the Work is resumed, the previously compacted mixture shall be cut back to produce a slightly beveled edge for the full thickness of the course.

A temporary wedge of HMA constructed on a 20H:1V shall be constructed where a transverse joint as a result of paving or planing is open to traffic. The HMA in the temporary wedge shall be separated from the permanent HMA by strips of heavy wrapping paper or other methods approved by the Engineer. The wrapping paper shall be removed and the joint trimmed to a slightly beveled edge for the full thickness of the course prior to resumption of paving.

The material that is cut away shall be wasted and new mix shall be laid against the cut. Rollers or tamping irons shall be used to seal the joint.

5-04.3(12)A2 Longitudinal Joints

The longitudinal joint in any one course shall be offset from the course immediately below by not more than 6 inches nor less than 2 inches. All longitudinal joints constructed in the wearing course shall be located at a lane line or an edge line of the Traveled Way. A notched wedge joint shall be constructed along all longitudinal joints in the wearing surface of new HMA unless otherwise approved by the Engineer. The notched wedge joint shall have a vertical edge of not less than the maximum aggregate size or more than $\frac{1}{2}$ of the compacted lift thickness and then taper down on a slope not steeper than 4H:1V. The sloped portion of the HMA notched wedge joint shall be uniformly compacted.

5-04.3(12)B Bridge Paving Joint Seals

Bridge Paving Joint Seals shall be in accordance with Section 5-03.

5-04.3(13) Surface Smoothness

The completed surface of all courses shall be of uniform texture, smooth, uniform as to crown and grade, and free from defects of all kinds. The completed surface of the wearing course shall not vary more than $\frac{1}{8}$ inch from the lower edge of a 10-foot straightedge placed

on the surface parallel to the centerline. The transverse slope of the completed surface of the wearing course shall vary not more than ¼ inch in 10 feet from the rate of transverse slope shown in the Plans.

When deviations in excess of the above tolerances are found that result from a high place in the HMA, the pavement surface shall be corrected by one of the following methods:

1. Removal of material from high places by grinding with an approved grinding machine, or
2. Removal and replacement of the wearing course of HMA, or
3. By other method approved by the Engineer.

Correction of defects shall be carried out until there are no deviations anywhere greater than the allowable tolerances.

Deviations in excess of the above tolerances that result from a low place in the HMA and deviations resulting from a high place where corrective action, in the opinion of the Engineer, will not produce satisfactory results will be accepted with a price adjustment. The Engineer shall deduct from monies due or that may become due to the Contractor the sum of \$500.00 for each and every section of single traffic lane 100 feet in length in which any excessive deviations described above are found.

When utility appurtenances such as manhole covers and valve boxes are located in the traveled way, the utility appurtenances shall be adjusted to the finished grade prior to paving. This requirement may be waived when requested by the Contractor, at the discretion of the Engineer or when the adjustment details provided in the project plan or specifications call for utility appurtenance adjustments after the completion of paving.

Utility appurtenance adjustment discussions will be included in the Pre-Paving and Pre-Planing Briefing (5-04.3(14)B3). Submit a written request to waive this requirement to the Engineer prior to the start of paving.

5-04.3(14) Planing Bituminous Pavement

The planing plan must be approved by the Engineer and a pre-planing meeting must be held prior to the start of any planing. See Section 5-04.3(14)B2 for information on planing submittals.

Where planing an existing pavement is specified in the Contract, the Contractor must remove existing surfacing material and to reshape the surface to remove irregularities. The finished product must be a prepared surface acceptable for receiving an HMA overlay.

Use the cold milling method for planing unless otherwise specified in the Contract. Do not use the planer on the final wearing course of new HMA.

Conduct planing operations in a manner that does not tear, break, burn, or otherwise damage the surface which is to remain. The finished planed surface must be slightly grooved or roughened and must be free from gouges, deep grooves, ridges, or other imperfections. The Contractor must repair any damage to the surface by the Contractor's planing equipment, using an Engineer approved method.

Repair or replace any metal castings and other surface improvements damaged by planing, as determined by the Engineer.

A tapered wedge cut must be planed longitudinally along curb lines sufficient to provide a minimum of 4 inches of curb reveal after placement and compaction of the final wearing course. The dimensions of the wedge must be as shown on the Drawings or as specified by the Engineer.

A tapered wedge cut must also be made at transitions to adjoining pavement surfaces (meet lines) where butt joints are shown on the Drawings. Cut butt joints in a straight line with vertical faces 2 inches or more in height, producing a smooth transition to the existing adjoining pavement.

After planing is complete, planed surfaces must be swept, cleaned, and if required by the Contract, patched and preleveled.

The Engineer may direct additional depth planing. Before performing this additional depth planing, the Contractor must conduct a hidden metal in pavement detection survey as specified in Section 5-04.3(14)A.

5-04.3(14)A Pre-Planing Metal Detection Check

Before starting planing of pavements, and before any additional depth planing required by the Engineer, the Contractor must conduct a physical survey of existing pavement to be planed with equipment that can identify hidden metal objects.

Should such metal be identified, promptly notify the Engineer.

See Section 1-07.16(1) regarding the protection of survey monumentation that may be hidden in pavement.

The Contractor is solely responsible for any damage to equipment resulting from the Contractor's failure to conduct a pre-planing metal detection survey, or from the Contractor's failure to notify the Engineer of any hidden metal that is detected.

5-04.3(14)B Paving and Planing Under Traffic**5-04.3(14)B1 General**

In addition, the requirements of Section 1-07.23 and the traffic controls required in Section 1-10, and unless the Contract specifies otherwise or the Engineer approves, the Contractor must comply with the following:

1. Intersections:
 - a. Keep intersections open to traffic at all times, except when paving or planing operations through an intersection requires closure. Such closure must be kept to the minimum time required to place and compact the HMA mixture, or plane as appropriate. For paving, schedule such closure to individual lanes or portions thereof that allows the traffic volumes and schedule of traffic volumes required in the approved traffic control plan. Schedule work so that adjacent intersections are not impacted at the same time and comply with the traffic control restrictions required by the Traffic Engineer. Each individual intersection closure or partial closure must be addressed in the traffic control plan, which must be submitted to and accepted by the Engineer, see Section 1-10.2(2).
 - b. When planing or paving and related construction must occur in an intersection, consider scheduling and sequencing such work into quarters of the intersection, or half or more of an intersection with side street detours. Be prepared to sequence the work to individual lanes or portions thereof.
 - c. Should closure of the intersection in its entirety be necessary, and no trolley service is impacted, keep such closure to the minimum time required to place and compact the HMA mixture, plane, remove asphalt, tack coat, and as needed.
 - d. Any work in an intersection requires advance warning in both signage and a number of Working Days advance notice as determined by the Engineer, to alert traffic and emergency services of the intersection closure or partial closure.
 - e. Allow new compacted HMA asphalt to cool to ambient temperature before any traffic is allowed on it. Traffic is not allowed on newly placed asphalt until approval has been obtained from the Engineer.
2. Temporary centerline marking, post-paving temporary marking, temporary stop bars, and maintaining temporary pavement marking must comply with Section 8-23.
3. Permanent pavement marking must comply with Section 8-22.

5-04.3(14)B2 Submittals - Planing Plan and HMA Paving Plan

The Contractor must submit a separate planing plan and a separate paving plan to the Engineer at least 5 Working Days in advance of each operation's activity start date. These plans must show how the moving operation and traffic control are coordinated, as they will be discussed at the pre-planing briefing and pre-paving briefing. When requested by the Engineer, the Contractor must provide each operation's traffic control plan on 24 x 36 inch or larger size Shop Drawings with a scale showing both the area of operation and sufficient detail of traffic beyond the area of operation where detour traffic may be required. The scale on the Shop Drawings is 1 inch = 20 feet, which may be changed if the Engineer agrees sufficient detail is shown.

The planing operation and the paving operation include, but are not limited to, metal detection, removal of asphalt and temporary asphalt of any kind, tack coat and drying, staging of supply trucks, paving trains, rolling, scheduling, and as may be discussed at the briefing.

When intersections will be partially or totally blocked, provide adequately sized and noticeable signage alerting traffic of closures to come, a minimum 2 Working Days in advance. The traffic control plan must show where police officers will be stationed when signalization is or may be, countermanded, and show areas where flaggers are proposed.

At a minimum, the planing and the paving plan must include:

1. A copy of the accepted traffic control plan, see Section 1-10.2(2), detailing each day's traffic control as it relates to the specific requirements of that day's planing and paving. Briefly describe the sequencing of traffic control consistent with the proposed planing and paving sequence, and scheduling of placement of temporary pavement markings and channelizing devices after each day's planing, and paving.
2. A copy of each intersection's traffic control plan.
3. Haul routes from supplier facilities, and locations of temporary parking and staging areas, including return routes. Describe the complete round trip as it relates to the sequencing of paving operations.
4. Names and locations of HMA supplier facilities to be used.
5. List of all equipment to be used for paving.
6. List of personnel and associated job classification assigned to each piece of paving equipment.

7. Description (geometric or narrative) of the scheduled sequence of planing and of paving and intended area of planing and of paving for each day's work, must include the directions of proposed planing and of proposed paving, sequence of adjacent lane paving, sequence of skipped lane paving, intersection planing and paving scheduling and sequencing, and proposed notifications and coordinations to be timely made. The plan must show HMA joints relative to the final pavement marking lane lines.
8. Names, job titles, and contact information for field, office, and plant supervisory personnel.
9. A copy of the approved Mix Designs.
10. Tonnage of HMA to be placed each day.
11. Approximate times and days for starting and ending daily operations.

5-04.3(14)B3 Pre-Paving and Pre-Planing Briefing

At least 2 Working Days before the first paving operation and the first planing operation, or as scheduled by the Engineer for future paving and planing operations to ensure the Contractor has adequately prepared for notifying and coordinating as required in the Contract, the Contractor must be prepared to discuss that day's operations as they relate to other entities and to public safety and convenience, including driveway and business access, garbage truck operations, transit operations and working around energized overhead wires, school and nursing home and hospital and other accesses, other Contractors who may be operating in the area, pedestrian and bicycle traffic, and emergency services. The Contractor, and Subcontractors that may be part of that day's operations, must meet with the Engineer and discuss the proposed operation as it relates to the submitted planing plan and paving plan, approved traffic control plan, and public convenience and safety. Such discussion includes, but is not limited to:

1. General for both the Paving and Planing:
 - a. The actual times of starting and ending daily operations.
 - b. In intersections, how to break up the intersection, and address traffic control and signalization for that operation, including use of peace officers.
 - c. The sequencing and scheduling of paving operations and of planing operations, as applicable, as it relates to traffic control, public convenience and safety, and other Contractors who may operate in the Project limits.
 - d. Notifications required of Contractor activities and coordinating with other entities and the public as necessary.

- e. Description of the sequencing of installation and types of temporary pavement markings as it relates to planning and paving.
 - f. Description of the sequencing of installation of, and the removal of, temporary pavement patch material around exposed castings and as may be needed.
 - g. Description of procedures and equipment to identify hidden metal in the pavement, such as survey monumentation, monitoring wells, streetcar rail, and castings, before planing as per Section 5-04.3(14)B2.
 - h. Description of how flaggers will be coordinated with the planing, paving, and related operations.
 - i. Description of sequencing of traffic controls for the process of rigid pavement base repairs.
 - j. Other items the Engineer deems necessary to address.
2. Paving – additional topics:
- a. When to start applying tack and coordinating with paving.
 - b. Types of equipment and numbers of each type of equipment to be used. If more pieces of equipment than personnel are proposed, describe the sequencing of the personnel operating the types of equipment. Discuss the continuance of operator personnel for each type of equipment as it relates to meeting Specification requirements.
 - c. Number of JMFs to be placed, and if more than one JMF is used, how the Contractor will ensure different JMFs are distinguished, how pavers and how MTVs are distinguished, and how pavers and MTVs are cleaned so that one JMF does not adversely influence the other JMF.
 - d. Description of contingency plans for that day's operations such as equipment breakdown, rain out, and supplier shutdown of operations.
 - e. Number of sublots to be placed, sequencing of density testing, and other sampling and testing.

5-04.3(15) Sealing Pavement Surfaces

Apply a fog seal where shown in the plans. Construct the fog seal in accordance with Section 5-02.3. Unless otherwise approved by the Engineer, apply the fog seal prior to opening to traffic.

5-04.3(16) HMA Road Approaches

Construct HMA approaches at the locations shown in the Plans or where staked by the Engineer, in accordance with Section 5-04.

5-04.4 Measurement

HMA CI. ___ PG ___, HMA for ___ CI. ___ PG ___, and Commercial HMA will be measured by the ton in accordance with Section 1-09.2, with no deduction being made for the weight of asphalt binder, mineral filler, or any other component of the mixture. If the Contractor elects to remove and replace mix as allowed by Section 5-04.3(11), the material removed will not be measured.

Roadway cores will be measured per each for the number of cores taken.

Pavement repair excavation will be measured by the square yard of surface marked prior to excavation.

Planing bituminous pavement will be measured by the square yard.

5-04.5 Payment

Payment will be made for each of the following Bid items that are included in the Proposal:

HMA CI. 1/2" PG 58H -22	Per Ton
HMA for Pavement Repair CI. 1/2" PG 58H-22	Per Ton
Pavement Repair Excavation incl. Haul	Per SY
Planing Bituminous Pavement	Per SY

The unit Contract price per ton for “HMA CI. 1/2” PG 58H-22”, and “HMA for Pavement Repair CI. 1/2” PG 58H-22” shall be full compensation for all costs, including anti-stripping additive, incurred to carry out the requirements of Section 5-04 except for those costs included in other items which are included in this Subsection and which are included in the Proposal.

5-04.5(2) Asphalt Cost Price Adjustment

New

(January 13, 2021 WSDOT GSP)

The Contracting Agency will make an Asphalt Cost Price Adjustment, either a credit or a payment, for qualifying changes in the reference cost of asphalt binder. The adjustment will be applied to partial payments made according to Section 1-09.9 for only the following:

HMA for Patch Cl. ____ PG ____
Commercial HMA

The adjustment is not a guarantee of full compensation for changes in the cost of asphalt binder. The City of Lakewood does not guarantee that asphalt binder will be available at the reference cost.

The Contracting Agency will established the asphalt binder reference cost as posted twice each month on the WSDOT website at:

<http://www.wsdot.wa.gov/Business/Construction/EscalationClauses.htm>

The reference cost will be determined using posted prices furnished by Poten & Partners, Inc. If the selected price source ceases to be available for any reason, then the Contracting Agency will select a substitute price source to establish the reference cost.

Price adjustments will be calculated one time per month. No price adjustment will be made if the Current Reference Cost is within +/-5% of the Base Cost. Reference costs for projects located in Eastern versus Western Washington shall be selected from the column in the WSDOT website table labeled “Eastern”, or “Western”, accordingly. The adjustment will be calculated as follows:

If the reference cost is greater than or equal to 105% of the base cost, then
Adjustment = (Current Reference Cost – (1.05 x Base Cost)) x (Q x 0.056).

If the reference cost is less than or equal to 95% of the base cost, then
Adjustment = (Current Reference Cost – (0.95 x Base Cost)) x (Q x 0.056).

Where:

Current Reference Cost is selected from the website table based on the “Date Effective” that immediately precedes the current month’s progress estimate end date. For work completed after all authorized working days are used, the adjustment will be based on the posted reference cost during which contract time was exhausted.

Base Cost is selected from the website table based on the “Date Effective” that immediately precedes the contract bid opening date, and shall be a constant for all monthly adjustments.

Q = total tons of all classes of HMA paid in the current month’s progress payment.

“Asphalt Cost Price Adjustment”, by calculation.

“Asphalt Cost Price Adjustment” will be calculated and paid for as described in this section. For the purpose of providing a common proposal for all bidders, the Contracting Agency has entered an amount in the proposal to become a part of the total bid by the Contractor.

Asphalt Cost Price Adjustment	Per Calculation
-------------------------------	-----------------

END OF DIVISION 5

DIVISION 7 DRAINAGE STRUCTURES, STORM SEWERS, SANITARY SEWERS, WATER MAINS, AND CONDUITS

7-05 MANHOLES, INLETS, CATCH BASINS, AND DRYWELLS

7-05.2 Materials

Supplement

Section 7-05.2 is supplemented with the following:

Frames shall be Reversible Rectangular Frames per WSDOT Standard Plan B-30.10-03.

Grates shall be Rectangular Vaned Grates per WSDOT Standard Plan B-30.30-03.

Solid Covers shall be Rectangular Solid Metal Covers per WSDOT Standard Plan B-30.20-04.

Circular Frame and Covers for catch basins shall be per WSDOT Standard Plan B-30.70-04.

Materials shall meet the following requirements of the following sections:

- Concrete 6-02
- Crushed Surfacing Top Course 9-03.9(3)
- Rubber Gaskets 9-03.12(5)
- Flexible Plastic Gaskets 9-04.4
- Metal Castings 9-05.15
- Reinforcing Steel 9-07
- Concrete Blocks 9-12.1
- Concrete Brick 9-12.2

7-05.3(1) Adjusting Manholes and Catch Basins to Grade

Supplement

Section 7-05.3(1) is supplemented with the following:

Adjustment of Sanitary Sewer Manholes shall be per Pierce County Standard Plan 1002. Pierce County will provide new rims and lids for installation at their discretion.

7-05.5 Payment

Supplement

Section 7-05.5 is supplemented with the following:

Payment will be made for the following bid items:

Adjust Manhole	Per Each
Adjust Catch Basin	Per Each

The unit contract price per each for “Adjust Manhole” and “Adjust Catch Basin” shall be full compensation for all labor, materials, tools and equipment necessary to adjust existing manholes and catch basins to final grade, in accordance with the contract documents.

**7-20 MONUMENT CASTING, VALVE, WATER METER, AND JUNCTION BOXES
ADJUSTMENT TO GRADE**

7-20.1 Description New

Section 7-20.1 is added as follows:

This section covers the adjustment to final grade of utility castings and boxes such as valve boxes, water meter boxes, monument castings, sewer cleanouts, electrical junction boxes, etc., whether or not they are located in paved areas.

Where adjustment of existing utility boxes and castings are required and the existing castings are ordered by the Engineer to be discarded or to be salvaged, the Contractor shall install new materials provided by the appropriate utility company. If new materials are not available from the serving utility, the Contractor shall provide new materials of the type specified, and payment for the new materials will be made under “Force Account” and will be in addition to payment for making the adjustment.

7-20.2 Materials New

Section 7-20.2 is added as follows:

All materials incorporated into the finished work of adjusting existing utility structures to finished grade shall conform to the requirements of Section 7-05.2, 7-19.2, 9-29.2, and any other applicable sections of the Standard Specifications.

7-20.3 Construction Requirements New

Section 7-20.3 is added as follows:

The Contractor shall adjust junction boxes, valve boxes, meter boxes, and similar structures to finished grade by utilizing the same methods of construction as specified in Section 7-05.3 of the Standard Specifications.

The Contractor shall notify the Engineer and the appropriate utility representative indicated in Section 1-07.17 of these Special Provisions a minimum of 48 hours in advance of any adjustments for inspection by a representative of the utility company. The respective utility company reserves the right to perform any adjustments with their own forces.

7-20.3(1) Adjusting Valve Box

New

Section 7-20.3(1) is added as follows:

The Contractor shall adjust existing valve boxes to the new grade as shown in the Plans or as directed by the Engineer. The Contractor shall install a valve stem extension when the operating nut on an existing valve is more than 4 feet below the new grade. The Contractor shall adjust the valve box so that the valve is operational. The Contractor shall remove all debris from the adjusted valve box.

If the Engineer determines that an existing valve box or valve box lid is unsuitable for reuse, or that a valve stem extension is required, the Contractor shall install the new materials to be provided by the appropriate utility. Valve stem extensions shall meet the requirements of Section 9-30.3(6)

7-20.4 Measurement

New

Section 7-20.4 is added as follows:

Adjustment of various existing boxes will be measured once per each location requiring adjustment regardless of the number of times the box is adjusted. In the event of adjustments by utility company forces, the adjustments will not be measured for payment on this contract.

7-20.5 Payment

New

Section 7-20.5 is added as follows:

Payment will be in accordance with Section 1-04.1 of the Standard Specifications, for the following bid items:

Adjust Valve/Junction/Meter Box	Per Each
---------------------------------	----------

The unit contract prices per each for “Adjust Valve Box/Junction Box/Meter Box” shall be full pay for all labor, materials, tools and equipment necessary to adjust the existing structures to grade, including but not limited to, excavating, backfilling, compacting, surfacing, valve stem extension, installing new valve box or cover, and restoration of adjacent areas in a manner acceptable to the Engineer, in accordance with the Contract Documents.

Adjustment to grade of new castings and structures shall be included in the bid price for the various new items.

END OF DIVISION 7

DIVISION 8 MISCELLANEOUS CONSTRUCTION

8-01 EROSION CONTROL

8-01.3 Construction Requirements

Modification

Revise the first sentence of the first paragraph of Section 8-01.3 to read as follows:

The Contractor shall prepare and submit for approval the temporary erosion and sediment control (TESC) Plan, which incorporates the Contractor's anticipated schedule, means and methods for completing the project.

8-01.3(8) Street Cleaning

Supplement

Section 8-01.3(8) is supplemented with the following:

Contractor shall be responsible at all times, for the maintenance of streets and other utilities affected by construction operations. Contractor shall clean and sweep streets at the end of each working day, and throughout the working day as deemed necessary by Engineer, to render the streets free of all mud, debris, and foreign materials.

In the event Contractor fails to conform to these requirements, Owner shall have the right to have the work done by others and the cost shall be deducted from moneys due to Contractor in accordance with Section 1-05.8 of the Standard Specifications.

8-01.3(9)D Inlet Protection

Supplement

Section 8-01.3(9)D is supplemented with the following:

At a minimum, sediment filters shall be provided on inlets to drainage structures per WSDOT Standard Plan B-30.20-04.

Inserts determined by the Engineer to be damaged and otherwise improperly functioning shall be repaired or replaced by the Contractor at no cost to the City.

8-01.4 Measurement

Modification

Section 8-01.4 is modified as follows:

No separate measurement will be made for inlet protection

8-01.5 Payment

Supplement

Section 8-01.5 is supplemented with the following:

Payment will be made for the following bid item:

Erosion Control and Water Pollution Prevention	Lump Sum
--	----------

The unit contract price per each “Erosion Control and Water Pollution Prevention” shall be full pay for all labor, materials, tools and equipment necessary to provide erosion control and water pollution prevention in accordance with the Contract Documents.

8-04 CURBS, GUTTERS, AND SPILLWAYS

8-04.3 Construction Requirements

Supplement

Section 8-04.3 is supplemented with the following:

Curbs and gutters shall be constructed in accordance with cement concrete traffic curb and gutter, WSDOT Standard Plan F-10.12-03.

The Contractor shall remove and replace any concrete curb with any chips, spalls, cracks, or hairline cracks as directed by the Engineer at no cost to the Owner.

Contractor shall take special care to construct concrete curb to line and grade as shown in the Plans. Concrete curb constructed with excessive bows, waves, or ultimately out-of-plumb shall be removed and replaced as directed by the Engineer at no cost to the Owner.

The Contractor shall be responsible for barricading, patrolling, or otherwise protecting newly placed concrete. Damaged, vandalized or unsightly concrete shall be removed and replaced at the Contractor’s expense.

8-04.5 Payment

Supplement

Section 8-04.5 is supplemented with the following:

Payment will be made for the following bid items:

Cement Concrete Traffic Curb and Gutter	Linear Foot
Cement Concrete Pedestrian Curb	Linear Foot

The unit contract price per linear foot for “Cement Concrete Traffic Curb and Gutter” and “Cement Concrete Pedestrian Curb” shall be full pay for all labor, materials, tools and equipment necessary to provide completed curb including, but not limited to special treatment around utility poles, luminaires, signal poles, vaults and junction boxes in accordance with the contract documents.

8-09 RAISED PAVEMENT MARKERS

8-09.5 Payment

Supplement

Section 8-09.5 is supplemented with the following:

Payment will be made for the following bid item:

Raised Pavement Marker Type 2	Hundred
-------------------------------	---------

8-14 CEMENT CONCRETE SIDEWALKS

8-14.2 Materials

Supplement

Section 8-14.2 is supplemented with the following:

All Detectable Warning Surface shall be yellow polymer precast units.

8-14.3 Construction Requirements

Supplement

Section 8-14.3 is supplemented with the following:

The Contractor shall remove and replace all Contractor-installed cement concrete sidewalk with any chips, spalls, cracks, or hairline cracks as directed by the Engineer at no cost to the City.

Contractor shall take special care to construct cement concrete sidewalk to line and grade as shown in the Plans. Cement concrete sidewalk constructed with excessive bows or waves shall be removed and replaced as directed by the Engineer at no cost to the Owner.

Cold joints are not permitted.

8-14.3(4) Curing

Replacement

Section 8-14.3(4) is deleted and replaced with the following:

The curing materials and procedures outlined in Section 5-05.3(13) of the Standard Specifications shall prevail, except that white pigmented curing compound shall not be used on sidewalks. The curing agent shall be applied immediately after brushing and be maintained for a period of 5 days.

The Contractor shall have readily available sufficient protective covering, such as waterproof paper or plastic membrane, to cover the pour of an entire day in the event of rain or other unsuitable weather. During the curing period, all traffic, both pedestrian and vehicular, shall be excluded. Vehicular traffic shall be excluded for such additional time as the Engineer may direct.

The Contractor shall be responsible for barricading, patrolling, or otherwise protecting the newly placed concrete to prevent damage. Damaged, vandalized, or unsightly concrete shall be removed and replaced at the expense of the Contractor. Patching, grinding or grouting repair of sidewalks will not be permitted.

8-14.3(6) Curb Ramp

New

Section 8-14.3(6) is added as follows:

At intersections where new cement concrete curb ramps are to be constructed, the Contractor shall construct curb ramps in accordance with the details in the Plans and the Standard Plans.

8-14.3(7) Sidewalk Treatment Around Utility, Luminaire and Signal Poles

New

Section 8-14.3(7) is added as follows:

The Contractor shall provide special treatment to the sidewalk area around utility poles, luminaires, and signal poles that are located within the limits of the proposed sidewalks, in accordance with the Standard Plans.

8-14.5 Payment

Supplement

Section 8-14.5 is supplemented with the following:

Payment will be made for the following bid items:

Cement Concrete Sidewalk	Square Yard
Cement Concrete Curb Ramp Type Parallel	Each
Cement Concrete Curb Ramp Type Single Direction	Each
Detectable Warning Surface	Square Foot

The unit contract price per square yard for “Cement Concrete Sidewalk” shall be full pay for all labor, materials, tools, and equipment necessary to provide completed sidewalk, including but not limited to special treatment around utility poles, luminaires, signal poles, vaults, and junction boxes in accordance with the Contract Documents.

The unit contract price per each for “Cement Concrete Curb Ramp Type ___” shall be full pay for all labor materials, tools, and equipment necessary to provide completed curb ramp, including but not limited to, forms, concrete, finishing, excavation including haul and disposal regardless of depth. Associated Pedestrian curbing shall be paid in accordance with section 8-04. Associated Detectible Warning Surface shall be paid under “Detectible Warning Surface” item.

8-21 PERMANENT SIGNING**8-21.1 Description***Supplement*

Section 8-21.1 is supplemented with the following:

Traffic and project signs specified in the Plans shall conform to the requirements of the MUTCD, WSDOT Sign Fabrication Manual and Sections 8-21 and 9-28 of the Standard Specifications.

Contractor shall supply and install traffic signs, posts, anchors, foundations, bolts and associated equipment and materials as shown in the plans.

8-21.3(5) Sign Relocation*Supplement*

Section 8-21.3(5) is supplemented with the following:

Existing traffic control and street name signs, which interfere with construction, shall be relocated or removed by the Contractor and temporarily stored in a safe place. “Stop”, “Yield”, and “One-Way” signs shall be removed or relocated only upon approval of the Engineer. Existing signs shall not be removed until the Contractor has provided temporary measures sufficient to safeguard and direct traffic after the existing signs have been removed. Preservation and maintenance of traffic control and street name signs shall be the sole responsibility of the Contractor, except as otherwise provided in the Contract Documents.

As work progresses and permits, temporarily relocated or removed traffic and street name signs shall be reset in their permanent locations by the Contractor. Signs and other traffic control devices damaged or lost by the Contractor, shall be replaced or repaired by the Contractor at no cost to the Owner. The decision of whether a sign can be repaired or shall be replaced shall be the Engineer’s and such decision shall be final and binding on the Contractor.

Existing signs not reused shall be returned to the City of Lakewood’s Operation and Maintenance Shop.

9420 Front St. S
Lakewood Operations and Maintenance Shop
Attention: Scott Williams

Telephone: (253) 267-1628

8-21.3(12) Steel Sign Posts*Replacement*

Delete Section 8-21.3(12) is and replace it with the following:

Sign posts shall be 12 gauge square 2" x 2" OD with 0.105" wall thickness, rolled carbon sheet steel, ASTM A570 Grade 50. Post shall have 7/16" diameter die-punched knockouts on 1" centers full length on four sides. Finish shall be hot dipped galvanized AASHTO M-120 with conversion coating and clear organic topcoat. Yield strength 60,000 PSI min.

Post anchor shall be 7 gauge steel heavy duty, 30" long, square 2-1/2" OD with .188 thick wall to receive 2" post with minimum of play. Anchor shall have four (4); 7/16" holes on each side, 1" from one end to center of hole. Finish shall be zinc hot dipped galvanized after fabrication. Material shall meet ASTM A500 Grade B.

Steel sign post and anchor shall be installed with 3/8-inch steel drive rivet and 12" sign cap flat blade for top of posts.

Steel sign posts shall be installed per Lakewood standard plan PS-03.

8-21.3(13) Existing Sign Maintenance

New

Section 8-21.3(13) is added as follows:

The Contractor shall maintain all existing signs within the construction limits through the duration of the project construction. This shall include, but not be limited to: sign cleaning, and resetting of damaged signs whether or not damage was a direct result of Contractor's operations.

8-21.4 Measurement

Replacement

Delete Section 8-21.4 is and replace it with the following:

Sign covering will not be measured, but will be considered as incidental to and included in the bid item "Permanent Signing".

8-21.5 Payment

Supplement

Section 8-21.5 is supplemented with the following:

Permanent Signing	Lump Sum
-------------------	----------

The lump sum bid price for "Permanent Signing" shall be full pay for all labor, materials, tools and equipment necessary to complete the work as specified, including but not limited to, providing signs and supports, foundations, temporary sign relocations, and relocation to their permanent location, sign cleaning, sign covering, and maintenance fo existing signs during construction, in accordance with the Contract Documents.

Materials, equipment, and labor required to reset/replace permanent signs that were determined to be damaged outside of the Contractor's operations shall be paid under the bid item "Minor Change".

8-22 PAVEMENT MARKING

8-22.1 Description

Supplement

Section 8-22.1 is supplemented with the following:

Pavement markings shall conform to Section 8-22 of the Standard Specifications, the Standard Plans in Appendix C, and the latest edition and amendments thereto of the Manual on Uniform Traffic Control Devices (MUTCD) as adopted by the State of Washington, and shall be constructed as shown in the Plans, except as modified herein.

The words “line” and “stripe” shall be considered interchangeable.

This work shall also include construction of durable pavement markings as shown in the Plans. The term “durable” and “plastic” shall be considered interchangeable.

This work shall also include maintaining existing pavement markings through the course of construction within the construction zone in order to provide visible channelization for the traveling public.

8-22.2 Materials

Supplement

Section 8-22.2 is supplemented with the following:

Profiled Plastic Line and Plastic Wide Lane Line shall be extruded Type D material meeting the requirements of section 9-34.3 of the Standard Specifications. “Profiled Thickness” as shown in the plans and specifications.

Plastic Stop Line, Plastic Crosswalk Line, Plastic Traffic Arrow, Plastic Traffic Letter and Plastic Bicycle Lane Symbol pavement marking materials shall be Type D material meeting the requirements of section 9-34.3 of the Standard Specifications.

Acceptance

The Contractor shall be responsible for supplying material which meets afore stated material and testing requirements. The Contractor shall supply certification that the pavement marking material meets the above specifications.

8-22.3(2) Preparation of Roadway Surfaces

Supplement

Section 8-22.3(2) is supplemented with the following:

After cleaning of areas to receive pavement markings, the areas shall pass inspection of the Engineer prior to application of the material or the primer coat.

8-22.3(5) Installation Instructions

Supplement

Section 8-22.3(5) is supplemented with the following:

The Contractor shall provide the Engineer with 2 copies of the manufacturer’s product installation procedure recommendations a minimum of 5 working days prior to the scheduled installation date.

When no manufacturer’s product installation procedure recommendations have been published, workmanship shall be governed by these Special Provisions and the Standard Specifications.

8-22.4 Measurement

Supplement

Section 8-22.4 is supplemented with the following:

Measurement of “Plastic Stop Line” will be based upon the total length of line installed.

Measurement of “Plastic Crosswalk Line” will be by the square foot of marking installed.

Measurement of “Plastic Bicycle Symbol” will be per each.

8-22.5 Payment

Supplement

Section 8-22.5 is supplemented with the following:

Payment will be made for the following bid items:

Profiled Plastic Lane Line	Per Linear Foot
Plastic Wide Lane Line	Per Linear Foot
Plastic Dotted Extension Line	Per Linear Foot
Plastic Crosswalk Line	Per Square Foot
Plastic Traffic Arrow	Per Each
Plastic Traffic Letter	Per Each
Plastic Stop Line	Per Linear Foot
Plastic Bicycle Lane Symbol	Per Each

The unit contract prices for the above bid items shall be full pay for all labor, materials, tools and equipment necessary to provide the various pavement markings, including but not limited to, refreshing and maintaining existing pavement markings through the course of construction, in accordance with the contract documents.

END OF DIVISION 8

DIVISION 9 MATERIALS

9-03 AGGREGATES

9-03.8(2) HMA Test Requirements

Supplement

Section 9-03.8(2) is supplemented with the following:

The number of ESAL's for the design and acceptance of HMA shall be 2.9 million.

9-03.8(7) HMA Tolerance and Adjustments

Modification

Section 9-03.8(7) is modified as follows:

Delete Item 1 and replace it with the following:

1. **Job Mix Formula Tolerances.** After the JMF is determined as required in 5-04.3(7)A of the Standard Specifications, the constituents of the HMA mixture at the time of acceptance shall conform to the following tolerances:

Aggregate, percent passing	Non-Statistical Evaluation
1", ¾", ½", and 3/8" sieves	±6%
U.S. No. 4 sieve	±6%
U.S. No. 8 sieve	±6%
U.S. No. 200 sieve	±2.0%
Asphalt Binder	±0.5%

These tolerance limits constitute the allowable limits as described in Section 1-06.2 of the Standard Specifications. The tolerance limit for aggregate shall not exceed the limits of the control points section, except the tolerance limits for sieves designated as 100% passing will be 99-100. The tolerance limits on sieves shall only apply to sieves with control points.

END OF DIVISION 9

Standard Plans

New

(February 26, 2024, WSDOT GSP)

The State of Washington Standard Plans for Road, Bridge and Municipal Construction M21-01, effective October 23, 2023, is made a part of this contract.

The Standard Plans are revised as follows:

A-10.30

RISER RING detail (Including SECTION view and RISER RING DIMENSIONS table): The RISER RING detail is deleted from the plan.

INSTALLATION detail, SECTION A: The "1/4"" callout is revised to read "+/- 1/4" (SEE CONTRACT ~ Note: The + 1/4" installation is shown in the Section A view)"

A-40.20

Sheet 1, NOTES 1, 2, 3, and 4 are replaced with the following:

1. Use the 1/2 inch joint details for bridges with expansion length less than 100 feet and for bridges with L type abutments. Use the 1 inch joint details for other applications.
2. Use detail 5, 6, 7 on steel trusses and timber bridges with concrete bridge deck panels.
3. For details 1, 2, 3, and 4, the item "HMA Joint Seal at Bridge End" shall be used for payment. For details 5 and 6, the item "HMA Joint Seal at Bridge Deck Panel Joint" shall be used for payment. For detail 7, the item "Clean and Seal Bridge Deck Panel Joint" shall be used for payment.

Sheet 2, Detail 8 reference to "6-09.3(6)" is revised to read "6-21.3(7)".

A-60.40

Note 2 reference to "6-09.3(6)" is revised to read "6-21.3(7)".

B-90.40

Valve Detail – DELETED

C-60.10

Sheet 1 of 2, Side view, add new callout pointing to the outer edges of the 3" x 12" lifting slots at bottom of barrier. New callout reads "PERMISSIBLE 3/4" CHAMFER."

Sheet 1 of 2, Side view, add 2-inch diameter lifting holes centered 32" from each end of the barrier and 15" from the top face (2 lifting holes total). Add new callout pointing to the new lifting holes. New callout reads "PERMISSIBLE 2" DIAM. LIFTING HOLE"

C-85.11

On Section B, the callout "3" EXPANDED POLYSTYRENE AROUND COLUMN (TYP.);" is revised to read "3" EXPANDED POLYSTYRENE OR POLYETHYLENE FOAM AROUND COLUMN (TYP.);"

D-3.10

Sheet 1, Typical Section, callout – “FOR WALLS WITH SINGLE SLOPE TRAFFIC BARRIER. USE THE DETAILS ABOVE THE MATCH LINE ON STANDARD PLAN D-3.15” is revised to read; “FOR WALLS WITH SINGLE SLOPE TRAFFIC BARRIER, SEE CONTRACT PLANS”

Sheet 1, Typical Section, callout – “FOR WALLS WITH F-SHAPE TRAFFIC BARRIER. USE THE DETAILS ABOVE THE MATCH LINE ON STANDARD PLAN D-3.16” is revised to read; “FOR WALLS WITH F-SHAPE TRAFFIC BARRIER, SEE CONTRACT PLANS”

D-3.11

Sheet 1, Typical Section, callout – ““B” BRIDGE APPROACH SLAB (SEE BRIDGE PLANS) OR PERMANENT GEOSYNTHETIC WALL BARRIER ~ SEE STANDARD PLANS D-3.15 OR D-3.16” is revised to read; “B” BRIDGE APPROACH SLAB OR MOMENT SLAB (SEE CONTRACT PLANS)

Sheet 1, Typical Section, callout – “TYPICAL BARRIER ON BRIDGE APPROACH SLAB (SEE BRIDGE PLANS) OR PERMANENT GEOSYNTHETIC WALL BARRIER ~ SEE STANDARD PLANS D-3.15 OR D-3.16” is revised to read; “TYPICAL BARRIER ON BRIDGE APPROACH SLAB OR MOMENT SLAB (SEE CONTRACT PLANS)

D-10.10

Wall Type 1 may be used if no traffic barrier is attached on top of the wall. Walls with traffic barriers attached on top of the wall are considered non-standard and shall be designed in accordance with the current WSDOT Bridge Design Manual (BDM) and the revisions stated in the 11/3/15 Bridge Design memorandum.

D-10.15

Wall Type 2 may be used if no traffic barrier is attached on top of the wall. Walls with traffic barriers attached on top of the wall are considered non-standard and shall be designed in accordance with the current WSDOT BDM and the revisions stated in the 11/3/15 Bridge Design memorandum.

D-10.30

Wall Type 5 may be used in all cases.

D-10.35

Wall Type 6 may be used in all cases.

D-10.40

Wall Type 7 may be used if no traffic barrier is attached on top of the wall. Walls with traffic barriers attached on top of the wall are considered non-standard and shall be designed in accordance with the current WSDOT BDM and the revisions stated in the 11/3/15 Bridge Design memorandum.

D-10.45

Wall Type 8 may be used if no traffic barrier is attached on top of the wall. Walls with traffic barriers attached on top of the wall are considered non-standard and shall be designed in accordance with the current WSDOT BDM and the revisions stated in the revisions stated in the 11/3/15 Bridge Design memorandum.

F-10.18

Note 2, "Region Traffic engineer approval is needed to install a truck apron lower than 3". - DELETED

J-10.10

Sheet 4 of 6, "Foundation Size Reference Table", PAD WIDTH column, Type 33xD=6' – 3" is revised to read: 7' – 3". Type 342LX / NEMA P44=5' – 10" is revised to read: 6' – 10"

Sheet 5 of 6, Plan View, "FOR EXAMPLE PAD SHOWN HERE:", "first bullet" item, "-SPACE BETWEEN TYPE B MOD. CABINET AND 33x CABINET IS 6" (IN)" IS REVISED TO READ: "SPACE BETWEEN TYPE B MOD. CABINET (BACK OF ALL CHANNEL STEEL) AND 33x CABINET IS 6" (IN) (CHANNEL STEEL ADDS ABOUT 5" (IN))"

J-10.16

Key Note 1, Standard Plan J-10.30 revised to Standard Plan J-10.14

J-10.17

Key Note 1, Standard Plan J-10.30 revised to Standard Plan J-10.14

J-10.18

Key Note 1, Standard Plan J-10.30 revised to Standard Plan J-10.14

J-20.26

Add Note 1, "1. One accessible pedestrian pushbutton station per pedestrian pushbutton post."

J-20.16

View A, callout, was – LOCK NIPPLE, is revised to read; CHASE NIPPLE

J-21.10

Sheet 1 of 2, Elevation View, Round Concrete Foundation Detail, callout – "ANCHOR BOLTS ~ ¾" (IN) x 30" (IN) FULL THREAD ~ THREE REQ'D. PER ASSEMBLY" IS REVISED TO READ: "ANCHOR BOLTS ~ ¾" (IN) x 30" (IN) FULL THREAD ~ FOUR REQ'D. PER ASSEMBLY"

Sheet 1 of 2, Elevation view (Round), add dimension depicting the distance from the top of the foundation to find 2 #4 reinforcing bar shown, to read; 3" CLR. Delete "(TYP.)" from the 2 ½" CLR. dimension, depicting the distance from the bottom of the foundation to find 2 # 4 reinf. Bar.

Sheet 1 of 2, Elevation view (Square), add dimension depicting the distance from the top of the foundation to find 1 #4 reinforcing bar shown, to read; 3" CLR. Delete "(TYP.)" from the 2 ½" CLR. dimension, depicting the distance from the bottom of the foundation to find 1 # 4 reinf. Bar.

Sheet 2 of 2, Elevation view (Round), add dimension depicting the distance from the top of the foundation to find 2 #4 reinforcing bar shown, to read; 3" CLR. Delete "(TYP.)" from the 2 ½" CLR. dimension, depicting the distance from the bottom of the foundation to find 2 # 4 reinf. Bar.

Sheet 2 of 2, Elevation view (Square), add dimension depicting the distance from the top of the foundation to find 1 #4 reinforcing bar shown, to read; 3" CLR. Delete "(TYP.)" from the 2 ½" CLR. dimension, depicting the distance from the bottom of the foundation to find 1 # 4 reinf. Bar.

Detail F, callout, "Heavy Hex Clamping Bolt (TYP.) ~ 3/4" (IN) Diam. Torque Clamping Bolts (see Note 3)" is revised to read; "Heavy Hex Clamping Bolt (TYP.) ~ 3/4" (IN) Diam. Torque Clamping Bolts (see Note 1)"

Detail F, callout, "3/4" (IN) x 2' – 6" Anchor Bolt (TYP.) ~ Four Required (See Note 4)" is revised to read; "3/4" (IN) x 2' – 6" Anchor Bolt (TYP.) ~ Three Required (See Note 2)"

J-21.15

Partial View, callout, was – LOCK NIPPLE ~ 1 1/2" DIAM., is revised to read; CHASE NIPPLE ~ 1 1/2" (IN) DIAM.

J-21.16

Detail A, callout, was – LOCKNIPPLE, is revised to read; CHASE NIPPLE

J-22.15

Ramp Meter Signal Standard, elevation, dimension 4' - 6" is revised to read; 6'-0"

(2x) Detail A, callout, was – LOCK NIPPLE ~ 1 1/2" DIAM. is revised to read; CHASE NIPPLE ~ 1 1/2" (IN) DIAM.

J-40.10

Sheet 2 of 2, Detail F, callout, "12 – 13 x 1 1/2" S.S. PENTA HEAD BOLT AND 12" S. S. FLAT WASHER" is revised to read; "12 – 13 x 1 1/2" S.S. PENTA HEAD BOLT AND 1/2" (IN) S. S. FLAT WASHER"

J-40.36

Note 1, second sentence; "Finish shall be # 2B for backbox and # 4 for the cover." Is revised to read; "Finish shall be # 2B for barrier box and HRAP (Hot Rolled Annealed and Pickled) for the cover.

J-40.37

Note 1, second sentence; "Finish shall be # 2B for backbox and # 4 for the cover." Is revised to read; "Finish shall be # 2B for barrier box and HRAP (Hot Rolled Annealed and Pickled) for the cover.

J-75.20

Key Notes, note 16, second bullet point, was: "1/2" (IN) x 0.45" (IN) Stainless Steel Bands", add the following to the end of the note: "Alternate: Stainless steel cable with stainless steel ends, nuts, bolts, and washers may be used in place of stainless steel bands and associated hardware."

J-75.55

Notes, Note A1, Revise reference, was – G-90.29, should be – G-90.20.

L-5.10

Sheet 1, General Note 8, third sentence – was; "For traffic barrier having no deflection distance, the fence shall be placed a minimum horizontal distance of 3' – 6' as measured form the top front face of the barrier." Is revised to read; "For traffic barrier having no deflection distance, the fence shall be placed a minimum horizontal distance of 2' – 6" as measured form the top front face of the barrier."

Sheet 2, Reinforcing Steel Bending Diagram, (mark) B detail, callout – “128 deg.” is revised to read: “123 deg.”, callout – “51 deg.” is revised to read: “57 deg.”

M-40.10

Guide Post Type ~ Reflective Sheeting Applications Table, remove reference - “(SEE NOTE 5)”

The following are the Standard Plan numbers applicable at the time this project was advertised. The date shown with each plan number is the publication approval date shown in the lower right-hand corner of that plan. Standard Plans showing different dates shall not be used in this contract.

A-10.10-00 8/7/07	A-30.35-00.....10/12/07	A-50.10-01.....8/17/21
A-10.20-00 10/5/07	A-40.00-01 7/6/22	A-50.40-01.....8/17/21
A-10.30-00 10/5/07	A-40.10-04 7/31/19	A-60.10-03.....12/23/14
A-20.10-00 8/31/07	A-40.15-00 8/11/09	A-60.20-03.....12/23/14
A-30.10-00 11/8/07	A-40.20-04 1/18/17	A-60.30-01.....6/28/18
A-30.30-01 6/16/11	A-40.50-03 9/12/23	A-60.40-00.....8/31/07
B-5.20-03 9/9/20	B-30.50-03.....2/27/18	B-75.20-03 8/17/21
B-5.40-02 1/26/17	B-30.60-00.....9/9/20	B-75.50-02 3/15/22
B-5.60-02 1/26/17	B-30.40-03.....2/27/18	B-70.60-01 1/26/17
B-10.20-03 8/23/23	B-30.70-04.....2/27/18	B-75.60-00 6/8/06
B-10.40-02 8/17/21	B-30.80-01.....2/27/18	B-80.20-00 6/8/06
B-10.70-03 8/23/23	B-30.90-02.....1/26/17	B-80.40-00 6/1/06
B-15.20-01 2/7/12	B-35.20-00.....6/8/06	B-85.10-01 6/10/08
B-15.40-01 2/7/12	B-35.40-01.....8/23/23	B-85.20-00 6/1/06
B-15.60-02 1/26/17	B-40.20-00.....6/1/06	B-85.30-00 6/1/06
B-20.20-02 3/16/12	B-40.40-02.....1/26/17	B-85.40-00 6/8/06
B-20.40-04 2/27/18	B-45.20-01.....7/11/17	B-85.50-01 6/10/08
B-20.60-03 3/15/12	B-45.40-01.....7/21/17	B-90.10-00
	6/8/06
B-25.20-02 2/27/18	B-50.20-00.....6/1/06	B-90.20-00 6/8/06
B-25.60-03 8/23/23	B-55.20-03.....8/17/21	B-90.30-00 6/8/06
B-30.05-00 9/9/20	B-60.20-02.....9/9/20	B-90.40-01 1/26/17
B-30.10-03 2/27/18	B-60.40-01.....2/27/18	B-90.50-00 6/8/06
B-30.15-00 2/27/18	B-65.20-01.....4/26/12	B-95.20-02 8/17/21
B-30.20-04 2/27/18	B-65.40-00.....6/1/06	B-95.40-01 6/28/18
B-30.30-03 2/27/18	B-70.20-01.....3/15/22	
C-1..... 9/8/22	C-22.40-10 10/16/23	C-60.70-01 9/8/22
C-1b..... 10/12/23	C-22.45-06 9/8/22	C-60.80-01 9/8/22
C-1d..... 10/31/03	C-23.70-01 10/16/23	C-70.15-00 8/17/21
C-2c..... 8/12/19	C-24.10-04..... 10/16/23	C-70.10-04 10/16/23
C-4f..... 8/12/19	C-24.15-00 3/15/22	C-75.10-02 9/16/20
C-6a..... 9/8/22	C-25.20-07 8/20/21	C-75.20-03 8/20/21
C-7..... 9/8/22	C-25.22-06 8/20/21	C-75.30-03 8/20/21
C-7a..... 9/8/22	C-25.26-05 8/20/21	C-80.10-03 10/16/23
C-20.10-09..... 10/12/23	C-25.30-01 8/20/21	C-80.20-01 6/11/14

C-20.14-05..... 9/8/22	C-25.80-058/12/19	C-80.30-02 8/20/21
C-20.15-03..... 10/12/23	C-60.10-03 10/16/23	C-80.40-01 6/11/14
C-20.18-04..... 9/8/22	C-60.15-00 8/17/21	C-85.10-00 4/8/12
C-20.40-10..... 10/12/23	C-60.20-01 9/8/22	C-85.11-01 9/16/20
C-20.41-04..... 8/22/22	C-60.30-01 8/17/21	C-85.15-03 10/17/23
C-20.42-06..... 10/12/23	C-60.40-00 8/17/21	C-85-18-03 9/8/22
C-20.43-00..... 8/22/22	C-60.45-00 8/17/21	C-81.10-00 9/12/23
C-20.45.03 9/8/22	C-60.50-00 8/17/21	C-81.15-00 9/12/23
C-22.16-08..... 10/17/23	C-60.60-00 8/17/21	
D-2.36-03..... 6/11/14	D-3.11-036/11/14	D-10.25-01 8/7/19
D-2.46-02..... 8/13/21	D-4 12/11/98	D-10.30-00 7/8/08
D-2.84-00..... 11/10/05	D-6 6/19/98	D-10.35-00 7/8/08
D-2.92-01 4/26/22	D-10.10-01 12/2/08	D-10.40-01 12/2/08
D-3.09-00..... 5/17/12	D-10.15-01 12/2/08	D-10.45-01 12/2/08
D-3.10-01..... 5/29/13	D-10.20-01 8/7/19	D-20.10-00 10/9/23
E-1 2/21/07	E-4..... 8/27/03	E-20.10-00 9/12/23
E-2..... 5/29/98	E-4a..... 8/27/03	E-20.20-00 10/4/23
F-10.12-04 9/24/20	F-10.62-02.....4/22/14	F-40.15-04.....9/25/20
F-10.16-00 12/20/06	F-10.64-03.....4/22/14	F-40.16-03..... 6/29/16
F-10.18-03 3/28/22	F-30.10-04.....9/25/20	F-45.10-04..... 10/16/23
F-10.40-04 9/24/20	F-40.12-03.....6/29/16	F-80.10-04..... 7/15/16
F-10.42-00 1/23/07	F-40.14-03..... 6/29/16	
G-10.10-00..... 9/20/07	G-24.50-05 8/7/19	G-90.10-03 7/11/17
G-20.10-03..... 8/20/21	G-24.60-05 6/28/18	G-90.20-05 7/11/17
G-22.10-04..... 6/28/18	G-25.10-05 9/16/20	G-90.30-04 7/11/17
G-24.10-00..... 11/8/07	G-26.10-00 7/31/19	G-95.10-02 6/28/18
G-24.20-01..... 2/7/12	G-30.10-04 6/23/15	G-95.20-03 6/28/18
G-24.30-02..... 6/28/18	G-50.10-03 6/28/18	G-95.30-03 6/28/18
G-24.40-07..... 6/28/18		
H-10.10-00..... 7/3/08	H-32.10-00 9/20/07	H-70.10-02 8/17/21
H-10.15-00..... 7/3/08	H-60.10-01 7/3/08	H-70.20-02 8/17/21
H-30.10-00..... 10/12/07	H-60.20-01 7/3/08	
I-10.10-01 8/11/09	I-30.20-00 9/20/07	I-40.20-00 9/20/07
I-30.10-02 3/22/13	I-30.30-02 6/12/19	I-50.20-02 7/6/22
I-30.15-02 3/22/13	I-30.40-02 6/12/19	I-60.10-01 6/10/13
I-30.16-01 7/11/19	I-30.60-02 6/12/19	I-60.20-01 6/10/13
I-30.17-01 6/12/19	I-40.10-00 9/20/07	I-80.10-02 7/15/16
J-05.50-00..... 8/30/22	J-26.20-01 6/28/18	J-50.10-01 7/31/19
J-10..... 7/18/97	J-27.10-01 7/21/16	J-50.11-02 7/31/19
J-10.10-04..... 9/16/20	J-27.15-00 3/15/12	J-50.12-02 8/7/19
J-10.12-00..... 9/16/20	J-28.01-00 8/30/22	J-50.13-01 8/30/22
J-10.14-00..... 9/16/20	J-28.10-02 8/7/19	J-50.15-01 7/21/17

J-10.15-01.....	6/11/14	J-28.22-00.....	8/07/07	J-50.16-01.....	3/22/13
J-10.16-02.....	8/18/21	J-28.24-02.....	9/16/20	J-50.18-00.....	8/7/19
J-10.17-02.....	8/18/21	J-28.26-01.....	12/02/08	J-50.19-00.....	8/7/19
J-10.18-02.....	8/18/21	J-28.30-03.....	6/11/14	J-50.20-00.....	6/3/11
J-10.20-04.....	8/18/21	J-28.40-02.....	6/11/14	J-50.25-00.....	6/3/11
J-10.21-02.....	8/18/21	J-28.42-01.....	6/11/14	J-50.30-00.....	6/3/11
J-10.22-03.....	10/4/23	J-28.43-01.....	6/28/18	J-60.05-01.....	7/21/16
J-10.25-00.....	7/11/17	J-28.45-03.....	7/21/16	J-60.11-00.....	5/20/13
J-10.26-00.....	8/30/22	J-28.50-03.....	7/21/16	J-60.12-00.....	5/20/13
J-12.15-00.....	6/28/18	J-28.60-03.....	8/27/21	J-60.13-00.....	6/16/10
J-12.16-00.....	6/28/18	J-28.70-04.....	8/30/22	J-60.14-01.....	7/31/19
J-15.10-01.....	6/11/14	J-29.10-02.....	8/26/22	J-75.10-02.....	7/10/15
J-15.15-02.....	7/10/15	J-29.15-01.....	7/21/16	J-75.20-01.....	7/10/15
J-20.01-00.....	8/30/22	J-29.16-02.....	7/21/16	J-75.30-02.....	7/10/15
J-20.10-05.....	10/4/23	J-30.10-01.....	8/26/22	J-75.50-00.....	8/30/22
J-20.11-03.....	7/31/19	J-40.01-00.....	8/30/22	J-75.55-00.....	8/30/22
J-20.15-03.....	6/30/14	J-40.05-00.....	7/21/16	J-80.05-00.....	8/30/22
J-20.16-02.....	6/30/14	J-40.10-04.....	4/28/16	J-80.10-01.....	8/18/21
J-20.20-02.....	5/20/13	J-40.20-03.....	4/28/16	J-80.12-00.....	8/18/21
J-20.26-01.....	7/12/12	J-40.30-04.....	4/28/16	J-80.15-00.....	6/28/18
J-21.10-04.....	6/30/14	J-40.35-01.....	5/29/13	J-81.10-02.....	8/18/21
J-21.15-01.....	6/10/13	J-40.36-02.....	7/21/17	J-81.12-00.....	9/3/21
J-21.16-01.....	6/10/13	J-40.37-02.....	7/21/17	J-84.05-00.....	8/30/22
J-21.17-01.....	6/10/13	J-40.38-01.....	5/20/13	J-86.10-00.....	6/28/18
J-21.20-01.....	6/10/13	J-40.39-00.....	5/20/13	J-90.10-03.....	6/28/18
J-22.15-02.....	7/10/15	J-40.40-02.....	7/31/19	J-90.20-03.....	6/28/18
J-22.16-03.....	7/10/15	J-45.36-00.....	7/21/17	J-90.21-02.....	6/28/18
J-26.10-03.....	7/21/16	J-50.05-00.....	7/21/17	J-90.50-00.....	6/28/18
J-26.15-01.....	5/17/12				
K-70.20-01.....	6/1/16	K-80.32-00.....	8/17/21	K-80.35-01.....	9/16/20
K-80.10-02.....	9/25/20	K-80.34-00.....	8/17/21	K-80.37-01.....	9/16/20
L-5.10-01.....	7/17/23	L-20.10-03.....	7/14/15	L-40.20-02.....	6/21/12
L-5.15-00.....	9/19/22	L-30.10-02.....	6/11/14	L-70.10-01.....	5/21/08
L-10.10-02.....	6/21/12	L-40.15-01.....	6/16/11	L-70.20-01.....	5/21/08
M-1.20-04.....	9/25/20	M-9.60-00.....	2/10/09	M-24.66-00.....	7/11/17
M-1.40-03.....	9/25/20	M-11.10-04.....	8/2/22	M-40.10-04.....	10/17/23
M-1.60-03.....	9/25/20	M-12.10-03.....	8/2/22	M-40.20-00.....	10/12/07
M-1.80-03.....	6/3/11	M-15.10-02.....	7/17/23	M-40.30-01.....	7/11/17
M-2.20-03.....	7/10/15	M-17.10-02.....	7/3/08	M-40.40-00.....	9/20/07
M-2.21-00.....	7/10/15	M-20.10-04.....	8/2/22	M-40.50-00.....	9/20/07
M-3.10-04.....	9/25/20	M-20.20-02.....	4/20/15	M-40.60-00.....	9/20/07
M-3.20-04.....	8/2/22	M-20.30-04.....	2/29/16	M-60.10-01.....	6/3/11
M-3.30-04.....	9/25/20	M-20.40-03.....	6/24/14	M-60.20-03.....	8/17/21
M-3.40-04.....	9/25/20	M-20.50-02.....	6/3/11	M-65.10-03.....	8/17/21
M-3.50-03.....	9/25/20	M-24.20-02.....	4/20/15	M-80.10-01.....	6/3/11
M-5.10-03.....	9/25/20	M-24.40-02.....	4/20/15	M-80.20-00.....	6/10/08

M-7.50-01 1/30/07
M-9.50-02 6/24/14

M-24.60-04 6/24/14
M-24.65-00 7/11/17

M-80.30-00 6/10/08

Appendix A
State Prevailing Wage Rates

Washington State Department of Labor and Industries
Policy Statement
(Regarding the Production of "Standard" or "Non-standard" Items)

Below is the department's (State L&I's) list of criteria to be used in determining whether a prefabricated item is "standard" or "non-standard". For items not appearing on WSDOT's predetermined list, these criteria shall be used by the Contractor (and the Contractor's subcontractors, agents to subcontractors, suppliers, manufacturers, and fabricators) to determine coverage under RCW 39.12. The production, in the State of Washington, of non-standard items is covered by RCW 39.12, and the production of standard items is not. The production of any item outside the State of Washington is not covered by RCW 39.12.

1. Is the item fabricated for a public works project? If not, it is not subject to RCW 39.12. If it is, go to question 2.
2. Is the item fabricated on the public works jobsite? If it is, the work is covered under RCW 39.12. If not, go to question 3.
3. Is the item fabricated in an assembly/fabrication plant set up for, and dedicated primarily to, the public works project? If it is, the work is covered by RCW 39.12. If not, go to question 4.
4. Does the item require any assembly, cutting, modification or other fabrication by the supplier? If not, the work is not covered by RCW 39.12. If yes, go to question 5.
5. Is the prefabricated item intended for the public works project typically an inventory item which could reasonably be sold on the general market? If not, the work is covered by RCW 39.12. If yes, go to question 6.
6. Does the specific prefabricated item, generally defined as standard, have any unusual characteristics such as shape, type of material, strength requirements, finish, etc? If yes, the work is covered under RCW 39.12.

Any firm with questions regarding the policy, WSDOT's Predetermined List, or for determinations of covered and non-covered workers shall be directed to State L&I at (360) 902-5330.

**WSDOT's
Predetermined List for
Suppliers - Manufactures - Fabricator**

Below is a list of potentially prefabricated items, originally furnished by WSDOT to Washington State Department of Labor and Industries, that may be considered non-standard and therefore covered by the prevailing wage law, RCW 39.12. Items marked with an X in the "YES" column should be considered to be non-standard and therefore covered by RCW 39.12. Items marked with an X in the "NO" column should be considered to be standard and therefore not covered. Of course, exceptions to this general list may occur, and in that case shall be evaluated according to the criteria described in State and L&I's policy statement.

ITEM DESCRIPTION	YES	NO
1. Metal rectangular frames, solid metal covers, herringbone grates, and bi-directional vaned grates for Catch Basin Types 1, 1L, 1P, and 2 and Concrete Inlets. See Std. Plans		X
2. Metal circular frames (rings) and covers, circular grates, and prefabricated ladders for Manhole Types 1, 2, and 3, Drywell Types 1, 2, and 3 and Catch Basin Type 2. See Std. Plans		X
3. Prefabricated steel grate supports and welded grates, metal frames and dual vaned grates, and Type 1, 2, and 3 structural tubing grates for Drop Inlets. See Std. Plans.		X
4. Concrete Pipe - Plain Concrete pipe and reinforced concrete pipe Class 2 to 5 sizes smaller than 60 inch diameter.		X
5. Concrete Pipe - Plain Concrete pipe and reinforced concrete pipe Class 2 to 5 sizes larger than 60 inch diameter.		X
6. Corrugated Steel Pipe - Steel lock seam corrugated pipe for culverts and storm sewers, sizes 30 inch to 120 inches in diameter. May also be treated, 1 thru 5.		X
7. Corrugated Aluminum Pipe - Aluminum lock seam corrugated pipe for culverts and storm sewers, sizes 30 inch to 120 inches in diameter. May also be treated, #5.		X

ITEM DESCRIPTION	YES	NO
8. Anchor Bolts & Nuts - Anchor Bolts and Nuts, for mounting sign structures, luminaries and other items, shall be made from commercial bolt stock. See Contract Plans and Std. Plans for size and material type.		X
9. Aluminum Pedestrian Handrail - Pedestrian handrail conforming to the type and material specifications set forth in the contract plans. Welding of aluminum shall be in accordance with Section 9-28.14(3).	X	
10. Major Structural Steel Fabrication - Fabrication of major steel items such as trusses, beams, girders, etc., for bridges.	X	
11. Minor Structural Steel Fabrication - Fabrication of minor steel Items such as special hangers, brackets, access doors for structures, access ladders for irrigation boxes, bridge expansion joint systems, etc., involving welding, cutting, punching and/or boring of holes. See Contact Plans for item description and shop drawings.	X	
12. Aluminum Bridge Railing Type BP - Metal bridge railing conforming to the type and material specifications set forth in the Contract Plans. Welding of aluminum shall be in accordance with Section 9-28.14(3).		X
13. Concrete Piling--Precast-Prestressed concrete piling for use as 55 and 70 ton concrete piling. Concrete to conform to Section 9-19.1 of Std. Spec..	X	
14. Precast Manhole Types 1, 2, and 3 with cones, adjustment sections and flat top slabs. See Std. Plans.		X
15. Precast Drywell Types 1, 2, and with cones and adjustment Sections. See Std. Plans.		X
16. Precast Catch Basin - Catch Basin type 1, 1L, 1P, and 2 With adjustment sections. See Std. Plans.		X

ITEM DESCRIPTION	YES	NO
17. Precast Concrete Inlet - with adjustment sections, See Std. Plans		X
18. Precast Drop Inlet Type 1 and 2 with metal grate supports. See Std. Plans.		X
19. Precast Grate Inlet Type 2 with extension and top units. See Std. Plans		X
20. Metal frames, vaned grates, and hoods for Combination Inlets. See Std. Plans		X
21. Precast Concrete Utility Vaults - Precast Concrete utility vaults of various sizes. Used for in ground storage of utility facilities and controls. See Contract Plans for size and construction requirements. Shop drawings are to be provided for approval prior to casting		X
22. Vault Risers - For use with Valve Vaults and Utilities X Vaults.		X
23. Valve Vault - For use with underground utilities. See Contract Plans for details.		X
24. Precast Concrete Barrier - Precast Concrete Barrier for use as new barrier or may also be used as Temporary Concrete Barrier. Only new state approved barrier may be used as permanent barrier.		X
25. Reinforced Earth Wall Panels – Reinforced Earth Wall Panels in size and shape as shown in the Plans. Fabrication plant has annual approval for methods and materials to be used. See Shop Drawing. Fabrication at other locations may be approved, after facilities inspection, contact HQ. Lab.	X	
26. Precast Concrete Walls - Precast Concrete Walls - tilt-up wall panel in size and shape as shown in Plans. Fabrication plant has annual approval for methods and materials to be used	X	

ITEM DESCRIPTION	YES	NO
27. Precast Railroad Crossings - Concrete Crossing Structure Slabs.	X	
28. 12, 18 and 26 inch Standard Precast Prestressed Girder – Standard Precast Prestressed Girder for use in structures. Fabricator plant has annual approval of methods and materials to be used. Shop Drawing to be provided for approval prior to casting girders. See Std. Spec. Section 6-02.3(25)A	X	
29. Prestressed Concrete Girder Series 4-14 - Prestressed Concrete Girders for use in structures. Fabricator plant has annual approval of methods and materials to be used. Shop Drawing to be provided for approval prior to casting girders. See Std. Spec. Section 6-02.3(25)A	X	
30. Prestressed Tri-Beam Girder - Prestressed Tri-Beam Girders for use in structures. Fabricator plant has annual approval of methods and materials to be used. Shop Drawing to be provided for approval prior to casting girders. See Std. Spec. Section 6-02.3(25)A	X	
31. Prestressed Precast Hollow-Core Slab – Precast Prestressed Hollow-core slab for use in structures. Fabricator plant has annual approval of methods and materials to be used. Shop Drawing to be provided for approval prior to casting girders. See Std. Spec. Section 6-02.3(25)A.	X	
32. Prestressed-Bulb Tee Girder - Bulb Tee Prestressed Girder for use in structures. Fabricator plant has annual approval of methods and materials to be used. Shop Drawing to be provided for approval prior to casting girders. See Std. Spec. Section 6-02.3(25)A	X	
33. Monument Case and Cover See Std. Plan.		X

ITEM DESCRIPTION	YES	NO
34. Cantilever Sign Structure - Cantilever Sign Structure fabricated from steel tubing meeting AASHTO-M-183. See Std. Plans, and Contract Plans for details. The steel structure shall be galvanized after fabrication in accordance with AASHTO-M-111.	X	
35. Mono-tube Sign Structures - Mono-tube Sign Bridge fabricated to details shown in the Plans. Shop drawings for approval are required prior to fabrication.	X	
36. Steel Sign Bridges - Steel Sign Bridges fabricated from steel tubing meeting AASHTO-M-138 for Aluminum Alloys. See Std. Plans, and Contract Plans for details. The steel structure shall be galvanized after fabrication in accordance with AASHTO-M-111.	X	
37. Steel Sign Post - Fabricated Steel Sign Posts as detailed in Std Plans. Shop drawings for approval are to be provided prior to fabrication		X
38. Light Standard-Prestressed - Spun, prestressed, hollow concrete poles.	X	
39. Light Standards - Lighting Standards for use on highway illumination systems, poles to be fabricated to conform with methods and materials as specified on Std. Plans. See Special Provisions for pre-approved drawings.	X	
40. Traffic Signal Standards - Traffic Signal Standards for use on highway and/or street signal systems. Standards to be fabricated to conform with methods and material as specified on Std. Plans. See Special Provisions for pre-approved drawings	X	
41. Precast Concrete Sloped Mountable Curb (Single and DualFaced) See Std. Plans.		X

ITEM DESCRIPTION	YES	NO
42. Traffic Signs - Prior to approval of a Fabricator of Traffic Signs, the sources of the following materials must be submitted and approved for reflective sheeting, legend material, and aluminum sheeting. NOTE: *** Fabrication inspection required. Only signs tagged "Fabrication Approved" by WSDOT Sign Fabrication Inspector to be installed	X	X
	Custom Message	Std Signing Message
43. Cutting & bending reinforcing steel		X
44. Guardrail components	X	X
	Custom End Sec	Standard Sec
45. Aggregates/Concrete mixes	Covered by WAC 296-127-018	
46. Asphalt	Covered by WAC 296-127-018	
47. Fiber fabrics		X
48. Electrical wiring/components		X
49. treated or untreated timber pile		X
50. Girder pads (elastomeric bearing)	X	
51. Standard Dimension lumber		X
52. Irrigation components		X

ITEM DESCRIPTION	YES	NO
53. Fencing materials		X
54. Guide Posts		X
55. Traffic Buttons		X
56. Epoxy		X
57. Cribbing		X
58. Water distribution materials		X
59. Steel "H" piles		X
60. Steel pipe for concrete pile casings		X
61. Steel pile tips, standard		X
62. Steel pile tips, custom	X	

Prefabricated items specifically produced for public works projects that are prefabricated in a county other than the county wherein the public works project is to be completed, the wage for the offsite prefabrication shall be the applicable prevailing wage for the county in which the actual prefabrication takes place.

It is the manufacturer of the prefabricated product to verify that the correct county wage rates are applied to work they perform.

See RCW [39.12.010](#)

(The definition of "locality" in RCW [39.12.010](#)(2) contains the phrase "wherein the physical work is being performed." The department interprets this phrase to mean the actual work site.

WSDOT's List of State Occupations not applicable to Heavy and Highway Construction Projects

This project is subject to the state hourly minimum rates for wages and fringe benefits in the contract provisions, as provided by the state Department of Labor and Industries.

The following list of occupations, is comprised of those occupations that are not normally used in the construction of heavy and highway projects.

When considering job classifications for use and / or payment when bidding on, or building heavy and highway construction projects for, or administered by WSDOT, these Occupations will be excepted from the included "Washington State Prevailing Wage Rates For Public Work Contracts" documents.

- Building Service Employees
- Electrical Fixture Maintenance Workers
- Electricians - Motor Shop
- Heating Equipment Mechanics
- Industrial Engine and Machine Mechanics
- Industrial Power Vacuum Cleaners
- Inspection, Cleaning, Sealing of Water Systems by Remote Control
- Laborers - Underground Sewer & Water
- Machinists (Hydroelectric Site Work)
- Modular Buildings
- Playground & Park Equipment Installers
- Power Equipment Operators - Underground Sewer & Water
- Residential *** ALL ASSOCIATED RATES ***
- Sign Makers and Installers (Non-Electrical)
- Sign Makers and Installers (Electrical)
- Stage Rigging Mechanics (Non Structural)

The following occupations may be used only as outlined in the preceding text concerning "WSDOT's list for Suppliers - Manufacturers - Fabricators"

- Fabricated Precast Concrete Products
- Metal Fabrication (In Shop)

Definitions for the Scope of Work for prevailing wages may be found at the Washington State Department of Labor and Industries web site and in WAC Chapter 296-127.

**Washington State Department of Labor and Industries
Policy Statements
(Regarding Production and Delivery of Gravel, Concrete, Asphalt, etc.)**

WAC 296-127-018 Agency filings affecting this section

Coverage and exemptions of workers involved in the production and delivery of gravel, concrete, asphalt, or similar materials.

(1) The materials covered under this section include but are not limited to: Sand, gravel, crushed rock, concrete, asphalt, or other similar materials.

(2) All workers, regardless of by whom employed, are subject to the provisions of chapter 39.12 RCW when they perform any or all of the following functions:

(a) They deliver or discharge any of the above-listed materials to a public works project site:

(i) At one or more point(s) directly upon the location where the material will be incorporated into the project; or

(ii) At multiple points at the project; or

(iii) Adjacent to the location and coordinated with the incorporation of those materials.

(b) They wait at or near a public works project site to perform any tasks subject to this section of the rule.

(c) They remove any materials from a public works construction site pursuant to contract requirements or specifications (e.g., excavated materials, materials from demolished structures, clean-up materials, etc.).

(d) They work in a materials production facility (e.g., batch plant, borrow pit, rock quarry, etc.) which is established for a public works project for the specific, but not necessarily exclusive, purpose of supplying materials for the project.

(e) They deliver concrete to a public works site regardless of the method of incorporation.

(f) They assist or participate in the incorporation of any materials into the public works project.

(3) All travel time that relates to the work covered under subsection (2) of this section requires the payment of prevailing wages. Travel time includes time spent waiting to load, loading, transporting, waiting to unload, and delivering materials. Travel time would include all time spent in travel in support of a public works project whether the vehicle is empty or full. For example, travel time spent returning to a supply source to obtain another load of material for use on a public works site or returning to the public works site to obtain another load of excavated material is time spent in travel that is subject to prevailing wage. Travel to a supply source, including travel from a public works site, to obtain materials for use on a private project would not be travel subject to the prevailing wage.

(4) Workers are not subject to the provisions of chapter 39.12 RCW when they deliver materials to a stockpile.

(a) A "stockpile" is defined as materials delivered to a pile located away from the site of incorporation such that the stockpiled materials must be physically moved from the stockpile and transported to another location on the project site in order to be incorporated into the project.

(b) A stockpile does not include any of the functions described in subsection (2)(a) through (f) of this section; nor does a stockpile include materials delivered or distributed to multiple locations upon the project site; nor does a stockpile include materials dumped at the place of incorporation, or adjacent to the location and coordinated with the incorporation.

(5) The applicable prevailing wage rate shall be determined by the locality in which the work is performed. Workers subject to subsection (2)(d) of this section, who produce such materials at an off-site facility shall be paid the applicable prevailing wage rates for the county in which the off-site facility is located. Workers subject to subsection (2) of this section, who deliver such materials to a public works project site shall be paid the applicable prevailing wage rates for the county in which the public works project is located.

[Statutory Authority: Chapter 39.12 RCW, RCW 43.22.051 and 43.22.270. 08-24-101, § 296-127-018, filed 12/2/08, effective 1/2/09. Statutory Authority: Chapters 39.04 and 39.12 RCW and RCW 43.22.270. 92-01-104 and 92-08-101, § 296-127-018, filed 12/18/91 and 4/1/92, effective 8/31/92.]

Benefit Code Key – Effective 8/1/2024 thru 3/4/2025

Overtime Codes

Overtime calculations are based on the hourly rate actually paid to the worker. On public works projects, the hourly rate must be not less than the prevailing rate of wage minus the hourly rate of the cost of fringe benefits actually provided for the worker.

1. ALL HOURS WORKED IN EXCESS OF EIGHT (8) HOURS PER DAY OR FORTY (40) HOURS PER WEEK SHALL BE PAID AT ONE AND ONE-HALF TIMES THE HOURLY RATE OF WAGE.
 - B. All hours worked on Saturdays shall be paid at one and one-half times the hourly rate of wage. All hours worked on Sundays and holidays shall be paid at double the hourly rate of wage.
 - C. The first two (2) hours after eight (8) regular hours Monday through Friday and the first ten (10) hours on Saturday shall be paid at one and one-half times the hourly rate of wage. All other overtime hours and all hours worked on Sundays and holidays shall be paid at double the hourly rate of wage.
 - D. The first two (2) hours before or after a five-eight (8) hour workweek day or a four-ten (10) hour workweek day and the first eight (8) hours worked the next day after either workweek shall be paid at one and one-half times the hourly rate of wage. All additional hours worked and all worked on Sundays and holidays shall be paid at double the hourly rate of wage.
 - E. The first two (2) hours after eight (8) regular hours Monday through Friday and the first eight (8) hours on Saturday shall be paid at one and one-half times the hourly rate of wage. All other hours worked Monday through Saturday, and all hours worked on Sundays and holidays shall be paid at double the hourly rate of wage.
 - F. The first two (2) hours after eight (8) regular hours Monday through Friday and the first ten (10) hours on Saturday shall be paid at one and one-half times the hourly rate of wage. All other overtime hours worked, except Labor Day, shall be paid at double the hourly rate of wage. All hours worked on Labor Day shall be paid at three times the hourly rate of wage.
 - G. The first ten (10) hours worked on Saturdays and the first ten (10) hours worked on a fifth calendar weekday in a four-ten hour schedule, shall be paid at one and one-half times the hourly rate of wage. All hours worked in excess of ten (10) hours per day Monday through Saturday and all hours worked on Sundays and holidays shall be paid at double the hourly rate of wage.
 - H. All hours worked on Saturdays (except makeup days if work is lost due to inclement weather conditions or equipment breakdown) shall be paid at one and one-half times the hourly rate of wage. All hours worked Monday through Saturday over twelve (12) hours and all hours worked on Sundays and holidays shall be paid at double the hourly rate of wage.
 - I. All hours worked on Sundays and holidays shall also be paid at double the hourly rate of wage.
 - J. The first two (2) hours after eight (8) regular hours Monday through Friday and the first ten (10) hours on Saturday shall be paid at one and one-half times the hourly rate of wage. All hours worked over ten (10) hours Monday through Saturday, Sundays and holidays shall be paid at double the hourly rate of wage.
 - K. All hours worked on Saturdays and Sundays shall be paid at one and one-half times the hourly rate of wage. All hours worked on holidays shall be paid at double the hourly rate of wage.
 - M. All hours worked on Saturdays (except makeup days if work is lost due to inclement weather conditions) shall be paid at one and one-half times the hourly rate of wage. All hours worked on Sundays and holidays shall be paid at double the hourly rate of wage.

Overtime Codes Continued

- 1. N. All hours worked on Saturdays (except makeup days) shall be paid at one and one-half times the hourly rate of wage. All hours worked on Sundays and holidays shall be paid at double the hourly rate of wage.
- O. The first ten (10) hours worked on Saturday shall be paid at one and one-half times the hourly rate of wage. All hours worked on Sundays, holidays and after twelve (12) hours, Monday through Friday and after ten (10) hours on Saturday shall be paid at double the hourly rate of wage.
- P. All hours worked on Saturdays (except makeup days if circumstances warrant) and Sundays shall be paid at one and one-half times the hourly rate of wage. All hours worked on holidays shall be paid at double the hourly rate of wage.
- Q. The first two (2) hours after eight (8) regular hours Monday through Friday and up to ten (10) hours worked on Saturdays shall be paid at one and one-half times the hourly rate of wage. All hours worked in excess of ten (10) hours per day Monday through Saturday and all hours worked on Sundays and holidays (except Christmas day) shall be paid at double the hourly rate of wage. All hours worked on Christmas day shall be paid at two and one-half times the hourly rate of wage.
- R. All hours worked on Sundays and holidays shall be paid at two times the hourly rate of wage.
- U. All hours worked on Saturdays shall be paid at one and one-half times the hourly rate of wage. All hours worked on Sundays and holidays (except Labor Day) shall be paid at two times the hourly rate of wage. All hours worked on Labor Day shall be paid at three times the hourly rate of wage.
- V. All hours worked on Sundays and holidays (except Thanksgiving Day and Christmas day) shall be paid at one and one-half times the hourly rate of wage. All hours worked on Thanksgiving Day and Christmas day shall be paid at double the hourly rate of wage.
- W. All hours worked on Saturdays and Sundays (except make-up days due to conditions beyond the control of the employer) shall be paid at one and one-half times the hourly rate of wage. All hours worked on holidays shall be paid at double the hourly rate of wage.
- X. The first four (4) hours after eight (8) regular hours Monday through Friday and the first twelve (12) hours on Saturday shall be paid at one and one-half times the hourly rate of wage. All hours worked over twelve (12) hours Monday through Saturday, Sundays and holidays shall be paid at double the hourly rate of wage. When holiday falls on Saturday or Sunday, the day before Saturday, Friday, and the day after Sunday, Monday, shall be considered the holiday and all work performed shall be paid at double the hourly rate of wage.
- Y. All hours worked outside the hours of 5:00 am and 5:00 pm (or such other hours as may be agreed upon by any employer and the employee) and all hours worked in excess of eight (8) hours per day (10 hours per day for a 4 x 10 workweek) and on Saturdays and holidays (except labor day) shall be paid at one and one-half times the hourly rate of wage. (except for employees who are absent from work without prior approval on a scheduled workday during the workweek shall be paid at the straight-time rate until they have worked 8 hours in a day (10 in a 4 x 10 workweek) or 40 hours during that workweek.) All hours worked Monday through Saturday over twelve (12) hours and all hours worked on Sundays and Labor Day shall be paid at double the hourly rate of wage.
- Z. All hours worked on Saturdays and Sundays shall be paid at one and one-half times the hourly rate of wage. All hours worked on holidays shall be paid the straight time rate of pay in addition to holiday pay.

Overtime Codes Continued

2. ALL HOURS WORKED IN EXCESS OF EIGHT (8) HOURS PER DAY OR FORTY (40) HOURS PER WEEK SHALL BE PAID AT ONE AND ONE-HALF TIMES THE HOURLY RATE OF WAGE.
- B. All hours worked on holidays shall be paid at one and one-half times the hourly rate of wage.
 - F. The first eight (8) hours worked on holidays shall be paid at the straight hourly rate of wage in addition to the holiday pay. All hours worked in excess of eight (8) hours on holidays shall be paid at double the hourly rate of wage.
 - M. This code appears to be missing. All hours worked on Saturdays, Sundays and holidays shall be paid at double the hourly rate of wage.
 - R. All hours worked on Sundays and holidays and all hours worked over sixty (60) in one week shall be paid at double the hourly rate of wage.
 - U. All hours worked on Saturdays shall be paid at one and one-half times the hourly rate of wage. All hours worked over 12 hours in a day or on Sundays and holidays shall be paid at double the hourly rate of wage.
3. ALL HOURS WORKED IN EXCESS OF EIGHT (8) HOURS PER DAY OR FORTY (40) HOURS PER WEEK SHALL BE PAID AT ONE AND ONE-HALF TIMES THE HOURLY RATE OF WAGE.
- F. All hours worked on Saturday shall be paid at one and one-half times the hourly rate of wage. All hours worked on Sunday shall be paid at two times the hourly rate of wage. All hours worked on paid holidays shall be paid at two and one-half times the hourly rate of wage including holiday pay.
 - H. All work performed on Sundays between March 16th and October 14th and all Holidays shall be compensated for at two (2) times the regular rate of pay. Work performed on Sundays between October 15th and March 15th shall be compensated at one and one half (1-1/2) times the regular rate of pay.
 - J. All hours worked between the hours of 10:00 pm and 5:00 am, Monday through Friday, and all hours worked on Saturdays shall be paid at a one and one-half times the hourly rate of wage. All hours worked on Sundays and holidays shall be paid at double the hourly rate of wage.
 - K. Work performed in excess of eight (8) hours of straight time per day, or ten (10) hours of straight time per day when four ten (10) hour shifts are established, or forty (40) hours of straight time per week, Monday through Friday, or outside the normal 5 am to 6pm shift, and all work on Saturdays shall be paid at one and one-half times the hourly rate of wage. All work performed after 6:00 pm Saturday to 5:00 am Monday and Holidays, and all hours worked in excess of twelve (12) hours in a single shift shall be paid at double the hourly rate of wage.

After an employee has worked eight (8) hours at an applicable overtime rate, all additional hours shall be at the applicable overtime rate until such time as the employee has had a break of eight (8) hours or more. When an employee returns to work without at least eight (8) hours time off since their previous shift, all such time shall be a continuation of shift and paid at the applicable overtime rate until he/she shall have the eight (8) hours rest period.

Overtime Codes Continued

4. ALL HOURS WORKED IN EXCESS OF EIGHT (8) HOURS PER DAY OR FORTY (40) HOURS PER WEEK SHALL BE PAID AT ONE AND ONE-HALF TIMES THE HOURLY RATE OF WAGE.

- A. All hours worked in excess of eight (8) hours per day or forty (40) hours per week shall be paid at double the hourly rate of wage. All hours worked on Saturdays, Sundays and holidays shall be paid at double the hourly rate of wage
- C. On Monday through Friday, the first four (4) hours of overtime after eight (8) hours of straight time work shall be paid at one and one half (1-1/2) times the straight time rate of pay, unless a four (4) day ten (10) hour workweek has been established. On a four (4) day ten (10) hour workweek scheduled Monday through Thursday, or Tuesday through Friday, the first two (2) hours of overtime after ten (10) hours of straight time work shall be paid at one and one half (1-1/2) times the straight time rate of pay. On Saturday, the first twelve (12) hours of work shall be paid at one and one half (1-1/2) times the straight time rate of pay, except that if the job is down on Monday through Friday due to weather conditions or other conditions outside the control of the employer, the first ten (10) hours on Saturday may be worked at the straight time rate of pay. All hours worked over twelve (12) hours in a day and all hours worked on Sunday and Holidays shall be paid at two (2) times the straight time rate of pay.
- D. All hours worked in excess of eight (8) hours per day or forty (40) hours per week shall be paid at double the hourly rate of wage. All hours worked on Saturday, Sundays and holidays shall be paid at double the hourly rate of pay. Rates include all members of the assigned crew.

EXCEPTION:

On all multipole structures and steel transmission lines, switching stations, regulating, capacitor stations, generating plants, industrial plants, associated installations and substations, except those substations whose primary function is to feed a distribution system, will be paid overtime under the following rates:

The first two (2) hours after eight (8) regular hours Monday through Friday of overtime on a regular workday, shall be paid at one and one-half times the hourly rate of wage. All hours in excess of ten (10) hours will be at two (2) times the hourly rate of wage. The first eight (8) hours worked on Saturday will be paid at one and one-half (1-1/2) times the hourly rate of wage. All hours worked in excess of eight (8) hours on Saturday, and all hours worked on Sundays and holidays will be at the double the hourly rate of wage.

All overtime eligible hours performed on the above described work that is energized, shall be paid at the double the hourly rate of wage.

- E. The first two (2) hours after eight (8) regular hours Monday through Friday and the first eight (8) hours on Saturday shall be paid at one and one-half times the hourly rate of wage. All other hours worked Monday through Saturday, and all hours worked on Sundays and holidays shall be paid at double the hourly rate of wage.

On a four-day, ten-hour weekly schedule, either Monday thru Thursday or Tuesday thru Friday schedule, all hours worked after ten shall be paid at double the hourly rate of wage. The Monday or Friday not utilized in the normal four-day, ten hour work week, and Saturday shall be paid at one and one half (1½) times the regular shift rate for the first eight (8) hours. All other hours worked Monday through Saturday, and all hours worked on Sundays and holidays shall be paid at double the hourly rate of wage.
- G. All hours worked on Saturdays shall be paid at one and one-half times the hourly rate of wage. All hours worked Monday through Saturday over twelve (12) hours and all hours worked on Sundays and holidays shall be paid at double the hourly rate of wage.
- I. The First eight (8) hours worked on Saturdays shall be paid at one and one-half times the hourly rate of wage. All hours worked in excess of eight (8) per day on Saturdays shall be paid at double the hourly rate of wage. All hours worked on Sundays and holidays shall be paid at double the hourly rate of wage.

Overtime Codes Continued

4. J. The first eight (8) hours worked on a Saturday shall be paid at one and one-half times the hourly rate of wage. All hours worked in excess of eight (8) hours on a Saturday shall be paid at double the hourly rate of wage. All hours worked over twelve (12) in a day, and all hours worked on Sundays and Holidays shall be paid at double the hourly rate of wage.
- K. All hours worked on a Saturday shall be paid at one and one-half times the hourly rate of wage, so long as Saturday is the sixth consecutive day worked. All hours worked over twelve (12) in a day Monday through Saturday, and all hours worked on Sundays and Holidays shall be paid at double the hourly rate of wage.
- L. The first twelve (12) hours worked on a Saturday shall be paid at one and one-half times the hourly rate of wage. All hours worked on a Saturday in excess of twelve (12) hours shall be paid at double the hourly rate of pay. All hours worked over twelve (12) in a day Monday through Friday, and all hours worked on Sundays shall be paid at double the hourly rate of wage. All hours worked on a holiday shall be paid at one and one-half times the hourly rate of wage, except that all hours worked on Labor Day shall be paid at double the hourly rate of pay.
- S. On a four (4) day ten (10) hour workweek scheduled Monday through Thursday, or Tuesday through Friday, work performed in excess of (10) hours shall be paid at one and one half (1-1/2) times the hourly rate of pay. On Monday through Friday, work performed outside the normal work hours of 6:00 a.m. and 6:00 p.m. shall be paid at one and one-half (1-1/2) times the straight time rate, (except for special shifts or multiple shift operations).

All hours worked on Saturdays shall be paid at one and one-half times the hourly rate of wage. All work performed on Sundays and holidays shall be paid at double the hourly rate of wage. When an employee returns to work without at least eight (8) hours time off since their previous shift, all such time shall be a continuation of shift and paid at the applicable overtime rate until such time as the employee has had a break of eight (8) hours.

Multiple Shift Operations: When the first shift of a multiple shift (a two or three shift) operation is started at the basic straight time rate or at a specific overtime rate, all shifts of that day's operation shall be completed at that rate. Special Shifts: The Special Shift Premium is the basic hourly rate of pay plus \$2.00 an hour. When due to conditions beyond the control of the employer or when an owner (not acting as the contractor), a government agency or the contract specifications require more than four (4) hours of a special shift can only be performed outside the normal 6am to 6pm shift then the special shift premium will be applied to the basic straight time for the entire shift. When an employee works on a special shift, they shall be paid the special shift premium for each hour worked unless they are in overtime or double-time status. (For example, the special shift premium does not waive the overtime requirements for work performed on Saturday or Sunday).

- U. The first four (4) hours after eight (8) regular hours Monday through Friday and the first twelve (12) hours on Saturday shall be paid at one and one-half times the hourly rate of wage. (Except on makeup days if work is lost due to inclement weather, then the first eight (8) hours on Saturday may be paid the regular rate.) All hours worked over twelve (12) hours Monday through Saturday, and all hours worked on Sundays and holidays shall be paid at double the hourly rate of wage.

Overtime Codes Continued

4. X. All hours worked on Saturdays shall be paid at one and one-half times the hourly rate of wage. All hours worked on Sundays and holidays shall be paid at double the hourly rate of wage. Work performed outside the normal shift of 6 am to 6pm shall be paid at one and one-half the straight time rate, (except for special shifts or three shift operations). All work performed on Sundays and holidays shall be paid at double the hourly rate of wage. Shifts may be established when considered necessary by the Employer.

The Employer may establish shifts consisting of eight (8) or ten (10) hours of work (subject to WAC 296-127-022), that shall constitute a normal forty (40) hour work week. The Employer can change from a 5-eight to a 4-ten hour schedule or back to the other. All hours of work on these shifts shall be paid for at the straight time hourly rate. Work performed in excess of eight hours (or ten hours per day (subject to WAC 296-127-022) shall be paid at one and one-half the straight time rate.

When due to conditions beyond the control of the Employer, or when contract specifications require that work can only be performed outside the regular day shift, then by mutual agreement a special shift may be worked at the straight time rate, eight (8) hours work for eight (8) hours pay. The starting time shall be arranged to fit such conditions of work.

When an employee returns to work without at a break of eight (8) hours since their previous shift, all such time shall be a continuation of shift and paid at the applicable overtime rate until such time as the employee has had a break of eight (8) hours.

Overtime Codes Continued

11. ALL HOURS WORKED IN EXCESS OF EIGHT (8) HOURS PER DAY OR FORTY (40) HOURS PER WEEK SHALL BE PAID AT ONE AND ONE-HALF TIMES THE HOURLY RATE OF WAGE.

B After an employee has worked eight (8) hours, all additional hours worked shall be paid at the applicable overtime rate until such time as the employee has had a break of eight (8) hours or more.

C The first two (2) hours after eight (8) regular hours Monday through Friday and the first eight (8) hours on Saturday shall be paid at one and one-half times the hourly rate of wage. All other overtime hours worked, except Labor Day, and all hours on Sunday shall be paid at double the hourly rate of wage. All hours worked on Labor Day shall be paid at three times the hourly rate of wage. All non-overtime and non-holiday hours worked between 4:00 pm and 5:00 am, Monday through Friday, shall be paid at a premium rate of 15% over the hourly rate of wage.

D. All hours worked on Saturdays and holidays shall be paid at one and one-half times the hourly rate of wage. All hours worked on Sundays shall be paid at double the hourly rate of wage.

After an employee has worked eight (8) hours, all additional hours worked shall be paid at the applicable overtime rate until such time as the employee has had a break of eight (8) hours or more.

E. The first two (2) hours after eight (8) regular hours Monday through Friday, the first ten (10) hours on Saturday, and the first ten (10) hours worked on Holidays shall be paid at one and one-half times the hourly rate of wage. All hours worked over ten (10) hours Monday through Saturday, and Sundays shall be paid at double the hourly rate of wage.

After an employee has worked eight (8) hours, all additional hours worked shall be paid at the applicable overtime rate until such time as the employee has had a break of eight (8) hours or more.

Overtime Codes Continued

11. F. The first two (2) hours after eight (8) regular hours Monday through Friday and the first eight (8) hours on Saturday shall be paid at one and one-half times the hourly rate of wage. All other hours worked Monday through Saturday, and all hours worked on Sundays and holidays shall be paid at double the hourly rate of wage.
- On a four-day, ten-hour weekly schedule, either Monday thru Thursday or Tuesday thru Friday schedule, all hours worked after ten shall be paid at double the hourly rate of wage. The Monday or Friday not utilized in the normal four-day, ten hour work week, and Saturday shall be paid at one-half times the hourly rate of wage for the first eight (8) hours. All other hours worked Monday through Saturday, and all hours worked on Sundays and holidays shall be paid at double the hourly rate of wage.
- G. Work performed in excess of eight (8) hours of straight time per day, or ten (10) hours of straight time per day when four ten (10) hour shifts are established, or forty (40) hours of straight time per week, Monday through Friday, or outside the normal 5 am to 6pm shift, and all work on Saturdays shall be paid at one and one-half times the hourly rate of wage.
- All work performed after 6:00 pm Saturday to 5:00 am Monday and Holidays, and all hours worked in excess of twelve (12) hours in a single shift shall be paid at double the hourly rate of wage.
- After an employee has worked eight (8) hours at an applicable overtime rate, all additional hours shall be at the applicable overtime rate until such time as the employee has had a break of nine (9) hours or more. When an employee returns to work without at least nine (9) hours time off since their previous shift, all such time shall be a continuation of shift and paid at the applicable overtime rate until he/she shall have the nine (9) hours rest period.
- H. Work performed in excess of eight (8) hours of straight time per day, or ten (10) hours of straight time per day when four ten (10) hour shifts are established, or forty (40) hours of straight time per week, Monday through Friday, or outside the normal 5 am to 6pm shift, and all work on Saturdays shall be paid at one and one-half times the hourly rate of wage.
- All work performed after 6:00 pm Saturday to 5:00 am Monday and Holidays, and all hours worked in excess of twelve (12) hours in a single shift shall be paid at double the hourly rate of wage.
- After an employee has worked eight (8) hours at an applicable overtime rate, all additional hours shall be at the applicable overtime rate until such time as the employee has had a break of ten (10) hours or more. When an employee returns to work without at least ten (10) hours time off since their previous shift, all such time shall be a continuation of shift and paid at the applicable overtime rate until he/she shall have the ten (10) hours rest period.
- J. All hours worked on holidays shall be paid at double the hourly rate of wage.
- K. On Monday through Friday hours worked outside 4:00 am and 5:00 pm, and the first two (2) hours after eight (8) hours worked shall be paid at one and one-half times the hourly rate. All hours worked over 10 hours per day Monday through Friday, and all hours worked on Saturdays, Sundays, and Holidays worked shall be paid at double the hourly rate of wage.
- L. An employee working outside 5:00 am and 5:00 pm shall receive an additional two dollar (\$2.00) per hour for all hours worked that shift. All hours worked on holidays shall be paid at one and one-half times the hourly rate of wage. All hours worked on holidays shall be paid at one and one-half times the hourly rate of wage.

Overtime Codes Continued

11. M. On Monday through Friday, the first four (4) hours of overtime after eight (8) hours of straight time work shall be paid at one and one half (1-1/2) times the straight time rate of pay, unless a four (4) day ten (10) hour workweek has been established. On a four (4) day ten (10) hour workweek scheduled Monday through Thursday, or Tuesday through Friday, the first two (2) hours of overtime after ten (10) hours of straight time work shall be paid at one and one half (1-1/2) times the straight time rate of pay.
- Work performed outside the normal work hours of 5:00 a.m. and 6:00 p.m. shall be paid at one and one-half (1-1/2) times the straight time rate, (except for special shifts or multiple shift operations). When the first shift of a multiple shift (a two or three shift) operation is started at the basic straight time rate or at a specific overtime rate, all shifts of that day's operation shall be completed at that rate. When due to conditions beyond the control of the Employer or when contract specifications require that work can only be performed outside the regular day shift of 5:00 am to 6:00 pm, then a special shift may be worked at the straight time rate, plus the shift pay premium when applicable. The starting time of work will be arranged to fit such conditions of work. Such shift shall consist of eight (8) hours work for eight (8) hours pay or ten (10) hours work for ten (10) hours pay for four ten shifts.
- On Saturday, the first twelve (12) hours of work shall be paid at one and one half (1-1/2) times the straight time rate of pay. All work performed after 6:00 pm Saturday to 5:00 am Monday, all work performed over twelve (12) hours, and all work performed on holidays shall be paid at double the straight time rate of pay.
- Shift Pay Premium: In an addition to any overtime already required, all hours worked between the hours of 6:00 pm and 5:00 am shall receive an additional two dollars (\$2.00) per hour.
- N. All work performed over twelve hours in a shift and all work performed on Sundays and Holidays shall be paid at double the straight time rate.
- Any time worked over eight (8) hours on Saturday shall be paid double the straight time rate, except employees assigned to work six 10-hour shifts per week shall be paid double the straight time rate for any time worked on Saturday over 10 hours.
- O. All work performed on Saturdays, Sundays, and Holidays shall be paid at one and one half (1-1/2) times the straight time rate of pay.

Overtime Codes Continued

11. P. Work performed in excess of ten (10) hours of straight time per day when four ten (10) hour shifts are established and all work on Saturdays, except for make-up days shall be paid at time and one-half (1 ½) the straight time rate.
- Work performed outside the normal work hours of 5:00 a.m. and 6:00 p.m. shall be paid at one and one-half (1-1/2) times the straight time rate, (except for special shifts or multiple shift operations). When the first shift of multiple shift (a two or three shift) operation is started at the basic straight time rate or at a specific overtime rate, all shifts of that day's operation shall be completed at that rate. When due to conditions beyond the control of the Employer or when contract specifications require that work can only be performed outside the regular day shift of 5:00 a.m. to 6:00 p.m., then a special shift may be worked at the straight time rate, plus the shift pay premium when applicable. The starting time of work will be arranged to fit such conditions of work. Such shifts shall consist of eight (8) hours work for eight (8) hours pay or ten (10) hours work for ten (10) hours pay for four ten-hour shifts.
- In the event the job is down due to weather conditions, then Saturday may, be worked as a voluntary make-up day at the straight time rate. However, Saturday shall not be utilized as a make-up day when a holiday falls on Friday. All work performed on Sundays and holidays and work in excess of twelve (12) hours per day shall be paid at double (2x) the straight time rate of pay.
- After an employee has worked eight (8) hours at an applicable overtime rate, all additional hours shall be at the applicable overtime rate until such time as the employee has had a break of eight (8) hours.
- When an employee returns to work without a break of eight (8) hours since their previous shift, all such time shall be a continuation of shift and paid at the applicable overtime rate until such time as the employee has had a break of eight (8) hours.
- Q. All hours worked between the hours of 6:00 pm and 6:00 am, Monday through Saturday, shall be paid at a premium rate of 35% over the hourly rate of wage. Work performed on Sundays shall be paid at double time. All hours worked on holidays shall be paid at double the hourly rate of wage.
- R. On Monday through Saturday hours worked outside 6:00 am and 7:00 pm, and all hours after eight (8) hours worked shall be paid at one and one-half times the hourly rate. All hours worked on Sundays and Holidays shall be paid at double the hourly rate of wage.
- When a holiday falls on a Saturday, the Friday before shall be the observed holiday. When a holiday falls on a Sunday, the following Monday shall be the observed holiday.
- S. The first ten (10) hours worked on Saturdays shall be paid at one and one-half times the hourly rate of wage. In the event the job is down due to weather conditions, or other conditions beyond the control of the Employer, then Saturday may be worked at the straight time rate, for the first eight (8) hours, or the first ten (10) hours when a four day ten hour workweek has been established.
- All hours worked Monday through Saturday over twelve (12) hours and all hours worked on Sundays and holidays shall be paid at double the hourly rate of wage.
- When an employee returns to work without a break of eight (8) hours since their previous shift, all such time shall be a continuation of shift and paid at the applicable overtime rate until such time as the employee has had a break of eight (8) hours.

Benefit Code Key – Effective 8/1/2024 thru 3/4/2025

11. T. On Monday through Friday, the first four (4) hours of overtime after eight (8) hours of straight time work shall be paid at one and one half (1-1/2) times the straight time rate of pay, unless a four (4) day ten (10) hour workweek has been established. On a four (4) day ten (10) hour workweek scheduled Monday through Thursday, or Tuesday through Friday, the first two (2) hours of overtime after ten (10) hours of straight time work shall be paid at one and one half (1-1/2) times the straight time rate of pay.

On Saturday, the first twelve (12) hours of work shall be paid at one and one half (1-1/2) times the straight time rate of pay, except that if the job is down on Monday through Friday due to weather conditions or other conditions outside the control of the employer, the first ten (10) hours on Saturday may be worked at the straight time rate of pay.

All hours worked over twelve (12) hours in a day and all hours worked on Sunday and Holidays shall be paid at two (2) times the straight time rate of pay.

- U. On Monday through Friday, the first four (4) hours of overtime after eight (8) hours of straight time work shall be paid at one and one half (1-1/2) times the straight time rate of pay, unless a four (4) day ten (10) hour workweek has been established. On a four (4) day ten (10) hour workweek scheduled Monday through Thursday, or Tuesday through Friday, the first two (2) hours of overtime after ten (10) hours of straight time work shall be paid at one and one half (1-1/2) times the straight time rate of pay.

On Saturday, the first twelve (12) hours of work shall be paid at one and one half (1-1/2) times the straight time rate of pay, except that if the job is down on Monday through Friday due to weather conditions or other conditions outside the control of the employer, the first ten (10) hours on Saturday may be worked at the straight time rate of pay.

All hours worked over twelve (12) hours in a day and all hours worked on Sunday and Holidays shall be paid at two (2) times the straight time rate of pay.

If, due to conditions beyond the control of the Employer or when contract specifications require that work can only be performed outside the regular day shift, then a Special Shift may be worked, Monday through Friday, at the straight-time rate. The starting time of work for the Special Shift will be arranged to fit such conditions of work. Such Special Shift shall consist of eight (8) hours of work for eight (8) hours of pay or ten (10) hours of work for ten(10) hours of pay on a four-ten workday schedule.

Holiday Codes

5. A. Holidays: New Year's Day, Memorial Day, Independence Day, Labor Day, Thanksgiving Day, Friday after Thanksgiving Day, and Christmas Day (7).
- B. Holidays: New Year's Day, Memorial Day, Independence Day, Labor Day, Thanksgiving Day, Friday after Thanksgiving Day, the day before Christmas, and Christmas Day (8).
- C. Holidays: New Year's Day, Presidents' Day, Memorial Day, Independence Day, Labor Day, Thanksgiving Day, the Friday after Thanksgiving Day, And Christmas Day (8).
- D. Holidays: New Year's Day, Memorial Day, Independence Day, Labor Day, Thanksgiving Day, the Friday and Saturday after Thanksgiving Day, And Christmas Day (8).
- H. Holidays: New Year's Day, Memorial Day, Independence Day, Thanksgiving Day, the Day after Thanksgiving Day, And Christmas (6).

Holiday Codes Continued

- 5. I. Holidays: New Year's Day, Memorial Day, Independence Day, Labor Day, Thanksgiving Day, and Christmas Day (6).
- K. Holidays: New Year's Day, Presidents' Day, Memorial Day, Independence Day, Labor Day, Thanksgiving Day, Friday After Thanksgiving Day, The Day Before Christmas, And Christmas Day (9).
- L. Holidays: New Year's Day, Martin Luther King Jr. Day, Memorial Day, Independence Day, Labor Day, Thanksgiving Day, Friday after Thanksgiving Day, And Christmas Day (8).
- N. Holidays: New Year's Day, Presidents' Day, Memorial Day, Independence Day, Labor Day, Veterans' Day, Thanksgiving Day, The Friday After Thanksgiving Day, And Christmas Day (9).
- P. Holidays: New Year's Day, Memorial Day, Independence Day, Labor Day, Thanksgiving Day, Friday And Saturday After Thanksgiving Day, The Day Before Christmas, And Christmas Day (9). If A Holiday Falls On Sunday, The Following Monday Shall Be Considered As A Holiday.
- Q. Paid Holidays: New Year's Day, Memorial Day, Independence Day, Labor Day, Thanksgiving Day, and Christmas Day (6).
- R. Paid Holidays: New Year's Day, Memorial Day, Independence Day, Labor Day, Thanksgiving Day, Day After Thanksgiving Day, One-Half Day Before Christmas Day, And Christmas Day. (7 1/2).
- S. Paid Holidays: New Year's Day, Presidents' Day, Memorial Day, Independence Day, Labor Day, Thanksgiving Day, And Christmas Day (7).
- Z. Holidays: New Year's Day, Memorial Day, Independence Day, Labor Day, Veterans Day, Thanksgiving Day, the Friday after Thanksgiving Day, And Christmas Day (8).

Holiday Codes Continued

- 6. G. Paid Holidays: New Year's Day, Martin Luther King Jr. Day, Presidents' Day, Memorial Day, Independence Day, Labor Day, Veterans' Day, Thanksgiving Day, the Friday after Thanksgiving Day, Christmas Day, and Christmas Eve Day (11).
- H. Paid Holidays: New Year's Day, New Year's Eve Day, Memorial Day, Independence Day, Labor Day, Thanksgiving Day, Friday After Thanksgiving Day, Christmas Day, The Day After Christmas, And A Floating Holiday (10).
- T. Paid Holidays: New Year's Day, Presidents' Day, Memorial Day, Independence Day, Labor Day, Thanksgiving Day, The Friday After Thanksgiving Day, The Last Working Day Before Christmas Day, And Christmas Day (9).
- Z. Holidays: New Year's Day, Memorial Day, Independence Day, Labor Day, Thanksgiving Day, Friday after Thanksgiving Day, And Christmas Day (7). If a holiday falls on Saturday, the preceding Friday shall be considered as the holiday. If a holiday falls on Sunday, the following Monday shall be considered as the holiday.

Holiday Codes Continued

7. A. Holidays: New Year's Day, Memorial Day, Independence Day, Labor Day, Thanksgiving Day, the Friday and Saturday after Thanksgiving Day, And Christmas Day (8). Any Holiday Which Falls On A Sunday Shall Be Observed As A Holiday On The Following Monday. If any of the listed holidays falls on a Saturday, the preceding Friday shall be a regular work day.
- B. Holidays: New Year's Day, Memorial Day, Independence Day, Labor Day, Thanksgiving Day, the Friday and Saturday after Thanksgiving Day, And Christmas Day (8). Any holiday which falls on a Sunday shall be observed as a holiday on the following Monday. Any holiday which falls on a Saturday shall be observed as a holiday on the preceding Friday.
- C. Holidays: New Year's Day, Martin Luther King Jr. Day, Memorial Day, Independence Day, Labor Day, Thanksgiving Day, the Friday after Thanksgiving Day, And Christmas Day (8). Any holiday which falls on a Sunday shall be observed as a holiday on the following Monday. Any holiday which falls on a Saturday shall be observed as a holiday on the preceding Friday.
- D. Paid Holidays: New Year's Day, Memorial Day, Independence Day, Labor Day, Veteran's Day, Thanksgiving Day, the Friday after Thanksgiving Day, And Christmas Day (8). Unpaid Holidays: President's Day. Any paid holiday which falls on a Sunday shall be observed as a holiday on the following Monday. Any paid holiday which falls on a Saturday shall be observed as a holiday on the preceding Friday.
- E. Holidays: New Year's Day, Memorial Day, Independence Day, Labor Day, Thanksgiving Day, the Friday after Thanksgiving Day, And Christmas Day (7). Any holiday which falls on a Sunday shall be observed as a holiday on the following Monday. Any holiday which falls on a Saturday shall be observed as a holiday on the preceding Friday.
- F. Holidays: New Year's Day, Memorial Day, Independence Day, Labor Day, Thanksgiving Day, the Friday after Thanksgiving Day, the last working day before Christmas day and Christmas day (8). Any holiday which falls on a Sunday shall be observed as a holiday on the following Monday. Any holiday which falls on a Saturday shall be observed as a holiday on the preceding Friday.

Holiday Codes Continued

7. G. Holidays: New Year's Day, Memorial Day, Independence Day, Labor Day, Thanksgiving Day, and Christmas Day (6). Any holiday which falls on a Sunday shall be observed as a holiday on the following Monday.
- H. Holidays: New Year's Day, Martin Luther King Jr. Day, Independence Day, Memorial Day, Labor Day, Thanksgiving Day, the Friday after Thanksgiving Day, the Last Working Day before Christmas Day and Christmas Day (9). Any holiday which falls on a Sunday shall be observed as a holiday on the following Monday. Any holiday which falls on a Saturday shall be observed as a holiday on the preceding Friday.
- I. Holidays: New Year's Day, President's Day, Independence Day, Memorial Day, Labor Day, Thanksgiving Day, The Friday After Thanksgiving Day, The Day Before Christmas Day And Christmas Day (9). Any holiday which falls on a Sunday shall be observed as a holiday on the following Monday. Any holiday which falls on a Saturday shall be observed as a holiday on the preceding Friday.
- J. Holidays: New Year's Day, Independence Day, Memorial Day, Labor Day, Thanksgiving Day and Christmas Day (6). Any holiday which falls on a Sunday shall be observed as a holiday on the following Monday. Any holiday which falls on a Saturday shall be observed as a holiday on the preceding Friday.

Holiday Codes Continued

7. K. Holidays: New Year's Day, Memorial Day, Independence Day, Thanksgiving Day, the Friday and Saturday after Thanksgiving Day, And Christmas Day (8). Any holiday which falls on a Sunday shall be observed as a holiday on the following Monday. Any holiday which falls on a Saturday shall be observed as a holiday on the preceding Friday.
- L. Holidays: New Year's Day, Memorial Day, Labor Day, Independence Day, Thanksgiving Day, the Last Work Day before Christmas Day, And Christmas Day (7). Any holiday which falls on a Sunday shall be observed as a holiday on the following Monday. Any holiday which falls on a Saturday shall be observed as a holiday on the preceding Friday.
- N. Holidays: New Year's Day, Memorial Day, Independence Day, Labor Day, Thanksgiving Day, the Friday after Thanksgiving Day, And Christmas Day (7). Any holiday which falls on a Sunday shall be observed as a holiday on the following Monday. When Christmas falls on a Saturday, the preceding Friday shall be observed as a holiday.
- P. Holidays: New Year's Day, Memorial Day, Independence Day, Labor Day, Thanksgiving Day, Friday after Thanksgiving Day, And Christmas Day (7). Any holiday which falls on a Sunday shall be observed as a holiday on the following Monday.
- Q. Holidays: New Year's Day, Memorial Day, Independence Day, Labor Day, Thanksgiving Day, the Friday after Thanksgiving Day, the Last Working Day before Christmas Day and Christmas Day (8). Any holiday which falls on a Sunday shall be observed as a holiday on the following Monday. If any of the listed holidays falls on a Saturday, the preceding Friday shall be a regular work day.
- S. Paid Holidays: New Year's Day, Memorial Day, Independence Day, Labor Day, Thanksgiving Day, Friday after Thanksgiving Day, Christmas Day, the Day after Christmas, and A Floating Holiday (9). If any of the listed holidays falls on a Sunday, the day observed by the Nation shall be considered a holiday and compensated accordingly.
- V. Holidays: New Year's Day, President's Birthday, Memorial Day, Independence Day, Labor Day, Thanksgiving Day, the Friday after Thanksgiving Day, Christmas Day, the day before or after Christmas, and the day before or after New Year's Day. If any of the above listed holidays falls on a Sunday, the day observed by the Nation shall be considered a holiday and compensated accordingly.
- W. Holidays: New Year's Day, Day After New Year's, Memorial Day, Independence Day, Labor Day, Thanksgiving Day, the Friday after Thanksgiving Day, Christmas Eve Day, Christmas Day, the day after Christmas, the day before New Year's Day, and a Floating Holiday.
- X. Holidays: New Year's Day, Day before or after New Year's Day, Presidents' Day, Memorial Day, Independence Day, Labor Day, Thanksgiving Day, the Friday after Thanksgiving Day, Christmas Day, and the day before or after Christmas day. If a holiday falls on a Saturday or on a Friday that is the normal day off, then the holiday will be taken on the last normal workday. If the holiday falls on a Monday that is the normal day off or on a Sunday, then the holiday will be taken on the next normal workday.
- Y. Holidays: New Year's Day, Presidents' Day, Memorial Day, Independence Day, Labor Day, Thanksgiving Day, the Friday after Thanksgiving Day, and Christmas Day. (8) If the holiday falls on a Sunday, then the day observed by the federal government shall be considered a holiday and compensated accordingly.
- Z. Holidays: New Year's Day, Memorial Day, Independence Day, Labor Day, Thanksgiving Day, the Friday and Saturday after Thanksgiving Day, Christmas Eve, and Christmas Day (9). Any holiday which falls on a Saturday shall be observed as a holiday on the preceding Friday. Any holiday which falls on a Sunday shall be observed as a holiday on the following Monday.

Holiday Codes Continued

15. G. New Year's Day, Washington's Birthday, Memorial Day, Independence Day, Labor Day, Thanksgiving Day, The Friday After Thanksgiving Day, the last scheduled workday before Christmas, and Christmas Day (9). If any of the listed holidays falls on a Sunday, the day observed by the Nation shall be considered a holiday and compensated accordingly.
- H. Holidays: New Year's Day, Martin Luther King Jr. Day, Independence Day, Memorial Day, Labor Day, Thanksgiving Day, the Friday after Thanksgiving Day, the Last Working Day before Christmas Day and Christmas Day (9). Any holiday which falls on a Sunday shall be observed as a holiday on the following Monday. Any holiday which falls on a Saturday shall be observed as a holiday on the preceding Friday.
- I. Holidays: New Year's Day, President's Day, Independence Day, Memorial Day, Labor Day, Thanksgiving Day, The Friday After Thanksgiving Day, The Day Before Christmas Day And Christmas Day (9). Any holiday which falls on a Sunday shall be observed as a holiday on the following Monday. Any holiday which falls on a Saturday shall be observed as a holiday on the preceding Friday.
- J. Holidays: New Year's Day, Martin Luther King Jr. Day, Memorial Day, Independence Day, Labor Day, Thanksgiving Day, the Friday and Saturday after Thanksgiving Day, and Christmas Day (9). Any holiday which falls on a Sunday shall be observed as a holiday on the following Monday. If any of the listed holidays falls on a Saturday, the preceding Friday shall be a regular work day.
- K. Holidays: New Year's Day, Memorial Day, Independence Day, Thanksgiving Day, the Friday and Saturday after Thanksgiving Day, And Christmas Day (8). Any holiday which falls on a Sunday shall be observed as a holiday on the following Monday. Any holiday which falls on a Saturday shall be observed as a holiday on the preceding Friday.
- L. Holidays: New Year's Day, Memorial Day, Independence Day, Labor Day, Veteran's Day, Thanksgiving Day, the Friday after Thanksgiving Day, and Christmas Day (8). Any holiday which falls on a Sunday shall be observed as a holiday on the following Monday. If any of the listed holidays falls on a Saturday, the preceding Friday shall be a regular work day.
- M. Holidays: New Year's Day, Martin Luther King Jr. Day, Independence Day, Memorial Day, Labor Day, Thanksgiving Day, the Friday after Thanksgiving Day, Christmas Eve Day and Christmas Day (9). Any holiday which falls on a Sunday shall be observed as a holiday on the following Monday. If any of the listed holidays falls on a Saturday, the preceding Friday shall be a regular work day.
- N. Holidays: New Year's Day, Memorial Day, Independence Day, Labor Day, Veteran's Day, Thanksgiving Day, the Friday after Thanksgiving Day, and Christmas Day (8). Any holiday which falls on a Sunday shall be observed as a holiday on the following Monday.
- O. Holidays: New Year's Day, Martin Luther King Jr. Day, Memorial Day, Independence Day, Labor Day, Thanksgiving Day, the Friday and Saturday after Thanksgiving Day, the day before Christmas day, and Christmas Day (10). Any holiday which falls on a Sunday shall be observed as a holiday on the following Monday.

Benefit Code Key – Effective 8/1/2024 thru 3/4/2025

Note Codes

8. D. Workers working with supplied air on hazmat projects receive an additional \$1.00 per hour.
- L. Workers on hazmat projects receive additional hourly premiums as follows -Level A: \$0.75, Level B: \$0.50, And Level C: \$0.25.
- M. Workers on hazmat projects receive additional hourly premiums as follows: Levels A & B: \$1.00, Levels C & D: \$0.50.
- N. Workers on hazmat projects receive additional hourly premiums as follows -Level A: \$1.00, Level B: \$0.75, Level C: \$0.50, And Level D: \$0.25.
- S. Effective August 31, 2012 – A Traffic Control Supervisor shall be present on the project whenever flagging or spotting or other traffic control labor is being utilized. Flaggers and Spotters shall be posted where shown on approved Traffic Control Plans or where directed by the Engineer. All flaggers and spotters shall possess a current flagging card issued by the State of Washington, Oregon, Montana, or Idaho. This classification is only effective on or after August 31, 2012.
- T. Effective August 31, 2012 – A Traffic Control Laborer performs the setup, maintenance and removal of all temporary traffic control devices and construction signs necessary to control vehicular, bicycle, and pedestrian traffic during construction operations. Flaggers and Spotters shall be posted where shown on approved Traffic Control Plans or where directed by the Engineer. All flaggers and spotters shall possess a current flagging card issued by the State of Washington, Oregon, Montana, or Idaho. This classification is only effective on or after August 31, 2012.
- U. Workers on hazmat projects receive additional hourly premiums as follows – Class A Suit: \$2.00, Class B Suit: \$1.50, And Class C Suit: \$1.00. Workers performing underground work receive an additional \$0.40 per hour for any and all work performed underground, including operating, servicing and repairing of equipment. The premium for underground work shall be paid for the entire shift worked. Workers who work suspended by a rope or cable receive an additional \$0.50 per hour. The premium for work suspended shall be paid for the entire shift worked. Workers who do “pioneer” work (break open a cut, build road, etc.) more than one hundred fifty (150) feet above grade elevation receive an additional \$0.50 per hour.
8. V. In addition to the hourly wage and fringe benefits, the following depth and enclosure premiums shall be paid. The premiums are to be calculated for the maximum depth and distance into an enclosure that a diver reaches in a day. The premiums are to be paid one time for the day and are not used in calculating overtime pay.
- Depth premiums apply to depths of fifty feet or more. Over 50' to 100' - \$2.00 per foot for each foot over 50 feet. Over 101' to 150' - \$3.00 per foot for each foot over 101 feet. Over 151' to 220' - \$4.00 per foot for each foot over 220 feet. Over 221' - \$5.00 per foot for each foot over 221 feet.
- Enclosure premiums apply when divers enter enclosures (such as pipes or tunnels) where there is no vertical ascent and is measured by the distance travelled from the entrance. 25' to 300' - \$1.00 per foot from entrance. 300' to 600' - \$1.50 per foot beginning at 300'. Over 600' - \$2.00 per foot beginning at 600'.
- W. Meter Installers work on single phase 120/240V self-contained residential meters. The Lineman/Groundmen rates would apply to meters not fitting this description.

Note Codes Continued

- X. Workers on hazmat projects receive additional hourly premiums as follows - Class A Suit: \$2.00, Class B Suit: \$1.50, Class C Suit: \$1.00, and Class D Suit: \$0.50. Special Shift Premium: Basic hourly rate plus \$2.00 per hour.

When due to conditions beyond the control of the Employer or when an owner (not acting as the contractor), a government agency or the contract specifications requires that work can only be performed outside the normal 5 am to 6pm shift, then the special shift premium will be applied to the basic hourly rate. When an employee works on a special shift, they shall be paid a special shift premium for each hour worked unless they are in OT or Double-time status. (For example, the special shift premium does not waive the overtime requirements for work performed on Saturday or Sunday.)

- Y. Tide Work: When employees are called out between the hours of 6:00 p.m. and 6:00 a.m. to work on tide work (work located in the tide plane) all time worked shall be at one and one-half times the hourly rate of pay.

Swinging Stage/Boatswains Chair: Employees working on a swinging state or boatswains chair or under conditions that require them to be tied off to allow their hands to be free shall receive seventy-five cents (\$0.75) per hour above the classification rate.

- Z. Workers working with supplied air on hazmat projects receive an additional \$1.00 per hour.

Special Shift Premium: Basic hourly rate plus \$2.00 per hour. When due to conditions beyond the control of the Employer or when an owner (not acting as a contractor), a government agency or the contract specifications require that more than (4) hours of a special shift can only be performed outside the normal 6 am to 6pm shift, then the special shift premium will be applied to the basic straight time for the entire shift. When an employee works on a special shift, they will be paid a special shift premium for each hour worked unless they are in overtime or double-time status. (For example, the special shift premium does not waive the overtime requirements for work performed on Saturday or Sunday.)

Note Codes Continued

9. A. Workers working with supplied air on hazmat projects receive an additional \$1.00 per hour.

Special Shift Premium: Basic hourly rate plus \$2.00 per hour. When due to conditions beyond the control of the Employer or when an owner (not acting as the contractor), a government agency or the contract specifications require that more than four (4) hours of a special shift can only be performed outside the normal 6 am to 6pm shift, then the special shift premium will be applied to the basic straight time for the entire shift. When an employee works on a special shift, they shall be paid a special shift premium for each hour worked unless they are in overtime or double-time status. (For example, the special shift premium does not waive the overtime requirements for work performed on Saturday or Sunday.)

Certified Crane Operator Premium: Crane operators requiring certifications shall be paid \$0.50 per hour above their classification rate.

Boom Pay Premium: All cranes including tower shall be paid as follows based on boom length:

- (A) – 130’ to 199’ – \$0.50 per hour over their classification rate.
- (B) – 200’ to 299’ – \$0.80 per hour over their classification rate.
- (C) – 300’ and over – \$1.00 per hour over their classification rate.

Note Codes Continued

9. B. The highest pressure registered on the gauge for an accumulated time of more than fifteen (15) minutes during the shift shall be used in determining the scale paid.

Tide Work: When employees are called out between the hours of 6:00 p.m. and 6:00 a.m. to work on tide work (work located in the tide plane) all time worked shall be at one and one-half times the hourly rate of pay. Swinging Stage/Boatswains Chair: Employees working on a swinging stage or boatswains chair or under conditions that require them to be tied off to allow their hands to be free shall receive seventy-five cents (\$0.75) per hour above the classification rate.

- C. Tide Work: When employees are called out between the hours of 6:00 p.m. and 6:00 a.m. to work on tide work (work located in the tide plane) all time worked shall be at one and one-half times the hourly rate of pay. Swinging Stage/Boatswains Chair: Employees working on a swinging stage or boatswains chair or under conditions that require them to be tied off to allow their hands to be free shall receive seventy-five cents (\$0.75) per hour above the classification rate.

Effective August 31, 2012 – A Traffic Control Supervisor shall be present on the project whenever flagging or spotting or other traffic control labor is being utilized. A Traffic Control Laborer performs the setup, maintenance and removal of all temporary traffic control devices and construction signs necessary to control vehicular, bicycle, and pedestrian traffic during construction operations. Flaggers and Spotters shall be posted where shown on approved Traffic Control Plans or where directed by the Engineer. All flaggers and spotters shall possess a current flagging card issued by the State of Washington, Oregon, Montana, or Idaho. These classifications are only effective on or after August 31, 2012.

- D. Industrial Painter wages are required for painting within industrial facilities such as treatment plants, pipelines, towers, dams, bridges, power generation facilities and manufacturing facilities such as chemical plants, etc., or anywhere abrasive blasting is necessary to prepare surfaces, or hazardous materials encapsulation is required.
- E. Heavy Construction includes construction, repair, alteration or additions to the production, fabrication or manufacturing portions of industrial or manufacturing plants, hydroelectric or nuclear power plants and atomic reactor construction. Workers on hazmat projects receive additional hourly premiums as follows -Level A: \$1.00, Level B: \$0.75, Level C: \$0.50, And Level D: \$0.25.
- F. Industrial Painter wages are required for painting within industrial facilities such as treatment plants, pipelines, towers, dams, power generation facilities and manufacturing facilities such as chemical plants, etc., or anywhere abrasive blasting is necessary to prepare surfaces, or hazardous materials encapsulation is required.
- H. One (1) person crew shall consist of a Party Chief. (Total Station or similar one (1) person survey system). Two (2) person survey party shall consist of a least a Party Chief and a Chain Person. Three (3) person survey party shall consist of at least a Party Chief, an Instrument Person, and a Chain Person.

Benefit Code Key – Effective 8/1/2024 thru 3/4/2025

9. I. In addition to the hourly wage and fringe benefits, the following depth and enclosure premiums shall be paid. The premiums are to be calculated for the maximum depth and distance into an enclosure that a diver reaches in a day. The premiums are to be paid one time for the day and are not used in calculating overtime pay.

Depth premiums apply to depths of fifty feet or more. Over 50' to 100' - \$2.00 per foot for each foot over 50 feet. Over 101' to 150' - \$3.00 per foot for each foot over 101 feet. Over 151' to 220' - \$4.00 per foot for each foot over 220 feet. Over 221' - \$5.00 per foot for each foot over 221 feet.

Enclosure premiums apply when divers enter enclosures (such as pipes or tunnels) where there is no vertical ascent and is measured by the distance travelled from the entrance. 25' to 300' - \$1.00 per foot from entrance. 300' to 600' - \$1.50 per foot beginning at 300'. Over 600' - \$2.00 per foot beginning at 600'.

Employees may be required to perform any combination of work within the Diving team/crew, (with the exception of dive Supervisor) provided they are paid at the highest rate at which he/she has worked for the shift.

- L. Workers on hazmat projects receive additional hourly premiums as follows -Level A: \$0.75, Level B: \$0.50, And Level C: \$0.25.

Tide Work: When employees are called out between the hours of 6:00 p.m. and 6:00 a.m. to work on tide work (work located in the tide plane) all time worked shall be at one and one-half times the hourly rate of pay.

Swinging Stage/Boatswains Chair: Employees working on a swinging stage or boatswains chair or under conditions that require them to be tied off to allow their hands to be free shall receive seventy-five cents (\$0.75) per hour above the classification rate.

State of Washington
 Department of Labor & Industries
 Prevailing Wage Section - Telephone 360-902-5335
 PO Box 44540, Olympia, WA 98504-4540

Washington State Prevailing Wage

The PREVAILING WAGES listed here include both the hourly wage rate and the hourly rate of fringe benefits. On public works projects, worker's wage and benefit rates must add to not less than this total. A brief description of overtime calculation requirements are provided on the Benefit Code Key.

Journey Level Prevailing Wage Rates for the Effective Date: 10/1/2024

County	Trade	Job Classification	Wage	Holiday	Overtime	Note	*Risk Class
Pierce	Cement Masons	Application of all Composition Mastic	\$77.30	15J	4U		View
Pierce	Cement Masons	Application of all Epoxy Material	\$76.78	15J	4U		View
Pierce	Cement Masons	Application of all Plastic Material	\$77.30	15J	4U		View
Pierce	Cement Masons	Application of Sealing Compound	\$76.78	15J	4U		View
Pierce	Cement Masons	Application of Underlayment	\$77.30	15J	4U		View
Pierce	Cement Masons	Building General	\$76.78	15J	4U		View
Pierce	Cement Masons	Composition or Kalman Floors	\$77.30	15J	4U		View
Pierce	Cement Masons	Concrete Paving	\$76.78	15J	4U		View
Pierce	Cement Masons	Curb & Gutter Machine	\$77.30	15J	4U		View
Pierce	Cement Masons	Curb & Gutter, Sidewalks	\$76.78	15J	4U		View
Pierce	Cement Masons	Curing Concrete	\$76.78	15J	4U		View
Pierce	Cement Masons	Finish Colored Concrete	\$77.30	15J	4U		View
Pierce	Cement Masons	Floor Grinding	\$77.30	15J	4U		View
Pierce	Cement Masons	Floor Grinding/Polisher	\$76.78	15J	4U		View
Pierce	Cement Masons	Green Concrete Saw, self-powered	\$77.30	15J	4U		View
Pierce	Cement Masons	Grouting of all Plates	\$76.78	15J	4U		View
Pierce	Cement Masons	Grouting of all Tilt-up Panels	\$76.78	15J	4U		View
Pierce	Cement Masons	Gunite Nozzleman	\$77.30	15J	4U		View
Pierce	Cement Masons	Hand Powered Grinder	\$77.30	15J	4U		View
Pierce	Cement Masons	Journey Level	\$76.78	15J	4U		View
Pierce	Cement Masons	Patching Concrete	\$76.78	15J	4U		View
Pierce	Cement Masons	Pneumatic Power Tools	\$77.30	15J	4U		View
Pierce	Cement Masons	Power Chipping & Brushing	\$77.30	15J	4U		View
Pierce	Cement Masons	Sand Blasting Architectural Finish	\$77.30	15J	4U		View
Pierce	Cement Masons	Screed & Rodding Machine	\$77.30	15J	4U		View
Pierce	Cement Masons	Spackling or Skim Coat Concrete	\$76.78	15J	4U		View
Pierce	Cement Masons	Troweling Machine Operator	\$77.30	15J	4U		View
Pierce	Cement Masons	Troweling Machine Operator on Colored Slabs	\$77.30	15J	4U		View
Pierce	Cement Masons	Tunnel Workers	\$77.30	15J	4U		View
Pierce	Flaggers	Journey Level	\$53.68	15J	11P	8Y	View
Pierce	Laborers	Air, Gas Or Electric Vibrating Screed	\$62.68	15J	11P	8Y	View
Pierce	Laborers	Airtrac Drill Operator	\$64.51	15J	11P	8Y	View
Pierce	Laborers	Ballast Regular Machine	\$62.68	15J	11P	8Y	View

Pierce	Laborers	Batch Weighman	\$53.68	15J	11P	8Y	View
Pierce	Laborers	Brick Pavers	\$62.68	15J	11P	8Y	View
Pierce	Laborers	Brush Cutter	\$62.68	15J	11P	8Y	View
Pierce	Laborers	Brush Hog Feeder	\$62.68	15J	11P	8Y	View
Pierce	Laborers	Burner	\$62.68	15J	11P	8Y	View
Pierce	Laborers	Caisson Worker	\$64.51	15J	11P	8Y	View
Pierce	Laborers	Carpenter Tender	\$62.68	15J	11P	8Y	View
Pierce	Laborers	Cement Dumper-paving	\$63.76	15J	11P	8Y	View
Pierce	Laborers	Cement Finisher Tender	\$62.68	15J	11P	8Y	View
Pierce	Laborers	Change House Or Dry Shack	\$62.68	15J	11P	8Y	View
Pierce	Laborers	Chipping Gun (30 Lbs. And Over)	\$63.76	15J	11P	8Y	View
Pierce	Laborers	Chipping Gun (Under 30 Lbs.)	\$62.68	15J	11P	8Y	View
Pierce	Laborers	Choker Setter	\$62.68	15J	11P	8Y	View
Pierce	Laborers	Chuck Tender	\$62.68	15J	11P	8Y	View
Pierce	Laborers	Clary Power Spreader	\$63.76	15J	11P	8Y	View
Pierce	Laborers	Clean-up Laborer	\$62.68	15J	11P	8Y	View
Pierce	Laborers	Concrete Dumper/Chute Operator	\$63.76	15J	11P	8Y	View
Pierce	Laborers	Concrete Form Stripper	\$62.68	15J	11P	8Y	View
Pierce	Laborers	Concrete Placement Crew	\$63.76	15J	11P	8Y	View
Pierce	Laborers	Concrete Saw Operator/Core Driller	\$63.76	15J	11P	8Y	View
Pierce	Laborers	Crusher Feeder	\$53.68	15J	11P	8Y	View
Pierce	Laborers	Curing Laborer	\$62.68	15J	11P	8Y	View
Pierce	Laborers	Demolition: Wrecking & Moving (Incl. Charred Material)	\$62.68	15J	11P	8Y	View
Pierce	Laborers	Ditch Digger	\$62.68	15J	11P	8Y	View
Pierce	Laborers	Diver	\$64.51	15J	11P	8Y	View
Pierce	Laborers	Drill Operator (Hydraulic, Diamond)	\$63.76	15J	11P	8Y	View
Pierce	Laborers	Dry Stack Walls	\$62.68	15J	11P	8Y	View
Pierce	Laborers	Dump Person	\$62.68	15J	11P	8Y	View
Pierce	Laborers	Epoxy Technician	\$62.68	15J	11P	8Y	View
Pierce	Laborers	Erosion Control Worker	\$62.68	15J	11P	8Y	View
Pierce	Laborers	Faller & Bucker Chain Saw	\$63.76	15J	11P	8Y	View
Pierce	Laborers	Fine Graders	\$62.68	15J	11P	8Y	View
Pierce	Laborers	Firewatch	\$53.68	15J	11P	8Y	View
Pierce	Laborers	Form Setter	\$63.76	15J	11P	8Y	View
Pierce	Laborers	Gabian Basket Builders	\$62.68	15J	11P	8Y	View
Pierce	Laborers	General Laborer	\$62.68	15J	11P	8Y	View
Pierce	Laborers	Grade Checker & Transit Person	\$66.10	15J	11P	8Y	View
Pierce	Laborers	Grinders	\$62.68	15J	11P	8Y	View
Pierce	Laborers	Grout Machine Tender	\$62.68	15J	11P	8Y	View
Pierce	Laborers	Groutmen (Pressure) Including Post Tension Beams	\$63.76	15J	11P	8Y	View
Pierce	Laborers	Guardrail Erector	\$62.68	15J	11P	8Y	View
Pierce	Laborers	Hazardous Waste Worker (Level A)	\$64.51	15J	11P	8Y	View
Pierce	Laborers	Hazardous Waste Worker (Level B)	\$63.76	15J	11P	8Y	View
Pierce	Laborers	Hazardous Waste Worker (Level C)	\$62.68	15J	11P	8Y	View
Pierce	Laborers	High Scaler	\$64.51	15J	11P	8Y	View
Pierce	Laborers	Jackhammer	\$63.76	15J	11P	8Y	View
Pierce	Laborers	Laserbeam Operator	\$63.76	15J	11P	8Y	View
Pierce	Laborers	Maintenance Person	\$62.68	15J	11P	8Y	View

Pierce	Laborers	Manhole Builder-Mudman	\$63.76	15J	11P	8Y	View
Pierce	Laborers	Material Yard Person	\$62.68	15J	11P	8Y	View
Pierce	Laborers	Mold Abatement Worker	\$62.68	15J	11P	8Y	View
Pierce	Laborers	Motorman-Dinky Locomotive	\$66.20	15J	11P	8Y	View
Pierce	Laborers	nozzleman (concrete pump, green cutter when using combination of high pressure air & water on concrete & rock, sandblast, gunite, shotcrete, water blaster, vacuum blaster)	\$66.10	15J	11P	8Y	View
Pierce	Laborers	Pavement Breaker	\$63.76	15J	11P	8Y	View
Pierce	Laborers	Pilot Car	\$53.68	15J	11P	8Y	View
Pierce	Laborers	Pipe Layer (Lead)	\$66.10	15J	11P	8Y	View
Pierce	Laborers	Pipe Layer/Tailor	\$63.76	15J	11P	8Y	View
Pierce	Laborers	Pipe Pot Tender	\$63.76	15J	11P	8Y	View
Pierce	Laborers	Pipe Reliner	\$63.76	15J	11P	8Y	View
Pierce	Laborers	Pipe Wrapper	\$63.76	15J	11P	8Y	View
Pierce	Laborers	Pot Tender	\$62.68	15J	11P	8Y	View
Pierce	Laborers	Powderman	\$64.51	15J	11P	8Y	View
Pierce	Laborers	Powderman's Helper	\$62.68	15J	11P	8Y	View
Pierce	Laborers	Power Jacks	\$63.76	15J	11P	8Y	View
Pierce	Laborers	Railroad Spike Puller - Power	\$63.76	15J	11P	8Y	View
Pierce	Laborers	Raker - Asphalt	\$66.10	15J	11P	8Y	View
Pierce	Laborers	Re-timberman	\$64.51	15J	11P	8Y	View
Pierce	Laborers	Remote Equipment Operator	\$63.76	15J	11P	8Y	View
Pierce	Laborers	Rigger/Signal Person	\$63.76	15J	11P	8Y	View
Pierce	Laborers	Rip Rap Person	\$62.68	15J	11P	8Y	View
Pierce	Laborers	Rivet Buster	\$63.76	15J	11P	8Y	View
Pierce	Laborers	Rodder	\$63.76	15J	11P	8Y	View
Pierce	Laborers	Scaffold Erector	\$62.68	15J	11P	8Y	View
Pierce	Laborers	Scale Person	\$62.68	15J	11P	8Y	View
Pierce	Laborers	Sloper (Over 20")	\$63.76	15J	11P	8Y	View
Pierce	Laborers	Sloper Sprayer	\$62.68	15J	11P	8Y	View
Pierce	Laborers	Spreader (Concrete)	\$63.76	15J	11P	8Y	View
Pierce	Laborers	Stake Hopper	\$62.68	15J	11P	8Y	View
Pierce	Laborers	Stock Piler	\$62.68	15J	11P	8Y	View
Pierce	Laborers	Swinging Stage/Boatswain Chair	\$53.68	15J	11P	8Y	View
Pierce	Laborers	Tamper & Similar Electric, Air & Gas Operated Tools	\$63.76	15J	11P	8Y	View
Pierce	Laborers	Tamper (Multiple & Self-propelled)	\$63.76	15J	11P	8Y	View
Pierce	Laborers	Timber Person - Sewer (Lagger, Shorer & Cribber)	\$63.76	15J	11P	8Y	View
Pierce	Laborers	Toolroom Person (at Jobsite)	\$62.68	15J	11P	8Y	View
Pierce	Laborers	Topper	\$62.68	15J	11P	8Y	View
Pierce	Laborers	Track Laborer	\$62.68	15J	11P	8Y	View
Pierce	Laborers	Track Liner (Power)	\$63.76	15J	11P	8Y	View
Pierce	Laborers	Traffic Control Laborer	\$57.15	15J	11P	9C	View
Pierce	Laborers	Traffic Control Supervisor	\$60.34	15J	11P	9C	View
Pierce	Laborers	Truck Spotter	\$62.68	15J	11P	8Y	View
Pierce	Laborers	Tugger Operator	\$63.76	15J	11P	8Y	View
Pierce	Laborers	Tunnel Work-Compressed Air Worker 0-30 psi	\$200.40	15J	11P	9B	View

Pierce	Laborers	Tunnel Work-Compressed Air Worker 30.01-44.00 psi	\$205.43	15J	11P	9B	View
Pierce	Laborers	Tunnel Work-Compressed Air Worker 44.01-54.00 psi	\$209.11	15J	11P	9B	View
Pierce	Laborers	Tunnel Work-Compressed Air Worker 54.01-60.00 psi	\$214.81	15J	11P	9B	View
Pierce	Laborers	Tunnel Work-Compressed Air Worker 60.01-64.00 psi	\$216.93	15J	11P	9B	View
Pierce	Laborers	Tunnel Work-Compressed Air Worker 64.01-68.00 psi	\$222.03	15J	11P	9B	View
Pierce	Laborers	Tunnel Work-Compressed Air Worker 68.01-70.00 psi	\$223.93	15J	11P	9B	View
Pierce	Laborers	Tunnel Work-Compressed Air Worker 70.01-72.00 psi	\$225.93	15J	11P	9B	View
Pierce	Laborers	Tunnel Work-Compressed Air Worker 72.01-74.00 psi	\$227.93	15J	11P	9B	View
Pierce	Laborers	Tunnel Work-Guage and Lock Tender	\$66.20	15J	11P	8Y	View
Pierce	Laborers	Tunnel Work-Miner	\$66.20	15J	11P	8Y	View
Pierce	Laborers	Vibrator	\$63.76	15J	11P	8Y	View
Pierce	Laborers	Vinyl Seamer	\$62.68	15J	11P	8Y	View
Pierce	Laborers	Watchman	\$49.12	15J	11P	8Y	View
Pierce	Laborers	Welder	\$63.76	15J	11P	8Y	View
Pierce	Laborers	Well Point Laborer	\$63.76	15J	11P	8Y	View
Pierce	Laborers	Window Washer /Cleaner	\$49.12	15J	11P	8Y	View
Pierce	Power Equipment Operators	Asphalt Plant Operator	\$84.67	15J	3K	8X	View
Pierce	Power Equipment Operators	Assistant Engineer	\$78.95	7A	11H	8X	View
Pierce	Power Equipment Operators	Barrier Machine (zipper)	\$83.92	15J	3K	8X	View
Pierce	Power Equipment Operators	Batch Plant Operator: Concrete	\$83.92	15J	3K	8X	View
Pierce	Power Equipment Operators	Bobcat	\$79.65	15J	3K	8X	View
Pierce	Power Equipment Operators	Brokk - Remote Demolition Equipment	\$79.65	15J	3K	8X	View
Pierce	Power Equipment Operators	Brooms	\$79.65	15J	3K	8X	View
Pierce	Power Equipment Operators	Bump Cutter	\$83.92	15J	3K	8X	View
Pierce	Power Equipment Operators	Cableways	\$84.67	15J	3K	8X	View
Pierce	Power Equipment Operators	Chipper	\$83.92	15J	3K	8X	View
Pierce	Power Equipment Operators	Compressor	\$79.65	15J	3K	8X	View
Pierce	Power Equipment Operators	Concrete Pump: Truck Mount With Boom Attachment Over 42m	\$84.67	15J	3K	8X	View
Pierce	Power Equipment Operators	Concrete Finish Machine -laser Screed	\$79.65	15J	3K	8X	View
Pierce	Power Equipment Operators	Concrete Pump - Mounted Or Trailer High Pressure Line Pump, Pump High Pressure	\$83.28	15J	3K	8X	View
Pierce	Power Equipment Operators	Concrete Pump: Truck Mount With Boom Attachment Up To 42m	\$83.92	15J	3K	8X	View
Pierce	Power Equipment Operators	Conveyors	\$83.28	15J	3K	8X	View
Pierce	Power Equipment Operators	Cranes Friction: 200 tons and over	\$86.48	7A	11H	8X	View
Pierce	Power Equipment Operators	Cranes, A-frame: 10 tons and under	\$78.95	7A	11H	8X	View
Pierce	Power Equipment Operators	Cranes: 100 tons through 199 tons, or 150' of boom (including jib with attachments)	\$84.77	7A	11H	8X	View
Pierce	Power Equipment Operators	Cranes: 20 tons through 44 tons with attachments	\$83.20	7A	11H	8X	View

Pierce	Power Equipment Operators	Cranes: 200 tons- 299 tons, or 250' of boom including jib with attachments	\$85.66	7A	11H	8X	View
Pierce	Power Equipment Operators	Cranes: 300 tons and over or 300' of boom including jib with attachments	\$86.48	7A	11H	8X	View
Pierce	Power Equipment Operators	Cranes: 45 tons through 99 tons, under 150' of boom(including jib with attachments)	\$83.95	7A	11H	8X	View
Pierce	Power Equipment Operators	Cranes: Friction cranes through 199 tons	\$85.66	7A	11H	8X	View
Pierce	Power Equipment Operators	Cranes: through 19 tons with attachments, A-frame over 10 tons	\$82.56	7A	11H	8X	View
Pierce	Power Equipment Operators	Crusher	\$83.92	15J	3K	8X	View
Pierce	Power Equipment Operators	Deck Engineer/deck Winches (power)	\$83.92	15J	3K	8X	View
Pierce	Power Equipment Operators	Derricks: on building work	\$83.95	7A	11H	8X	View
Pierce	Power Equipment Operators	Dozers D-9 & Under	\$83.28	15J	3K	8X	View
Pierce	Power Equipment Operators	Drill Oilers: Auger Type, Truck Or Crane Mount	\$83.28	15J	3K	8X	View
Pierce	Power Equipment Operators	Drilling Machine	\$85.53	15J	3K	8X	View
Pierce	Power Equipment Operators	Elevator and man-lift: permanent and shaft type	\$78.95	7A	11H	8X	View
Pierce	Power Equipment Operators	Finishing Machine, Bidwell And Gamaco & Similar Equipment	\$83.92	15J	3K	8X	View
Pierce	Power Equipment Operators	Forklift: 3000 lbs and over with attachments	\$82.56	7A	11H	8X	View
Pierce	Power Equipment Operators	Forklifts: under 3000 lbs. with attachments	\$78.95	7A	11H	8X	View
Pierce	Power Equipment Operators	Grade Engineer: Using Blueprints, Cut Sheets,etc.	\$83.92	15J	3K	8X	View
Pierce	Power Equipment Operators	Gradechecker/stakeman	\$79.65	15J	3K	8X	View
Pierce	Power Equipment Operators	Guardrail punch/Auger	\$83.92	15J	3K	8X	View
Pierce	Power Equipment Operators	Hard Tail End Dump Articulating Off- Road Equipment 45 Yards. & Over	\$84.67	15J	3K	8X	View
Pierce	Power Equipment Operators	Hard Tail End Dump Articulating Off-road Equipment Under 45 Yards	\$83.92	15J	3K	8X	View
Pierce	Power Equipment Operators	Horizontal/directional Drill Locator	\$83.28	15J	3K	8X	View
Pierce	Power Equipment Operators	Horizontal/directional Drill Operator	\$83.92	15J	3K	8X	View
Pierce	Power Equipment Operators	Hydralifts/boom trucks: 10 tons and under	\$78.95	7A	11H	8X	View
Pierce	Power Equipment Operators	Hydralifts/boom trucks: over 10 tons	\$82.56	7A	11H	8X	View
Pierce	Power Equipment Operators	Loader, Overhead 8 Yards. & Over	\$85.53	15J	3K	8X	View
Pierce	Power Equipment Operators	Loader, Overhead, 6 Yards. But Not Including 8 Yards	\$84.67	15J	3K	8X	View
Pierce	Power Equipment Operators	Loaders, Overhead Under 6 Yards	\$83.92	15J	3K	8X	View
Pierce	Power Equipment Operators	Loaders, Plant Feed	\$83.92	15J	3K	8X	View
Pierce	Power Equipment Operators	Loaders: Elevating Type Belt	\$83.28	15J	3K	8X	View
Pierce	Power Equipment Operators	Locomotives, All	\$83.92	15J	3K	8X	View
Pierce	Power Equipment Operators	Material Transfer Device	\$83.92	15J	3K	8X	View
Pierce	Power Equipment Operators	Mechanics: all (Leadmen - \$0.50 per hour over mechanic)	\$84.77	7A	11H	8X	View

Pierce	Power Equipment Operators	Motor patrol graders	\$84.67	15J	3K	8X	View
Pierce	Power Equipment Operators	Mucking Machine, Mole, Tunnel Drill, Boring, Road Header And/or Shield	\$84.67	15J	3K	8X	View
Pierce	Power Equipment Operators	Oil Distributors, Blower Distribution & Mulch Seeding Operator	\$79.65	15J	3K	8X	View
Pierce	Power Equipment Operators	Outside Hoists (elevators and manlifts), Air Tuggers, Strato	\$82.56	7A	11H	8X	View
Pierce	Power Equipment Operators	Overhead, bridge type Crane: 20 tons through 44 tons	\$83.20	7A	11H	8X	View
Pierce	Power Equipment Operators	Overhead, bridge type: 100 tons and over	\$84.77	7A	11H	8X	View
Pierce	Power Equipment Operators	Overhead, bridge type: 45 tons through 99 tons	\$83.95	7A	11H	8X	View
Pierce	Power Equipment Operators	Pavement Breaker	\$79.65	15J	3K	8X	View
Pierce	Power Equipment Operators	Pile Driver (other Than Crane Mount)	\$83.92	15J	3K	8X	View
Pierce	Power Equipment Operators	Plant Oiler - Asphalt, Crusher	\$83.28	15J	3K	8X	View
Pierce	Power Equipment Operators	Posthole Digger, Mechanical	\$79.65	15J	3K	8X	View
Pierce	Power Equipment Operators	Power Plant	\$79.65	15J	3K	8X	View
Pierce	Power Equipment Operators	Pumps - Water	\$79.65	15J	3K	8X	View
Pierce	Power Equipment Operators	Quad 9, HD 41, D10 And Over	\$84.67	15J	3K	8X	View
Pierce	Power Equipment Operators	Quick Tower: no cab, under 100 feet in height based to boom	\$78.95	7A	11H	8X	View
Pierce	Power Equipment Operators	Remote Control Operator On Rubber Tired Earth Moving Equipment	\$84.67	15J	3K	8X	View
Pierce	Power Equipment Operators	Rigger and Bellman	\$78.95	7A	11H	8X	View
Pierce	Power Equipment Operators	Rigger/Signal Person, Bellman(Certified)	\$82.56	7A	11H	8X	View
Pierce	Power Equipment Operators	Rollagon	\$84.67	15J	3K	8X	View
Pierce	Power Equipment Operators	Roller, Other Than Plant Mix	\$79.65	15J	3K	8X	View
Pierce	Power Equipment Operators	Roller, Plant Mix Or Multi-lift Materials	\$83.28	15J	3K	8X	View
Pierce	Power Equipment Operators	Roto-mill, Roto-grinder	\$83.92	15J	3K	8X	View
Pierce	Power Equipment Operators	Saws - Concrete	\$83.28	15J	3K	8X	View
Pierce	Power Equipment Operators	Scraper, Self Propelled Under 45 Yards	\$83.92	15J	3K	8X	View
Pierce	Power Equipment Operators	Scrapers - Concrete & Carry All	\$83.28	15J	3K	8X	View
Pierce	Power Equipment Operators	Scrapers, Self-propelled: 45 Yards And Over	\$84.67	15J	3K	8X	View
Pierce	Power Equipment Operators	Service Engineers: equipment	\$82.56	7A	11H	8X	View
Pierce	Power Equipment Operators	Shotcrete/gunite Equipment	\$79.65	15J	3K	8X	View
Pierce	Power Equipment Operators	Shovel, Excavator, Backhoe, Tractors Under 15 Metric Tons	\$83.28	15J	3K	8X	View
Pierce	Power Equipment Operators	Shovel, Excavator, Backhoe: Over 30 Metric Tons To 50 Metric Tons	\$84.67	15J	3K	8X	View
Pierce	Power Equipment Operators	Shovel, Excavator, Backhoes, Tractors: 15 To 30 Metric Tons	\$83.92	15J	3K	8X	View
Pierce	Power Equipment Operators	Shovel, Excavator, Backhoes: Over 50 Metric Tons To 90 Metric Tons	\$85.53	15J	3K	8X	View
Pierce	Power Equipment Operators	Shovel, Excavator, Backhoes: Over 90 Metric Tons	\$86.39	15J	3K	8X	View
Pierce	Power Equipment Operators	Slipform Pavers	\$84.67	15J	3K	8X	View
Pierce	Power Equipment Operators	Spreader, Topsider & Screedman	\$84.67	15J	3K	8X	View

Pierce	Power Equipment Operators	Subgrader Trimmer	\$83.92	15J	3K	8X	View
Pierce	Power Equipment Operators	Tower Bucket Elevators	\$83.28	15J	3K	8X	View
Pierce	Power Equipment Operators	Tower Crane: over 175' through 250' in height, base to boom	\$85.66	7A	11H	8X	View
Pierce	Power Equipment Operators	Tower crane: up to 175' in height base to boom	\$84.77	7A	11H	8X	View
Pierce	Power Equipment Operators	Tower Cranes: over 250' in height from base to boom.	\$86.48	7A	11H	8X	View
Pierce	Power Equipment Operators	Transporters, All Track Or Truck Type	\$84.67	15J	3K	8X	View
Pierce	Power Equipment Operators	Trenching Machines	\$83.28	15J	3K	8X	View
Pierce	Power Equipment Operators	Truck Crane Oiler/Driver: 100 tons and over	\$83.20	7A	11H	8X	View
Pierce	Power Equipment Operators	Truck crane oiler/driver: under 100 tons	\$82.56	7A	11H	8X	View
Pierce	Power Equipment Operators	Truck Mount Portable Conveyor	\$83.92	15J	3K	8X	View
Pierce	Power Equipment Operators	Vac Truck (Vactor Guzzler, Hydro Excavator)	\$83.92	15J	3K	8X	View
Pierce	Power Equipment Operators	Welder	\$83.95	7A	11H	8X	View
Pierce	Power Equipment Operators	Wheel Tractors, Farmall Type	\$79.65	15J	3K	8X	View
Pierce	Power Equipment Operators	Yo Yo Pay Dozer	\$83.92	15J	3K	8X	View
Pierce	Street And Parking Lot Sweeper Workers	Journey Level	\$21.69		1		View
Pierce	Surveyors	Assistant Construction Site Surveyor	\$82.56	7A	11H	8X	View
Pierce	Surveyors	Chainman	\$78.95	7A	11H	8X	View
Pierce	Surveyors	Construction Site Surveyor	\$83.95	7A	11H	8X	View
Pierce	Surveyors	Drone Operator (when used in conjunction with surveying work only)	\$78.95	7A	11H	8X	View
Pierce	Surveyors	Ground Penetrating Radar	\$78.95	7A	11H	8X	View
Pierce	Traffic Control Stripers	Journey Level	\$92.44	15L	1K		View
Pierce	Truck Drivers	Asphalt Mix Over 16 Yards	\$79.40	15J	11M	8L	View
Pierce	Truck Drivers	Asphalt Mix To 16 Yards	\$78.56	15J	11M	8L	View
Pierce	Truck Drivers	Dump Truck	\$78.56	15J	11M	8L	View
Pierce	Truck Drivers	Dump Truck & Trailer	\$79.40	15J	11M	8L	View
Pierce	Truck Drivers	Other Trucks	\$79.40	15J	11M	8L	View
Pierce	Truck Drivers - Ready Mix	Transit Mix	\$79.40	15J	11M	8L	View

Appendix B

Federal Wage Rates

Superseded General Decision Number: WA20230001

State: Washington

Construction Type: Highway

Counties: Washington Statewide.

HIGHWAY (Excludes D.O.E. Hanford Site in Benton and Franklin Counties)

Note: Contracts subject to the Davis-Bacon Act are generally required to pay at least the applicable minimum wage rate required under Executive Order 14026 or Executive Order 13658. Please note that these Executive Orders apply to covered contracts entered into by the federal government that are subject to the Davis-Bacon Act itself, but do not apply to contracts subject only to the Davis-Bacon Related Acts, including those set forth at 29 CFR 5.1(a)(1).

<p>If the contract is entered into on or after January 30, 2022, or the contract is renewed or extended (e.g., an option is exercised) on or after January 30, 2022:</p>	<ul style="list-style-type: none"> . Executive Order 14026 generally applies to the contract. . The contractor must pay all covered workers at least \$17.20 per hour (or the applicable wage rate listed on this wage determination, if it is higher) for all hours spent performing on the contract in 2024.
<p>If the contract was awarded on or between January 1, 2015 and January 29, 2022, and the contract is not renewed or extended on or after January 30, 2022:</p>	<ul style="list-style-type: none"> . Executive Order 13658 generally applies to the contract. . The contractor must pay all covered workers at least \$12.90 per hour (or the applicable wage rate listed on this wage determination, if it is higher) for all hours spent performing on that contract in 2024.

The applicable Executive Order minimum wage rate will be adjusted annually. If this contract is covered by one of the Executive Orders and a classification considered necessary for performance of work on the contract does not appear on this wage determination, the contractor must still submit a conformance request.

Additional information on contractor requirements and worker protections under the Executive Orders is available at <http://www.dol.gov/whd/govcontracts>.

Modification Number	Publication Date
0	01/05/2024
1	01/19/2024
2	02/02/2024
3	03/08/2024
4	05/24/2024
5	09/06/2024
6	09/27/2024

SOUTHWEST WASHINGTON: CLARK, COWLITZ, KLUCKITAT, LEWIS(Piledriver only), PACIFIC (South of a straight line made by extending the north boundary line of Wahkiakum County west to Willapa Bay to the Pacific Ocean), SKAMANIA, and WAHAKIAKUM Counties.

	Rates	Fringes
Carpenters:		
CARPENTERS.....	\$ 44.38	16.87
DIVERS TENDERS.....	\$ 49.09	16.87
DIVERS.....	\$ 93.09	16.87
DRYWALL.....	\$ 44.38	16.87
MILLWRIGHTS.....	\$ 46.89	16.87
PILEDRIVERS.....	\$ 44.97	16.87

DEPTH PAY:
 50 TO 100 FEET \$1.00 PER FOOT OVER 50 FEET
 101 TO 150 FEET \$1.50 PER FOOT OVER 101 FEET
 151 TO 200 FEET \$2.00 PER FOOT OVER 151 FEET

Zone Differential (Add up Zone 1 rates):
 Zone 2 - \$0.85
 Zone 3 - 1.25
 Zone 4 - 1.70
 Zone 5 - 2.00
 Zone 6 - 3.00

BASEPOINTS: ASTORIA, LONGVIEW, PORTLAND, THE DALLES, AND VANCOUVER, (NOTE: All dispatches for Washington State Counties: Cowlitz, Wahkiakum and Pacific shall be from Longview Local #1707 and mileage shall be computed from that point.)

ZONE 1: Projects located within 30 miles of the respective city hall of the above mentioned cities
 ZONE 2: Projects located more than 30 miles and less than 40 miles of the respective city of the above mentioned cities
 ZONE 3: Projects located more than 40 miles and less than 50 miles of the respective city of the above mentioned cities
 ZONE 4: Projects located more than 50 miles and less than 60 miles of the respective city of the above mentioned cities.
 ZONE 5: Projects located more than 60 miles and less than 70 miles of the respective city of the above mentioned cities
 ZONE 6: Projects located more than 70 miles of the respected city of the above mentioned cities

CLALLAM, GRAYS HARBOR, ISLAND, JEFFERSON, KING, KITSAP, LEWIS, MASON, PACIFIC (North of a straight line made by extending the north boundary line of Wahkiakum County west to the Pacific Ocean), PIERCE, SAN JUAN, SKAGIT, SNOHOMISH, THURSTON AND WHATCOM Counties

	Rates	Fringes
CARPENTER		
BRIDGE CARPENTERS.....	\$ 49.18	19.01
CARPENTERS ON CREOSOTE		
MATERIAL.....	\$ 47.02	19.01
CARPENTERS.....	\$ 49.18	19.01
DIVERS TENDER.....	\$ 54.54	19.01
DIVERS.....	\$ 103.43	19.01

MILLWRIGHT AND MACHINE		
ERECTORS.....	\$ 50.68	19.01
PILEDRIIVER, DRIVING, PULLING, CUTTING, PLACING COLLARS, SETTING, WELDING OR CRESOTE TREATED		
MATERIAL, ALL PILING.....	\$ 49.58	19.01

(HOURLY ZONE PAY: WESTERN AND CENTRAL WASHINGTON - ALL CLASSIFICATIONS EXCEPT MILLWRIGHTS AND PILEDRIIVERS)

Hourly Zone Pay shall be paid on jobs located outside of the free zone computed from the city center of the following listed cities:

Seattle	Olympia	Bellingham
Auburn	Bremerton	Anacortes
Renton	Shelton	Yakima
Aberdeen-Hoquiam	Tacoma	Wenatchee
Ellensburg	Everett	Port Angeles
Centralia	Mount Vernon	Sunnyside
Chelan	Pt. Townsend	

Zone Pay:

0 -25 radius miles	Free
26-35 radius miles	\$1.00/hour
36-45 radius miles	\$1.15/hour
46-55 radius miles	\$1.35/hour
Over 55 radius miles	\$1.55/hour

(HOURLY ZONE PAY: WESTERN AND CENTRAL WASHINGTON - MILLWRIGHT AND PILEDRIIVER ONLY)

Hourly Zone Pay shall be computed from Seattle Union Hall, Tacoma City center, and Everett City center

Zone Pay:

0 -25 radius miles	Free
26-45 radius miles	\$.70/hour
Over 45 radius miles	\$1.50/hour

 CARP0059-002 06/01/2024

ADAMS, ASOTIN, BENTON, CHELAN (East of 120th meridian), COLUMBIA, DOUGLAS, FERRY, FRANKLIN, GARFIELD, GRANT (East of 120th meridian), KITTITAS (East of 120th meridian), LINCOLN, OKANOGAN (East of 120th meridian), PEND OREILLE, SPOKANE, STEVENS, WALLA WALLA, WHITMAN, and YAKIMA (East of 120th meridian) Counties

	Rates	Fringes
CARPENTER		
GROUP 1.....	\$ 41.86	16.56
GROUP 2.....	\$ 47.42	18.96
GROUP 3.....	\$ 47.41	16.61
GROUP 4.....	\$ 45.86	16.56
GROUP 5.....	\$ 105.46	16.56
GROUP 6.....	\$ 51.73	16.56
GROUP 7.....	\$ 52.73	16.56
GROUP 8.....	\$ 48.41	16.56
GROUP 9.....	\$ 55.73	16.56

CARPENTER & DIVER CLASSIFICATIONS:

GROUP 1: Carpenter

GROUP 2: Millwright, Machine Erector

GROUP 3: Piledriver - includes driving, pulling, cutting, placing collars, setting, welding, or creosote treated material, on all piling

GROUP 4: Bridge, Dock, and Wharf carpenters

GROUP 5: Diver Wet

GROUP 6: Diver Tender, Manifold Operator, ROV Operator

GROUP 7: Diver Standby

GROUP 8: Assistant Diver Tender, ROV Tender/Technician

GROUP 9: Manifold Operator-Mixed Gas

ZONE PAY:

ZONE 1	0-45 MILES	FREE
ZONE 2	45-100	\$4.00/PER HOUR
ZONE 3	OVER 100 MILES	\$6.00/PER HOUR

DISPATCH POINTS:

CARPENTERS/MILLWRIGHTS: PASCO (515 N Neel Street) or Main Post Office of established residence of employee (Whichever is closest to the worksite).

CARPENTERS/PILEDRIVER: SPOKANE (127 E. AUGUSTA AVE.) or Main Post Office of established residence of employee (Whichever is closest to the worksite).

CARPENTERS: WENATCHEE (27 N. CHELAN) or Main Post Office of established residence of employee (Whichever is closest to the worksite).

CARPENTERS: COEUR D' ALENE (1839 N. GOVERNMENT WAY) or Main Post Office of established residence of employee (Whichever is closest to the worksite).

CARPENTERS: MOSCOW (306 N. JACKSON) or Main Post Office of established residence of employee (Whichever is closest to the worksite).

DEPTH PAY FOR DIVERS BELOW WATER SURFACE:

50-100 feet	\$2.00 per foot
101-150 feet	\$3.00 per foot
151-220 feet	\$4.00 per foot
221 feet and deeper	\$5.00 per foot

PREMIUM PAY FOR DIVING IN ENCLOSURES WITH NO VERTICAL ASCENT:

0-25 feet	Free
26-300 feet	\$1.00 per Foot

SATURATION DIVING:

The standby rate applies until saturation starts. The saturation diving rate applies when divers are under pressure continuously until work task and decompression are complete. the diver rate shall be paid for all saturation hours.

WORK IN COMBINATION OF CLASSIFICATIONS:

Employees working in any combination of classifications within the diving crew (except dive supervisor) in a shift are paid in the classification with the highest rate for that shift.

HAZMAT PROJECTS:

Anyone working on a HAZMAT job (task), where HAZMAT certification is required, shall be compensated at a

premium, in addition to the classification working in as follows:

LEVEL D + \$.25 per hour - This is the lowest level of protection. No respirator is used and skin protection is minimal.

LEVEL C + \$.50 per hour - This level uses an air purifying respirator or additional protective clothing.

LEVEL B + \$.75 per hour - Uses same respirator protection as Level A. Supplied air line is provided in conjunction with a chemical "splash suit".

LEVEL A +\$1.00 per hour - This level utilizes a fully encapsulated suit with a self-contained breathing apparatus or a supplied air line.

CARP0770-003 06/01/2021

WEST OF 120TH MERIDIAN FOR THE FOLLOWING COUNTIES:
CHELAN, DOUGLAS, GRANT, KITTITAS, OKANOGAN, and YAKIMA

	Rates	Fringes
CARPENTER		
CARPENTERS ON CREOSOTE		
MATERIAL.....	\$ 47.02	19.01
CARPENTERS.....	\$ 49.18	19.01
DIVERS TENDER.....	\$ 54.54	19.01
DIVERS.....	\$ 103.43	19.01
MILLWRIGHT AND MACHINE		
ERECTORS.....	\$ 50.68	19.01
PILED RIVER, DRIVING, PULLING, CUTTING, PLACING COLLARS, SETTING, WELDING OR CREOSOTE TREATED		
MATERIAL, ALL PILING.....	\$ 49.58	19.01

(HOURLY ZONE PAY: WESTERN AND CENTRAL WASHINGTON - ALL CLASSIFICATIONS EXCEPT MILLWRIGHTS AND PILED RIVERS)

Hourly Zone Pay shall be paid on jobs located outside of the free zone computed from the city center of the following listed cities:

Seattle	Olympia	Bellingham
Auburn	Bremerton	Anacortes
Renton	Shelton	Yakima
Aberdeen-Hoquiam	Tacoma	Wenatchee
Ellensburg	Everett	Port Angeles
Centralia	Mount Vernon	Sunnyside
Chelan	Pt. Townsend	

Zone Pay:

0 -25 radius miles	Free
26-35 radius miles	\$1.00/hour
36-45 radius miles	\$1.15/hour
46-55 radius miles	\$1.35/hour
Over 55 radius miles	\$1.55/hour

(HOURLY ZONE PAY: WESTERN AND CENTRAL WASHINGTON - MILLWRIGHT AND PILED RIVER ONLY)

Hourly Zone Pay shall be computed from Seattle Union Hall, Tacoma City center, and Everett City center

Zone Pay:

0 -25 radius miles Free
 26-45 radius miles \$.70/hour
 Over 45 radius miles \$1.50/hour

 ELEC0046-001 08/07/2023

CALLAM, JEFFERSON, KING AND KITSAP COUNTIES

	Rates	Fringes
CABLE SPLICER.....	\$ 76.99	28.60
ELECTRICIAN.....	\$ 69.99	28.39

 * ELEC0048-003 01/01/2024

CLARK, KLICKITAT AND SKAMANIA COUNTIES

	Rates	Fringes
CABLE SPLICER.....	\$ 44.22	21.50
ELECTRICIAN.....	\$ 60.50	28.64

HOURLY ZONE PAY:

Hourly Zone Pay shall be paid on jobs located outside of the free zone computed from the city center of the following listed cities:

Portland, The Dalles, Hood River, Tillamook, Seaside and Astoria

- Zone Pay:
 Zone 1: 31-50 miles \$1.50/hour
 Zone 2: 51-70 miles \$3.50/hour
 Zone 3: 71-90 miles \$5.50/hour
 Zone 4: Beyond 90 miles \$9.00/hour

*These are not miles driven. Zones are based on Delorme Street Atlas USA 2006 plus.

 ELEC0048-029 01/01/2024

COWLITZ AND WAHKIAKUM COUNTY

	Rates	Fringes
CABLE SPLICER.....	\$ 44.22	21.50
ELECTRICIAN.....	\$ 60.50	28.64

 * ELEC0073-001 07/01/2024

ADAMS, FERRY, LINCOLN, PEND OREILLE, SPOKANE, STEVENS, WHITMAN COUNTIES

	Rates	Fringes
CABLE SPLICER.....	\$ 34.10	16.68
ELECTRICIAN.....	\$ 47.55	18.03

 ELEC0076-002 02/02/2024

GRAYS HARBOR, LEWIS, MASON, PACIFIC, PIERCE, AND THURSTON COUNTIES

Rates	Fringes
-------	---------

CABLE SPLICER.....	\$ 64.38	25.64
ELECTRICIAN.....	\$ 58.53	25.47

ELEC0112-005 06/01/2022

ASOTIN, BENTON, COLUMBIA, FRANKLIN, GARFIELD, KITTITAS, WALLA
WALLA, YAKIMA COUNTIES

	Rates	Fringes
CABLE SPLICER.....	\$ 54.34	24.26
ELECTRICIAN.....	\$ 51.75	24.18

ELEC0191-003 06/01/2022

ISLAND, SAN JUAN, SNOHOMISH, SKAGIT AND WHATCOM COUNTIES

	Rates	Fringes
CABLE SPLICER.....	\$ 44.23	17.73
ELECTRICIAN.....	\$ 53.20	27.51

ELEC0191-004 06/01/2018

CHELAN, DOUGLAS, GRANT AND OKANOGAN COUNTIES

	Rates	Fringes
CABLE SPLICER.....	\$ 40.82	17.63
ELECTRICIAN.....	\$ 42.45	21.34

ENGI0302-003 06/01/2023

CHELAN (WEST OF THE 120TH MERIDIAN), CLALLAM, DOUGLAS (WEST OF
THE 120TH MERIDIAN), GRAYS HARBOR, ISLAND, JEFFERSON, KING,
KITSAP, KITTITAS, MASON, OKANOGAN (WEST OF THE 120TH MERIDIAN),
SAN JUNA, SKAGIT, SNOHOMISH, WHATCOM AND YAKIMA (WEST OF THE
120TH MERIDIAN) COUNTIES

Zone 1 (0-25 radius miles):

	Rates	Fringes
POWER EQUIPMENT OPERATOR		
Group 1A.....	\$ 54.93	25.57
Group 1AA.....	\$ 55.75	25.57
Group 1AAA.....	\$ 56.54	25.57
Group 1.....	\$ 54.13	25.57
Group 2.....	\$ 53.42	25.57
Group 3.....	\$ 52.83	25.57
Group 4.....	\$ 49.40	25.57

Zone Differential (Add to Zone 1 rates):

- Zone 2 (26-45 radius miles) - \$1.00
- Zone 3 (Over 45 radius miles) - \$1.30

BASEPOINTS: Aberdeen, Bellingham, Bremerton, Everett, Kent,
Mount Vernon, Port Angeles, Port Townsend, Seattle,
Shelton, Wenatchee, Yakima

POWER EQUIPMENT OPERATORS CLASSIFICATIONS

GROUP 1AAA - Cranes-over 300 tons, or 300 ft of boom
(including jib with attachments)

GROUP 1AA - Cranes 200 to 300 tons, or 250 ft of boom

(including jib with attachments); Tower crane over 175 ft in height, base to boom

GROUP 1A - Cranes, 100 tons thru 199 tons, or 150 ft of boom (including jib with attachments); Crane-overhead, bridge type, 100 tons and over; Tower crane up to 175 ft in height base to boom; Loaders-overhead, 8 yards and over; Shovels, excavator, backhoes-6 yards and over with attachments

GROUP 1 - Cableway; Cranes 45 tons thru 99 tons, under 150 ft of boom (including jib with attachments); Crane-overhead, bridge type, 45 tons thru 99 tons; Derricks on building work; Excavator, shovel, backhoes over 3 yards and under 6 yards; Hard tail end dump articulating off-road equipment 45 yards and over; Loader- overhead 6 yards to, but not including 8 yards; Mucking machine, mole, tunnel, drill and/or shield; Quad 9, HD 41, D-10; Remote control operator on rubber tired earth moving equipment; Rollagon; Scrapers-self propelled 45 yards and over; Slipform pavers; Transporters, all truck or track type

GROUP 2 - Barrier machine (zipper); Batch Plant Operator-Concrete; Bump Cutter; Cranes, 20 tons thru 44 tons with attachments; Crane-overhead, bridge type-20 tons through 44 tons; Chipper; Concrete Pump-truck mount with boom attachment; Crusher; Deck Engineer/Deck Winches (power); Drilling machine; Excavator, shovel, backhoe-3yards and under; Finishing Machine, Bidwell, Gamaco and similar equipment; Guardrail punch; Horizontal/directional drill operator; Loaders-overhead under 6 yards; Loaders-plant feed; Locomotives-all; Mechanics-all; Mixers-asphalt plant; Motor patrol graders-finishing; Piledriver (other than crane mount); Roto-mill, roto-grinder; Screedman, spreader, topside operator-Blaw Knox, Cedar Rapids, Jaeger, Caterpillar, Barbar Green; Scraper-self propelled, hard tail end dump, articulating off-road equipment-under 45 yards; Subgrade trimmer; Tractors, backhoes-over 75 hp; Transfer material service machine-shuttle buggy, blaw knox-roadtec; Truck crane oiler/driver-100 tons and over; Truck Mount portable conveyor; Yo Yo Pay dozer

GROUP 3 - Conveyors; Cranes-thru 19 tons with attachments; A-frame crane over 10 tons; Drill oilers-auger type, truck or crane mount; Dozers-D-9 and under; Forklift-3000 lbs. and over with attachments; Horizontal/directional drill locator; Outside hoists-(elevators and manlifts), air tuggers, strato tower bucket elevators; Hydralifts/boom trucks over 10 tons; Loader-elevating type, belt; Motor patrol grader-nonfinishing; Plant oiler- asphalt, crusher; Pumps-concrete; Roller, plant mix or multi-lift materials; Saws-concrete; Scrapers-concrete and carry-all; Service engineer-equipment; Trenching machines; Truck Crane Oiler/Driver under 100 tons; Tractors, backhoe 75 hp and under

GROUP 4 - Assistant Engineer; Bobcat; Brooms; Compressor; Concrete finish machine-laser screed; Cranes-A frame-10 tons and under; Elevator and Manlift-permanent or shaft type; Gradechecker, Stakehop; Forklifts under 3000 lbs. with attachments; Hydralifts/boom trucks, 10 tons and under; Oil distributors, blower distribution and mulch seeding operator; Pavement breaker; Posthole digger, mechanical; Power plant; Pumps, water; Rigger and Bellman; Roller-other than plant mix; Wheel Tractors, farmall type; Shotcrete/gunite equipment operator

HANDLING OF HAZARDOUS WASTE MATERIALS:

Personnel in all craft classifications subject to working inside a federally designated hazardous perimeter shall be

eligible for compensation in accordance with the following group schedule relative to the level of hazardous waste as outlined in the specific hazardous waste project site safety plan.

H-1 Base wage rate when on a hazardous waste site when not outfitted with protective clothing

H-2 Class "C" Suit - Base wage rate plus \$.25 per hour.

H-3 Class "B" Suit - Base wage rate plus \$.50 per hour.

H-4 Class "A" Suit - Base wage rate plus \$.75 per hour.

ENGI0370-002 06/01/2024

ADAMS, ASOTIN, BENTON, CHELAN (EAST OF THE 120TH MERIDIAN), COLUMBIA, DOUGLAS (EAST OF THE 120TH MERIDIAN), FERRY, FRANKLIN, GARFIELD, GRANT, LINCOLN, OKANOGAN (EAST OF THE 120TH MERIDIAN), PEND OREILLE, SPOKANE, STEVENS, WALLA WALLA, WHITMAN AND YAKIMA (EAST OF THE 120TH MERIDIAN) COUNTIES

ZONE 1:

	Rates	Fringes
POWER EQUIPMENT OPERATOR		
GROUP 1.....	\$ 35.91	22.45
GROUP 2.....	\$ 36.28	22.45
GROUP 3.....	\$ 36.99	22.45
GROUP 4.....	\$ 37.18	22.45
GROUP 5.....	\$ 37.37	22.45
GROUP 6.....	\$ 37.69	22.45
GROUP 7.....	\$ 38.01	22.45
GROUP 8.....	\$ 39.88	22.45

ZONE DIFFERENTIAL (Add to Zone 1 rate): Zone 2 - \$2.00

Zone 1: Within 45 mile radius of Spokane, Pasco, Washington; Lewiston, Idaho

Zone 2: Outside 45 mile radius of Spokane, Pasco, Washington; Lewiston, Idaho

POWER EQUIPMENT OPERATORS CLASSIFICATIONS

GROUP 1: Bit Grinders; Bolt Threading Machine; Compressors (under 2000 CFM, gas, diesel, or electric power); Deck Hand; Fireman & Heater Tender; Hydro-seeder, Mulcher, Nozzlemann; Oiler Driver, & Cable Tender, Mucking Machine; Pumpman; Rollers, all types on subgrade, including seal and chip coatings (farm type, Case, John Deere & similar, or Compacting Vibrator), except when pulled by Dozer with operable blade; Welding Machine; Crane Oiler-Driver (CLD required) & Cable Tender, Mucking Machine

GROUP 2: A-frame Truck (single drum); Assistant Refrigeration Plant (under 1000 ton); Assistant Plant Operator, Fireman or Pugmixer (asphalt); Bagley or Stationary Scraper; Belt Finishing Machine; Blower Operator (cement); Cement Hog; Compressor (2000 CFM or over, 2 or more, gas diesel or electric power); Concrete Saw (multiple cut); Distributor Leverman; Ditch Witch or similar; Elevator Hoisting Materials; Dope Pots (power agitated); Fork Lift or Lumber Stacker, hydra-lift & similar; Gin Trucks (pipeline); Hoist, single drum; Loaders (bucket elevators and conveyors); Longitudinal Float; Mixer (portable-concrete); Pavement Breaker, Hydra-Hammer & similar; Power Broom;

Railroad Ballast Regulation Operator (self-propelled); Railroad Power Tamper Operator (self-propelled); Railroad Tamper Jack Operator (self-propelled); Spray Curing Machine (concrete); Spreader Box (self-propelled); Straddle Buggy (Ross & similar on construction job only); Tractor (Farm type R/T with attachment, except Backhoe); Tugger Operator

GROUP 3: A-frame Truck (2 or more drums); Assistant Refrigeration Plant & Chiller Operator (over 1000 ton); Backfillers (Cleveland & similar); Batch Plant & Wet Mix Operator, single unit (concrete); Belt-Crete Conveyors with power pack or similar; Belt Loader (Kocal or similar); Bending Machine; Bob Cat (Skid Steer); Boring Machine (earth); Boring Machine (rock under 8 inch bit) (Quarry Master, Joy or similar); Bump Cutter (Wayne, Saginaw or similar); Canal Lining Machine (concrete); Chipper (without crane); Cleaning & Doping Machine (pipeline); Deck Engineer; Elevating Belt-type Loader (Euclid, Barber Green & similar); Elevating Grader-type Loader (Dumor, Adams or similar); Generator Plant Engineers (diesel or electric); Gunnite Combination Mixer & Compressor; Locomotive Engineer; Mixermobile; Mucking Machine; Posthole Auger or Punch; Pump (grout or jet); Soil Stabilizer (P & H or similar); Spreader Machine; Dozer/Tractor (up to D-6 or equivalent) and Traxcavator; Traverse Finish Machine; Turnhead Operator

GROUP 4: Concrete Pumps (squeeze-crete, flow-crete, pump-crete, Whitman & similar); Curb Extruder (asphalt or concrete); Drills (churn, core, calyx or diamond); Equipment Serviceman; Greaser & Oiler; Hoist (2 or more drums or Tower Hoist); Loaders (overhead & front-end, under 4 yds. R/T); Refrigeration Plant Engineer (under 1000 ton); Rubber-tired Skidders (R/T with or without attachments); Surface Heater & Plant Machine; Trenching Machines (under 7 ft. depth capacity); Turnhead (with re-screening); Vacuum Drill (reverse circulation drill under 8 inch bit)

GROUP 5: Backhoe (under 45,000 gw); Backhoe & Hoe Ram (under 3/4 yd.); Carrydeck & Boom Truck (under 25 tons); Cranes (25 tons & under), all attachments including clamshell, dragline; Derricks & Stifflegs (under 65 tons); Drilling Equipment (8 inch bit & over) (Robbins, reverse circulation & similar); Hoe Ram; Piledriving Engineers; Paving (dual drum); Railroad Track Liner Operator (self-propelled); Refrigeration Plant Engineer (1000 tons & over); Signalman (Whirleys, Highline Hammerheads or similar); Grade Checker

GROUP 6: Asphalt Plant Operator; Automatic Subgrader (Ditches & Trimmers)(Autograde, ABC, R.A. Hansen & similar on grade wire); Backhoe (45,000 gw and over to 110,000 gw); Backhoes & Hoe Ram (3/4 yd. to 3 yd.); Batch Plant (over 4 units); Batch & Wet Mix Operator (multiple units, 2 & incl. 4); Blade Operator (motor patrol & attachments); Cable Controller (dispatcher); Compactor (self-propelled with blade); Concrete Pump Boom Truck; Concrete Slip Form Paver; Cranes (over 25 tons, to and including 45 tons), all attachments including clamshell, dragline; Crusher, Grizzle & Screening Plant Operator; Dozer, 834 R/T & similar; Drill Doctor; Loader Operator (front-end & overhead, 4 yds. incl. 8 yds.); Multiple Dozer Units with single blade; Paving Machine (asphalt and concrete); Quad-Track or similar equipment; Roller (finishing asphalt pavement); Roto Mill (pavement grinder); Scrapers, all, rubber-tired; Screed Operator; Shovel (under 3 yds.); Trenching Machines (7 ft. depth & over); Tug Boat Operator Vector guzzler, super sucker; Lime Batch Tank Operator (REcycle Train); Lime Brain Operator (Recycle Train); Mobile Crusher Operator (Recycle Train)

GROUP 7: Backhoe (over 110,000 gw); Backhoes & Hoe Ram (3 yds & over); Blade (finish & bluetop) Automatic, CMI, ABC, Finish Athey & Huber & similar when used as automatic; Cableway Operators; Concrete Cleaning/Decontamination machine operator; Cranes (over 45 tons to but not including 85 tons), all attachments including clamshell and dragline; Derricks & Stiffleys (65 tons & over); Elevating Belt (Holland type); Heavy equipment robotics operator; Loader (360 degrees revolving Koehring Scooper or similar); Loaders (overhead & front-end, over 8 yds. to 10 yds.); Rubber-tired Scrapers (multiple engine with three or more scrapers); Shovels (3 yds. & over); Whirleys & Hammerheads, ALL; H.D. Mechanic; H.D. Welder; Hydraulic Platform Trailers (Goldhofer, Shaurerly and Similar); Ultra High Pressure Waterjet Cutting Tool System Operator (30,000 psi); Vacuum Blasting Machine Operator

GROUP 8: Cranes (85 tons and over, and all climbing, overhead, rail and tower), all attachments including clamshell, dragline; Loaders (overhead and front-end, 10 yards and over); Helicopter Pilot

BOOM PAY: (All Cranes, Including Tower)
 180 ft to 250 ft \$.50 over scale
 Over 250 ft \$.80 over scale

NOTE:
 In computing the length of the boom on Tower Cranes, they shall be measured from the base of the Tower to the point of the boom.

HAZMAT:
 Anyone working on HAZMAT jobs, working with supplied air shall receive \$1.00 an hour above classification.

 ENGI0612-001 06/01/2023

PIERCE County

ON PROJECTS DESCRIBED IN FOOTNOTE A BELOW, THE RATE FOR EACH GROUP SHALL BE 90% OF THE BASE RATE PLUS FULL FRINGE BENEFITS. ON ALL OTHER WORK, THE FOLLOWING RATES APPLY.

Zone 1 (0-25 radius miles):

	Rates	Fringes
POWER EQUIPMENT OPERATOR		
GROUP 1A.....	\$ 56.08	25.07
GROUP 1AA.....	\$ 56.89	25.07
GROUP 1AAA.....	\$ 57.70	25.07
GROUP 1.....	\$ 55.26	25.07
GROUP 2.....	\$ 54.55	25.07
GROUP 3.....	\$ 53.94	25.07
GROUP 4.....	\$ 50.50	25.07

Zone Differential (Add to Zone 1 rates):
 Zone 2 (26-45 radius miles) = \$1.00
 Zone 3 (Over 45 radius miles) - \$1.30

BASEPOINTS: CENTRALIA, OLYMPIA, TACOMA

POWER EQUIPMENT OPERATORS CLASSIFICATIONS

- GROUP 1 AAA - Cranes-over 300 tons or 300 ft of boom (including jib with attachments)
- GROUP 1AA - Cranes- 200 tonsto 300 tons, or 250 ft of boom

(including jib with attachments; Tower crane over 175 ft in height, bas to boom

GROUP 1A - Cranes, 100 tons thru 199 tons, or 150 ft of boom (including jib with attachments); Crane-overhead, bridge type, 100 tons and over; Tower crane up to 175 ft in height base to boom; Loaders-overhead, 8 yards and over; Shovels, excavator, backhoes-6 yards and over with attachments

GROUP 1 - Cableway; Cranes 45 tons thru 99 tons under 150 ft of boom (including jib with attachments); Crane-overhead, bridge type, 45 tons thru 99 tons; Derricks on building work; Excavator, shovel, backhoes over 3 yards and under 6 yards; Hard tail end dump articulating off-road equipment 45 yards and over; Loader- overhead, 6 yards to, but not including, 8 yards; Mucking machine, mole, tunnel, drill and/or shield; Quad 9 HD 41, D-10; Remote control operator on rubber tired earth moving equipment; Rollagon; Scrapers-self-propelled 45 yards and over; Slipform pavers; Transporters, all track or truck type

GROUP 2 - Barrier machine (zipper); Batch Plant Operator-concrete; Bump Cutter; Cranes, 20 tons thru 44 tons with attachments; Crane-Overhead, bridge type, 20 tons through 44 tons; Chipper; Concrete pump-truck mount with boom attachment; Crusher; Deck engineer/deck winches (power); Drilling machine; Excavator, shovel, backhoe-3 yards and under; Finishing machine, Bidwell, Gamaco and similar equipment; Guardrail punch; Loaders, overhead under 6 yards; Loaders-plant feed; Locomotives-all; Mechanics- all; Mixers, asphalt plant; Motor patrol graders, finishing; Piledriver (other than crane mount); Roto-mill, roto-grinder; Screedman, spreader, topside operator-Blaw Knox, Cedar Rapids, Jaeger, Caterpillar, Barbar Green; Scraper-self- propelled, hard tail end dump, articulating off-road equipment- under 45 yards; Subgrader trimmer; Tractors, backhoe over 75 hp; Transfer material service machine-shuttle buggy, Blaw Knox- Roadtec; Truck Crane oiler/driver-100 tons and over; Truck Mount Portable Conveyor; Yo Yo pay

GROUP 3 - Conveyors; Cranes through 19 tons with attachments; Crane-A-frame over 10 tons; Drill oilers-auger type, truck or crane mount; Dozer-D-9 and under; Forklift-3000 lbs. and over with attachments; Horizontal/directional drill locator; Outside Hoists-(elevators and manlifts), air tuggers, strato tower bucket elevators; Hydralifts/boom trucks over 10 tons; Loaders-elevating type, belt; Motor patrol grader-nonfinishing; Plant oiler- asphalt, crusher; Pump-Concrete; Roller, plant mix or multi-lfit materials; Saws-concrete; Scrapers, concrete and carry all; Service engineers-equipment; Trenching machines; Truck crane oiler/driver under 100 tons; Tractors, backhoe under 75 hp

GROUP 4 - Assistant Engineer; Bobcat; Brooms; Compressor; Concrete Finish Machine-laser screed; Cranes A-frame 10 tons and under; Elevator and manlift (permanent and shaft type); Forklifts-under 3000 lbs. with attachments; Gradechecker, stakeop; Hydralifts/boom trucks, 10 tons and under; Oil distributors, blower distribution and mulch seeding operator; Pavement breaker; Posthole digger-mechanical; Power plant; Pumps-water; Rigger and Bellman; Roller-other than plant mix; Wheel Tractors, farmall type; Shotcrete/gunite equipment operator

FOOTNOTE A- Reduced rates may be paid on the following:

1. Projects involving work on structures such as buildings and bridges whose total value is less than \$1.5 million excluding mechanical, electrical, and utility portions of the contract.

2. Projects of less than \$1 million where no building is involved. Surfacing and paving included, but utilities excluded.

3. Marine projects (docks, wharfs, etc.) less than \$150,000.

HANDLING OF HAZARDOUS WASTE MATERIALS: Personnel in all craft classifications subject to working inside a federally designated hazardous perimeter shall be eligible for compensation in accordance with the following group schedule relative to the level of hazardous waste as outlined in the specific hazardous waste project site safety plan.

H-1 Base wage rate when on a hazardous waste site when not outfitted with protective clothing, Class "D" Suit - Base wage rate plus \$.50 per hour.

H-2 Class "C" Suit - Base wage rate plus \$1.00 per hour.

H-3 Class "B" Suit - Base wage rate plus \$1.50 per hour.

H-4 Class "A" Suit - Base wage rate plus \$2.00 per hour.

ENGI0612-012 06/01/2023

LEWIS, PACIFIC (portion lying north of a parallel line extending west from the northern boundary of Wahkaikum County to the sea) AND THURSTON COUNTIES

ON PROJECTS DESCRIBED IN FOOTNOTE A BELOW, THE RATE FOR EACH GROUP SHALL BE 90% OF THE BASE RATE PLUS FULL FRINGE BENEFITS. ON ALL OTHER WORK, THE FOLLOWING RATES APPLY.

Zone 1 (0-25 radius miles):

	Rates	Fringes
POWER EQUIPMENT OPERATOR		
GROUP 1A.....	\$ 54.85	25.07
GROUP 1AA.....	\$ 55.67	25.07
GROUP 1AAA.....	\$ 56.45	25.07
GROUP 1.....	\$ 54.05	25.07
GROUP 2.....	\$ 53.36	25.07
GROUP 3.....	\$ 52.75	25.07
GROUP 4.....	\$ 49.36	25.07

Zone Differential (Add to Zone 1 rates):

Zone 2 (26-45 radius miles) = \$1.00

Zone 3 (Over 45 radius miles) - \$1.30

BASEPOINTS: CENTRALIA, OLYMPIA, TACOMA

POWER EQUIPMENT OPERATORS CLASSIFICATIONS

GROUP 1 AAA - Cranes-over 300 tons or 300 ft of boom (including jib with attachments)

GROUP 1AA - Cranes- 200 tonsto 300 tons, or 250 ft of boom (including jib with attachments; Tower crane over 175 ft in height, bas to boom

GROUP 1A - Cranes, 100 tons thru 199 tons, or 150 ft of boom (including jib with attachments); Crane-overhead, bridge type, 100 tons and over; Tower crane up to 175 ft in height base to boom; Loaders-overhead, 8 yards and over; Shovels, excavator, backhoes-6 yards and over with attachments

GROUP 1 - Cableway; Cranes 45 tons thru 99 tons under 150 ft

of boom (including jib with attachments); Crane-overhead, bridge type, 45 tons thru 99 tons; Derricks on building work; Excavator, shovel, backhoes over 3 yards and under 6 yards; Hard tail end dump articulating off-road equipment 45 yards and over; Loader- overhead, 6 yards to, but not including, 8 yards; Mucking machine, mole, tunnel, drill and/or shield; Quad 9 HD 41, D-10; Remote control operator on rubber tired earth moving equipment; Rollagon; Scrapers-self-propelled 45 yards and over; Slipform pavers; Transporters, all track or truck type

GROUP 2 - Barrier machine (zipper); Batch Plant Operator-concrete; Bump Cutter; Cranes, 20 tons thru 44 tons with attachments; Crane-Overhead, bridge type, 20 tons through 44 tons; Chipper; Concrete pump-truck mount with boom attachment; Crusher; Deck engineer/deck winches (power); Drilling machine; Excavator, shovel, backhoe-3 yards and under; Finishing machine, Bidwell, Gamaco and similar equipment; Guardrail punch; Loaders, overhead under 6 yards; Loaders-plant feed; Locomotives-all; Mechanics- all; Mixers, asphalt plant; Motor patrol graders, finishing; Piledriver (other than crane mount); Roto-mill, roto-grinder; Screedman, spreader, topside operator-Blaw Knox, Cedar Rapids, Jaeger, Caterpillar, Barbar Green; Scraper-self-propelled, hard tail end dump, articulating off-road equipment- under 45 yards; Subgrader trimmer; Tractors, backhoe over 75 hp; Transfer material service machine-shuttle buggy, Blaw Knox- Roadtec; Truck Crane oiler/driver-100 tons and over; Truck Mount Portable Conveyor; Yo Yo pay

GROUP 3 - Conveyors; Cranes through 19 tons with attachments; Crane-A-frame over 10 tons; Drill oilers-auger type, truck or crane mount; Dozer-D-9 and under; Forklift-3000 lbs. and over with attachments; Horizontal/directional drill locator; Outside Hoists-(elevators and manlifts), air tuggers, strato tower bucket elevators; Hydralifts/boom trucks over 10 tons; Loaders-elevating type, belt; Motor patrol grader-nonfinishing; Plant oiler- asphalt, crusher; Pump-Concrete; Roller, plant mix or multi-lfit materials; Saws-concrete; Scrapers, concrete and carry all; Service engineers-equipment; Trenching machines; Truck crane oiler/driver under 100 tons; Tractors, backhoe under 75 hp

GROUP 4 - Assistant Engineer; Bobcat; Brooms; Compressor; Concrete Finish Machine-laser screed; Cranes A-frame 10 tons and under; Elevator and manlift (permanent and shaft type); Forklifts-under 3000 lbs. with attachments; Gradechecker, stakehop; Hydralifts/boom trucks, 10 tons and under; Oil distributors, blower distribution and mulch seeding operator; Pavement breaker; Posthole digger-mechanical; Power plant; Pumps-water; Rigger and Bellman; Roller-other than plant mix; Wheel Tractors, farmall type; Shotcrete/gunite equipment operator

- FOOTNOTE A- Reduced rates may be paid on the following:
1. Projects involving work on structures such as buildings and bridges whose total value is less than \$1.5 million excluding mechanical, electrical, and utility portions of the contract.
 2. Projects of less than \$1 million where no building is involved. Surfacing and paving included, but utilities excluded.
 3. Marine projects (docks, wharfs, etc.) less than \$150,000.

HANDLING OF HAZARDOUS WASTE MATERIALS: Personnel in all craft classifications subject to working inside a federally

designated hazardous perimeter shall be eligible for compensation in accordance with the following group schedule relative to the level of hazardous waste as outlined in the specific hazardous waste project site safety plan.

H-1 Base wage rate when on a hazardous waste site when not outfitted with protective clothing, Class "D" Suit - Base wage rate plus \$.50 per hour.

H-2 Class "C" Suit - Base wage rate plus \$1.00 per hour.

H-3 Class "B" Suit - Base wage rate plus \$1.50 per hour.

H-4 Class "A" Suit - Base wage rate plus \$2.00 per hour.

ENGI0701-002 01/01/2022

CLARK, COWLITZ, KLICKITAT, PACIFIC (SOUTH), SKAMANIA, AND WAHKIAKUM COUNTIES

POWER EQUIPMENT OPERATORS: ZONE 1

	Rates	Fringes
POWER EQUIPMENT OPERATOR		
GROUP 1.....	\$ 51.65	16.35
GROUP 1A.....	\$ 53.81	16.35
GROUP 1B.....	\$ 55.97	16.35
GROUP 2.....	\$ 49.74	16.35
GROUP 3.....	\$ 48.59	16.35
GROUP 4.....	\$ 45.26	16.35
GROUP 5.....	\$ 44.02	16.35
GROUP 6.....	\$ 40.80	16.35

Zone Differential (add to Zone 1 rates):

Zone 2 - \$3.00

Zone 3 - \$6.00

For the following metropolitan counties: MULTNOMAH; CLACKAMAS; MARION; WASHINGTON; YAMHILL; AND COLUMBIA; CLARK; AND COWLITZ COUNTY, WASHINGTON WITH MODIFICATIONS AS INDICATED:

All jobs or projects located in Multnomah, Clackamas and Marion Counties, West of the western boundary of Mt. Hood National Forest and West of Mile Post 30 on Interstate 84 and West of Mile Post 30 on State Highway 26 and West of Mile Post 30 on Highway 22 and all jobs or projects located in Yamhill County, Washington County and Columbia County and all jobs or projects located in Clark & Cowlitz County, Washington except that portion of Cowlitz County in the Mt. St. Helens "Blast Zone" shall receive Zone I pay for all classifications.

All jobs or projects located in the area outside the identified boundary above, but less than 50 miles from the Portland City Hall shall receive Zone II pay for all classifications.

All jobs or projects located more than 50 miles from the Portland City Hall, but outside the identified border above, shall receive Zone III pay for all classifications.

For the following cities: ALBANY; BEND; COOS BAY; EUGENE; GRANTS PASS; KLAMATH FALLS; MEDFORD; ROSEBURG

All jobs or projects located within 30 miles of the respective city hall of the above mentioned cities shall receive Zone I pay for all classifications.

All jobs or projects located more than 30 miles and less than 50 miles from the respective city hall of the above mentioned cities shall receive Zone II pay for all classifications.

All jobs or projects located more than 50 miles from the respective city hall of the above mentioned cities shall receive Zone III pay for all classifications.

POWER EQUIPMENT OPERATORS CLASSIFICATIONS

Group 1

Concrete Batch Plan and or Wet mix three (3) units or more; Crane, Floating one hundred and fifty (150) ton but less than two hundred and fifty (250) ton; Crane, two hundred (200) ton through two hundred ninety nine (299) ton with two hundred foot (200') boom or less (including jib, inserts and/or attachments); Crane, ninety (90) ton through one hundred ninety nine (199) ton with over two hundred (200') boom Including jib, inserts and/or attachments); Crane, Tower Crane with one hundred seventy five foot (175') tower or less and with less than two hundred foot (200') jib; Crane, Whirley ninety (90) ton and over; Helicopter when used in erecting work

Group 1A

Crane, floating two hundred fifty (250) ton and over; Crane, two hundred (200) ton through two hundred ninety nine (299) ton, with over two hundred foot (200') boom (including jib, inserts and/or attachments); Crane, three hundred (300) ton through three hundred ninety nine (399) ton; Crane, Tower Crane with over one hundred seventy five foot (175') tower or over two hundred foot (200') jib; Crane, tower Crane on rail system or 2nd tower or more in work radius

Group 1B

Crane, three hundred (300) ton through three hundred ninety nine (399) ton, with over two hundred foot (200') boom (including jib, inserts and/or attachments); Floating crane, three hundred fifty (350) ton and over; Crane, four hundred (400) ton and over

Group 2

Asphalt Plant (any type); Asphalt Roto-Mill, pavement profiler eight foot (8') lateral cut and over; Auto Grader or "Trimmer"; Blade, Robotic; Bulldozer, Robotic Equipment (any type); Bulldozer, over one hundred twenty thousand (120,000) lbs. and above; Concrete Batch Plant and/or Wet Mix one (1) and two (2) drum; Concrete Diamond Head Profiler; Canal Trimmer; Concrete, Automatic Slip Form Paver (Assistant to the Operator required); Crane, Boom Truck fifty (50) ton and with over one hundred fifty foot (150') boom and over; Crane, Floating (derrick barge) thirty (30) ton but less than one hundred fifty (150) ton; Crane, Cableway twenty-five (25) ton and over; Crane, Floating Clamshell three (3) cu. Yds. And over; Crane, ninety (90) ton through one hundred ninety nine (199) ton up to and including two hundred foot (200') of boom (including jib inserts and/or attachments); Crane, fifty (50) ton through eighty nine (89) ton with over one hundred fifty foot (150') boom (including jib inserts and/or attachments); Crane, Whirley under ninety (90) ton; Crusher Plant; Excavator over one hundred thirty thousand (130,000) lbs.; Loader one hundred twenty thousand (120,000) lbs. and above; Remote Controlled Earth Moving Equipment; Shovel, Dragline, Clamshell, five (5) cu. Yds. And over; Underwater Equipment remote or otherwise, when used in construction work; Wheel Excavator any size

Group 3

Bulldozer, over seventy thousand (70,000) lbs. up to and including one hundred twenty thousand (120,000) lbs.; Crane, Boom Truck fifty (50) ton and over with less than one hundred fifty foot (150') boom; Crane, fifty (50) ton through eighty nine (89) ton with one hundred fifty foot (150') boom or less (including jib inserts and/or attachments); Crane, Shovel, Dragline or Clamshell three (3) cu. yds. but less than five (5) cu. Yds.; Excavator over eighty thousand (80,000) lbs. through one hundred thirty thousand (130,000) lbs.; Loader sixty thousand (60,000) lbs. and less than one hundred twenty thousand (120,000) lbs.

Group 4

Asphalt, Screed; Asphalt Paver; Asphalt Roto-Mill, pavement profiler, under eight foot (8') lateral cut; Asphalt, Material Transfer Vehicle Operator; Back Filling Machine; Backhoe, Robotic, track and wheel type up to and including twenty thousand (20,000) lbs. with any attachments; Blade (any type); Boatman; Boring Machine; Bulldozer over twenty thousand (20,000) lbs. and more than one hundred (100) horse up to seventy thousand (70,000) lbs.; Cable-Plow (any type); Cableway up to twenty five (25) ton; Cat Drill (John Henry); Chippers; Compactor, multi-engine; Compactor, Robotic; Compactor with blade self-propelled; Concrete, Breaker; Concrete, Grout Plant; Concrete, Mixer Mobile; Concrete, Paving Road Mixer; Concrete, Reinforced Tank Banding Machine; Crane, Boom Truck twenty (20) ton and under fifty (50) ton; Crane, Bridge Locomotive, Gantry and Overhead; Crane, Carry Deck; Crane, Chicago Boom and similar types; Crane, Derrick Operator, under one hundred (100) ton; Crane, Floating Clamshell, Dragline, etc. Operator, under three (3) cu. yds. Or less than thirty (30) ton; Crane, under fifty (50) ton; Crane, Quick Tower under one hundred foot (100') in height and less than one hundred fifty foot (150') jib (on rail included); Diesel-Electric Engineer (Plant or Floating); Directional Drill over twenty thousand (20,000) lbs. pullback; Drill Cat Operator; Drill Doctor and/or Bit Grinder; Driller, Percussion, Diamond, Core, Cable, Rotary and similar type; Excavator Operator over twenty thousand (20,000) lbs. through eighty thousand (80,000) lbs.; Generator Operator; Grade-all; Guardrail Machines, i.e. punch, auger, etc.; Hammer Operator (Piledriver); Hoist, stiff leg, guy derrick or similar type, fifty (50) ton and over; Hoist, two (2) drums or more; Hydro Axe (loader mounted or similar type); Jack Operator, Elevating Barges, Barge Operator, self-unloading; Loader Operator, front end and overhead, twenty five thousand (25,000) lbs. and less than sixty thousand (60,000) lbs.; Log Skidders; Piledriver Operator (not crane type); Pipe, Bending, Cleaning, Doping and Wrapping Machines; Rail, Ballast Tamper Multi-Purpose; Rubber-tired Dozers and Pushers; Scraper, all types; Side-Boom; Skip Loader, Drag Box; Strump Grinder (loader mounted or similar type); Surface Heater and Planer; Tractor, rubber-tired, over fifty (50) HP Flywheel; Trenching Machine three foot (3') depth and deeper; Tub Grinder (used for wood debris); Tunnel Boring Machine Mechanic; Tunnel, Mucking Machine; Ultra High Pressure Water Jet Cutting Tool System Operator; Vacuum Blasting Machine Operator; Water pulls, Water wagons

Group 5

Asphalt, Extrusion Machine; Asphalt, Roller (any asphalt mix); Asphalt, Roto-Mill pavement profiler ground man; Bulldozer, twenty thousand (20,000) lbs. or less, or one hundred (100) horse or less; Cement Pump; Chip Spreading

Machine; Churn Drill and Earth Boring Machine; Compactor, self-propelled without blade; Compressor, (any power) one thousand two hundred fifty (1,250) cu. ft. and over, total capacity; Concrete, Batch Plant Quality control; Concrete, Combination Mixer and compressor operator, gunite work; Concrete, Curb Machine, Mechanical Berm, Curb and/or Curb and Gutter; Concrete, Finishing Machine; Concrete, Grouting Machine; Concrete, Internal Full Slab Vibrator Operator; Concrete, Joint Machine; Concrete, Mixer single drum, any capacity; Concrete, Paving Machine eight foot (8') or less; Concrete, Planer; Concrete, Pump; Concrete, Pump Truck; Concrete, Pumpcrete Operator (any type); Concrete, Slip Form Pumps, power driven hydraulic lifting device for concrete forms; Conveyored Material Hauler; Crane, Boom Truck under twenty (20) tons; Crane, Boom Type lifting device, five (5) ton capacity or less; Drill, Directional type less than twenty thousand (20,000) lbs. pullback; Fork Lift, over ten (10) ton or Robotic; Helicopter Hoist; Hoist Operator, single drum; Hydraulic Backhoe track type up to and including twenty thousand (20,000) lbs.; Hydraulic Backhoe wheel type (any make); Laser Screed; Loaders, rubber-tired type, less than twenty five thousand (25,000) lbs.; Pavement Grinder and/or Grooving Machine (riding type); Pipe, cast in place Pipe Laying Machine; Pulva-Mixer or similar types; Pump Operator, more than five (5) pumps (any size); Rail, Ballast Compactor, Regulator, or Tamper machines; Service Oiler (Greaser); Sweeper Self-Propelled; Tractor, Rubber-Tired, fifty (50) HP flywheel and under; Trenching Machine Operator, maximum digging capacity three foot (3') depth; Tunnel, Locomotive, Dinkey; Tunnel, Power Jumbo setting slip forms, etc.

Group 6

Asphalt, Pugmill (any type); Asphalt, Raker; Asphalt, Truck Mounted Asphalt Spreader, with Screed; Auger Oiler; Boatman; Bobcat, skid steed (less than one (1) yard); Broom, self-propelled; Compressor Operator (any power) under 1,250 cu. ft. total capacity; Concrete Curing Machine (riding type); Concrete Saw; Conveyor Operator or Assistant; Crane, Tugger; Crusher Feederman; Crusher Oiler; Deckhand; Drill, Directional Locator; Fork Lift; Grade Checker; Guardrail Punch Oiler; Hydrographic Seeder Machine, straw, pulp or seed; Hydrostatic Pump Operator; Mixer Box (CTB, dry batch, etc.); Oiler; Plant Oiler; Pump (any power); Rail, Brakeman, Switchman, Motorman; Rail, Tamping Machine, mechanical, self-propelled; Rigger; Roller grading (not asphalt); Truck, Crane Oiler-Driver

 * IRON0014-005 01/01/2024

ADAMS, ASOTIN, BENTON, COLUMBIA, DOUGLAS, FERRY, FRANKLIN, GARFIELD, GRANT, LINCOLN, OKANOGAN, PEND ORIELLE, SPOKANE, STEVENS, WALLA WALLA AND WHITMAN COUNTIES

	Rates	Fringes
IRONWORKER.....	\$ 38.91	32.27

 IRON0029-002 01/02/2023

CLARK, COWLITZ, KLICKITAT, PACIFIC, SKAMANIA, AND WAHKAIKUM COUNTIES

	Rates	Fringes
IRONWORKER.....	\$ 42.27	32.57

* IRON0086-002 01/01/2024

YAKIMA, KITTITAS AND CHELAN COUNTIES

	Rates	Fringes
IRONWORKER.....	\$ 38.91	32.27

* IRON0086-004 01/01/2024

CLALLAM, GRAYS HARBOR, ISLAND, JEFFERSON, KING, KITSAP, LEWIS, MASON, PIERCE, SKAGIT, SNOHOMISH, THURSTON, AND WHATCOM COUNTIES

	Rates	Fringes
IRONWORKER.....	\$ 53.45	34.02

LABO0238-004 06/01/2023

A-1 AREA: ASOTIN, BENTON, FRANKLIN, GARFIELD, LINCOLN, SPOKANE, WALLA WALLA, & WHITMAN COUNTIES

A-2 AREA: ADAMS, COLUMBIA, DOUGLAS (East of 120th Meridian), FERRY, GRANT, OKANOGAN, PEND OREILLE, & STEVENS COUNTIES

	Rates	Fringes
LABORER (A-1)		
GROUP 1.....	\$ 30.88	15.70
GROUP 2.....	\$ 33.72	15.70
GROUP 3.....	\$ 34.03	15.70
GROUP 4.....	\$ 34.33	15.70
GROUP 5.....	\$ 34.64	15.70
LABORER (A-2)		
GROUP 1.....	\$ 33.88	15.60
GROUP 2.....	\$ 36.72	15.60
GROUP 3.....	\$ 37.03	15.60
GROUP 4.....	\$ 37.33	15.60
GROUP 5.....	\$ 37.64	15.60

LABORERS CLASSIFICATIONS

GROUP 1: Flagman; Landscape Laborer; Scaleman; Traffic Control Maintenance Laborer (to include erection and maintenance of barricades, signs and relief of flagperson); Window Washer/Cleaner (detail cleanup, such as, but not limited to cleaning floors, ceilings, walls, windows, etc. prior to final acceptance by the owner)

GROUP 2: Asbestos Abatement Worker; Brush Hog Feeder; Carpenter Tender; Cement Handler; Clean-up Laborer; Concrete Crewman (to include stripping of forms, hand operating jacks on slip form construction, application of concrete curing compounds, pumpcrete machine, signaling, handling the nozzle of squeezcrete or similar machine, 6 inches and smaller); Confined Space Attendant; Concrete Signalman; Crusher Feeder; Demolition (to include clean-up, burning, loading, wrecking and salvage of all material); Dumpman; Fence Erector; Firewatch; Form Cleaning Machine Feeder, Stacker; General Laborer; Grout Machine Header Tender; Guard Rail (to include guard rails, guide and reference posts, sign posts, and right-of-way markers); Hazardous Waste Worker, Level D (no respirator is used and skin protection is minimal); Miner, Class "A" (to include all bull gang, concrete crewman, dumpman and pumpcrete crewman, including distributing pipe, assembly & dismantle, and nipper); Nipper; Riprap Man; Sandblast Tailhoseman;

Scaffold Erector (wood or steel); Stake Jumper; Structural Mover (to include separating foundation, preparation, cribbing, shoring, jacking and unloading of structures); Tailhoseman (water nozzle); Timber Bucker and Faller (by hand); Track Laborer (RR); Truck Loader; Well-Point Man; All Other Work Classifications Not Specially Listed Shall Be Classified As General Laborer

GROUP 3: Asphalt Roller, walking; Cement Finisher Tender; Concrete Saw, walking; Demolition Torch; Dope Pot Firemen, non-mechanical; Driller Tender (when required to move and position machine); Form Setter, Paving; Grade Checker using level; Hazardous Waste Worker, Level C (uses a chemical "splash suit" and air purifying respirator); Jackhammer Operator; Miner, Class "B" (to include brakeman, finisher, vibrator, form setter); Nozzleman (to include squeeze and flo-crete nozzle); Nozzleman, water, air or steam; Pavement Breaker (under 90 lbs.); Pipelayer, corrugated metal culvert; Pipelayer, multi-plate; Pot Tender; Power Buggy Operator; Power Tool Operator, gas, electric, pneumatic; Railroad Equipment, power driven, except dual mobile power spiker or puller; Railroad Power Spiker or Puller, dual mobile; Rodder and Spreader; Tamper (to include operation of Barco, Essex and similar tampers); Trencher, Shawnee; Tugger Operator; Wagon Drills; Water Pipe Liner; Wheelbarrow (power driven)

GROUP 4: Air and Hydraulic Track Drill; Asphalt Raker; Brush Machine (to include horizontal construction joint cleanup brush machine, power propelled); Caisson Worker, free air; Chain Saw Operator and Faller; Concrete Stack (to include laborers when laborers working on free standing concrete stacks for smoke or fume control above 40 feet high); Guniting (to include operation of machine and nozzle); Hazardous Waste Worker, Level B (uses same respirator protection as Level A. A supplied air line is provided in conjunction with a chemical "splash suit"); High Scaler; Laser Beam Operator (to include grade checker and elevation control); Miner, Class C (to include miner, nozzleman for concrete, laser beam operator and rigger on tunnels); Monitor Operator (air track or similar mounting); Mortar Mixer; Nozzleman (to include jet blasting nozzleman, over 1,200 lbs., jet blast machine power propelled, sandblast nozzle); Pavement Breaker (90 lbs. and over); Pipelayer (to include working topman, caulker, collarman, jointer, mortarman, rigger, jacker, shorer, valve or meter installer); Pipewrapper; Plasterer Tender; Vibrators (all)

GROUP 5 - Drills with Dual Masts; Hazardous Waste Worker, Level A (utilizes a fully encapsulated suit with a self-contained breathing apparatus or a supplied air line); Miner Class "D", (to include raise and shaft miner, laser beam operator on riases and shafts)

LAB00238-006 06/01/2023

COUNTIES EAST OF THE 120TH MERIDIAN: ADAMS, ASOTIN, BENTON, CHELAN, COLUMBIA, DOUGLAS, FERRY, FRANKLIN, GARFIELD, GRANT, LINCOLN, OKANOGAN, PEND OREILLE, STEVENS, SPOKANE, WALLA WALLA, WHITMAN

	Rates	Fringes
Hod Carrier.....	\$ 34.97	15.70

LAB00242-003 06/01/2022

KING COUNTY

Rates Fringes

LABORER

GROUP 1.....	\$ 29.82	13.80
GROUP 2A.....	\$ 34.20	13.80
GROUP 3.....	\$ 42.86	13.80
GROUP 4.....	\$ 43.90	13.80
GROUP 5.....	\$ 44.62	13.80
Group 6.....	\$ 45.91	13.90

BASE POINTS: BELLINGHAM, MT. VERNON, EVERETT, SEATTLE, KENT, TACOMA, OLYMPIA, CENTRALIA, ABERDEEN, SHELTON, PT. TOWNSEND, PT. ANGELES, AND BREMERTON

- ZONE 1 - Projects within 25 radius miles of the respective city hall
- ZONE 2 - More than 25 but less than 45 radius miles from the respective city hall
- ZONE 3 - More than 45 radius miles from the respective city hall

ZONE DIFFERENTIAL (ADD TO ZONE 1 RATES):
 ZONE 2 - \$1.00
 ZONE 3 - \$1.30

BASE POINTS: CHELAN, SUNNYSIDE, WENATCHEE, AND YAKIMA

- ZONE 1 - Projects within 25 radius miles of the respective city hall
- ZONE 2 - More than 25 radius miles from the respective city hall

ZONE DIFFERENTIAL (ADD TO ZONE 1 RATES):
 ZONE 2 - \$2.25

LABORERS CLASSIFICATIONS

GROUP 1: Landscaping and Planting; Watchman; Window Washer/Cleaner (detail clean-up, such as but not limited to cleaning floors, ceilings, walls, windows, etc., prior to final acceptance by the owner)

GROUP 2A: Batch Weighman; Crusher Feeder; Fence Laborer; Flagman; Pilot Car

GROUP 3: General Laborer; Air, Gas, or Electric Vibrating Screed; Asbestos Abatement Laborer; Ballast Regulator Machine; Brush Cutter; Brush Hog Feeder; Burner; Carpenter Tender; Cement Finisher Tender; Change House or Dry Shack; Chipping Gun (under 30 lbs.); Choker Setter; Chuck Tender; Clean-up Laborer; Concrete Form Stripper; Curing Laborer; Demolition (wrecking and moving including charred material); Ditch Digger; Dump Person; Fine Graders; Firewatch; Form Setter; Gabian Basket Builders; Grout Machine Tender; Grinders; Guardrail Erector; Hazardous Waste Worker (Level C: uses a chemical "splash suit" and air purifying respirator); Maintenance Person; Material Yard Person; Pot Tender; Rip Rap Person; Riggers; Scale Person; Sloper Sprayer; Signal Person; Stock Piler; Stake Hopper; Toolroom Man (at job site); Topper-Tailer; Track Laborer; Truck Spotter; Vinyl Seamer

GROUP 4: Cement Dumper-Paving; Chipping Gun (over 30 lbs.); Clary Power Spreader; Concrete Dumper/Chute Operator; Concrete Saw Operator; Drill Operator (hydraulic, diamond, aiartrac); Faller and Bucker Chain Saw; Grade Checker and Transit Person; Groutmen (pressure) including post tension beams; Hazardous Waste Worker (Level B: uses same respirator protection as Level A. A supplied air line is

provided in conjunction with a chemical ""splash suit""); High Scaler; Jackhammer; Laserbeam Operator; Manhole Builder-Mudman; Nozzleman (concrete pump, green cutter when using combination of high pressure air and water on concrete and rock, sandblast, gunite, shotcrete, water blaster, vacuum blaster); Pavement Breaker; Pipe Layer and Caulker; Pipe Pot Tender; Pipe Reliner (not insert type); Pipe Wrapper; Power Jacks; Railroad Spike Puller-Power; Raker-Asphalt; Rivet Buster; Rodder; Sloper (over 20 ft); Spreader (concrete); Tamper and Similar electric, air and glas operated tool; Timber Person-sewer (lagger shorer and cribber); Track Liner Power; Tugger Operator; Vibrator; Well Point Laborer

GROUP 5: Caisson Worker; Mortarman and Hodcarrier; Powderman; Re-Timberman; Hazardous Waste Worker (Level A: utilizes a fully encapsulated suit with a self-contained breathing apparatus or a supplied air line).

Group 6: Miner

LABO0252-010 06/01/2022

CLALLAM, GRAYS HARBOR, JEFFERSON, KITSAP, LEWIS, MASON, PACIFIC (EXCLUDING SOUTHWEST), PIERCE, AND THURSTON COUNTIES

	Rates	Fringes
LABORER		
GROUP 1.....	\$ 29.82	13.80
GROUP 2.....	\$ 34.20	13.80
GROUP 3.....	\$ 42.86	13.80
GROUP 4.....	\$ 43.90	13.80
GROUP 5.....	\$ 44.62	13.80

BASE POINTS: BELLINGHAM, MT. VERNON, EVERETT, SEATTLE, KENT, TACOMA, OLYMPIA, CENTRALIA, ABERDEEN, SHELTON, PT. TOWNSEND, PT. ANGELES, AND BREMERTON

- ZONE 1 - Projects within 25 radius miles of the respective city hall
- ZONE 2 - More than 25 but less than 45 radius miles from the respective city hall
- ZONE 3 - More than 45 radius miles from the respective city hall

ZONE DIFFERENTIAL (ADD TO ZONE 1 RATES):
 ZONE 2 - \$1.00
 ZONE 3 - \$1.30

BASE POINTS: CHELAN, SUNNYSIDE, WENATCHEE, AND YAKIMA

- ZONE 1 - Projects within 25 radius miles of the respective city hall
- ZONE 2 - More than 25 radius miles from the respective city hall

ZONE DIFFERENTIAL (ADD TO ZONE 1 RATES):
 ZONE 2 - \$2.25

LABORERS CLASSIFICATIONS

GROUP 1: Landscaping and Planting; Watchman; Window Washer/Cleaner (detail clean-up, such as but not limited to cleaning floors, ceilings, walls, windows, etc., prior to final acceptance by the owner)

GROUP 2: Batch Weighman; Crusher Feeder; Fence Laborer;

Flagman; Pilot Car

GROUP 3: General Laborer; Air, Gas, or Electric Vibrating Screed; Asbestos Abatement Laborer; Ballast Regulator Machine; Brush Cutter; Brush Hog Feeder; Burner; Carpenter Tender; Cement Finisher Tender; Change House or Dry Shack; Chipping Gun (under 30 lbs.); Choker Setter; Chuck Tender; Clean-up Laborer; Concrete Form Stripper; Curing Laborer; Demolition (wrecking and moving including charred material); Ditch Digger; Dump Person; Fine Graders; Firewatch; Form Setter; Gabian Basket Builders; Grout Machine Tender; Grinders; Guardrail Erector; Hazardous Waste Worker (Level C: uses a chemical "splash suit" and air purifying respirator); Maintenance Person; Material Yard Person; Pot Tender; Rip Rap Person; Riggers; Scale Person; Sloper Sprayer; Signal Person; Stock Piler; Stake Hopper; Toolroom Man (at job site); Topper-Tailer; Track Laborer; Truck Spotter; Vinyl Seamer

GROUP 4: Cement Dumper-Paving; Chipping Gun (over 30 lbs.); Clary Power Spreader; Concrete Dumper/Chute Operator; Concrete Saw Operator; Drill Operator (hydraulic, diamond, airtrac); Faller and Bucker Chain Saw; Groutmen (pressure) including post tension beams; Hazardous Waste Worker (Level B: uses same respirator protection as Level A. A supplied air line is provided in conjunction with a chemical "splash suit"); Jackhammer; Laserbeam Operator; Manhole Builder-Mudman; Nozzleman (concrete pump, green cutter when using combination of high pressure air and water on concrete and rock, sandblast, gunite, shotcrete, water blaster, vacuum blaster); Pavement Breaker; Pipe Layer and Caulker; Pipe Pot Tender; Pipe Reliner (not insert type); Pipe Wrapper; Power Jacks; Railroad Spike Puller-Power; Raker-Asphalt; Rivet Buster; Rodder; Sloper (over 20 ft); Spreader (concrete); Tamper and Similar electric, air and glas operated tool; Timber Person-sewer (lagger shorer and cribber); Track Liner Power; Tugger Operator; Vibrator; Well Point Laborer

GROUP 5: Caisson Worker; Miner; Mortarman and Hodcarrier; Grade Checker and Transit Person; High Scaler; Powderman; Re-Timberman; Hazardous Waste Worker (Level A: utilizes a fully encapsulated suit with a self-contained breathing apparatus or a supplied air line).

LAB00292-008 06/01/2022

ISLAND, SAN JUAN, SKAGIT, SNOHOMISH, AND WHATCOM COUNTIES

Rates Fringes

LABORER

GROUP 1.....	\$ 29.82	13.80
GROUP 2.....	\$ 34.20	13.80
GROUP 3.....	\$ 42.86	13.80
GROUP 4.....	\$ 43.90	13.80
GROUP 5.....	\$ 44.62	13.80

BASE POINTS: BELLINGHAM, MT. VERNON, EVERETT, SEATTLE, KENT, TACOMA, OLYMPIA, CENTRALIA, ABERDEEN, SHELTON, PT. TOWNSEND, PT. ANGELES, AND BREMERTON

ZONE 1 - Projects within 25 radius miles of the respective city hall
ZONE 2 - More than 25 but less than 45 radius miles from the respective city hall
ZONE 3 - More than 45 radius miles from the respective city hall

ZONE DIFFERENTIAL (ADD TO ZONE 1 RATES):

ZONE 2 - \$1.00

ZONE 3 - \$1.30

BASE POINTS: CHELAN, SUNNYSIDE, WENATCHEE, AND YAKIMA

ZONE 1 - Projects within 25 radius miles of the respective city hall

ZONE 2 - More than 25 radius miles from the respective city hall

ZONE DIFFERENTIAL (ADD TO ZONE 1 RATES):

ZONE 2 - \$2.25

LABORERS CLASSIFICATIONS

GROUP 1: Landscaping and Planting; Watchman; Window Washer/Cleaner (detail clean-up, such as but not limited to cleaning floors, ceilings, walls, windows, etc., prior to final acceptance by the owner)

GROUP 2: Batch Weighman; Crusher Feeder; Fence Laborer; Flagman; Pilot Car

GROUP 3: General Laborer; Air, Gas, or Electric Vibrating Screed; Asbestos Abatement Laborer; Ballast Regulator Machine; Brush Cutter; Brush Hog Feeder; Burner; Carpenter Tender; Cement Finisher Tender; Change House or Dry Shack; Chipping Gun (under 30 lbs.); Choker Setter; Chuck Tender; Clean-up Laborer; Concrete Form Stripper; Curing Laborer; Demolition (wrecking and moving including charred material); Ditch Digger; Dump Person; Fine Graders; Firewatch; Form Setter; Gabian Basket Builders; Grout Machine Tender; Grinders; Guardrail Erector; Hazardous Waste Worker (Level C: uses a chemical "splash suit" and air purifying respirator); Maintenance Person; Material Yard Person; Pot Tender; Rip Rap Person; Riggers; Scale Person; Sloper Sprayer; Signal Person; Stock Piler; Stake Hopper; Toolroom Man (at job site); Topper-Tailer; Track Laborer; Truck Spotter; Vinyl Seamer

GROUP 4: Cement Dumper-Paving; Chipping Gun (over 30 lbs.); Clary Power Spreader; Concrete Dumper/Chute Operator; Concrete Saw Operator; Drill Operator (hydraulic, diamond, airtrac); Faller and Bucker Chain Saw; Grade Checker and Transit Person; Groutmen (pressure) including post tension beams; Hazardous Waste Worker (Level B: uses same respirator protection as Level A. A supplied air line is provided in conjunction with a chemical "splash suit"); High Scaler; Jackhammer; Laserbeam Operator; Manhole Builder-Mudman; Nozzleman (concrete pump, green cutter when using combination of high pressure air and water on concrete and rock, sandblast, gunite, shotcrete, water blaster, vacuum blaster); Pavement Breaker; Pipe Layer and Caulker; Pipe Pot Tender; Pipe Reliner (not insert type); Pipe Wrapper; Power Jacks; Railroad Spike Puller-Power; Raker-Asphalt; Rivet Buster; Rodder; Sloper (over 20 ft); Spreader (concrete); Tamper and Similar electric, air and gas operated tool; Timber Person-sewer (lagger shorer and cribber); Track Liner Power; Tugger Operator; Vibrator; Well Point Laborer

GROUP 5: Caisson Worker; Miner; Mortarman and Hodcarrier; Powderman; Re-Timberman; Hazardous Waste Worker (Level A: utilizes a fully encapsulated suit with a self-contained breathing apparatus or a supplied air line).

CLARK, COWLITZ, KLUCKITAT, PACIFIC (SOUTH OF A STRAIGHT LINE MADE BY EXTENDING THE NORTH BOUNDARY LINE OF WAHKIAKUM COUNTY WEST TO THE PACIFIC OCEAN), SKAMANIA AND WAHKIAKUM COUNTIES

Rates Fringes

Laborers:

ZONE 1:		
GROUP 1.....	\$ 37.98	13.80
GROUP 2.....	\$ 38.76	13.80
GROUP 3.....	\$ 39.35	13.80
GROUP 4.....	\$ 39.85	13.80
GROUP 5.....	\$ 34.75	13.80
GROUP 6.....	\$ 31.61	13.80
GROUP 7.....	\$ 27.44	13.80

Zone Differential (Add to Zone 1 rates):

Zone 2 \$ 0.65
 Zone 3 - 1.15
 Zone 4 - 1.70
 Zone 5 - 2.75

BASE POINTS: LONGVIEW AND VANCOUVER

ZONE 1: Projects within 30 miles of the respective city all.
 ZONE 2: More than 30 miles but less than 40 miles from the respective city hall.
 ZONE 3: More than 40 miles but less than 50 miles from the respective city hall.
 ZONE 4: More than 50 miles but less than 80 miles from the respective city hall.
 ZONE 5: More than 80 miles from the respective city hall.

LABORERS CLASSIFICATIONS

GROUP 1: Asphalt Plant Laborers; Asphalt Spreaders; Batch Weighman; Broomers; Brush Burners and Cutters; Car and Truck Loaders; Carpenter Tender; Change-House Man or Dry Shack Man; Choker Setter; Clean-up Laborers; Curing, Concrete; Demolition, Wrecking and Moving Laborers; Dumpers, road oiling crew; Dumpmen (for grading crew); Elevator Feeders; Median Rail Reference Post, Guide Post, Right of Way Marker; Fine Graders; Fire Watch; Form Strippers (not swinging stages); General Laborers; Hazardous Waste Worker; Leverman or Aggregate Spreader (Flaherty and similar types); Loading Spotters; Material Yard Man (including electrical); Pittsburgh Chipper Operator or Similar Types; Railroad Track Laborers; Ribbon Setters (including steel forms); Rip Rap Man (hand placed); Road Pump Tender; Sewer Labor; Signalman; Skipman; Slopers; Spraymen; Stake Chaser; Stockpiler; Tie Back Shoring; Timber Faller and Bucker (hand labor); Toolroom Man (at job site); Tunnel Bullgang (above ground); Weight-Man- Crusher (aggregate when used)

GROUP 2: Applicator (including pot power tender for same), applying protective material by hand or nozzle on utility lines or storage tanks on project; Brush Cutters (power saw); Burners; Choker Splicer; Clary Power Spreader and similar types; Clean- up Nozzleman-Green Cutter (concrete, rock, etc.); Concrete Power Buggyman; Concrete Laborer; Crusher Feeder; Demolition and Wrecking Charred Materials; Guniting Nozzleman Tender; Guniting or Sand Blasting Pot Tender; Handlers or Mixers of all Materials of an irritating nature (including cement and lime); Tool Operators (includes but not limited to: Dry Pack Machine; Jackhammer; Chipping Guns; Paving Breakers); Pipe Doping and Wrapping; Post Hole Digger, air, gas or electric;

Vibrating Screed; Tampers; Sand Blasting (Wet); Stake-Setter; Tunnel-Muckers, Brakemen, Concrete Crew, Bullgang (underground)

GROUP 3: Asbestos Removal; Bit Grinder; Drill Doctor; Drill Operators, air tracks, cat drills, wagon drills, rubber-mounted drills, and other similar types including at crusher plants; Gunitite Nozzelman; High Scalers, Strippers and Drillers (covers work in swinging stages, chairs or belts, under extreme conditions unusual to normal drilling, blasting, barring-down, or sloping and stripping); Manhole Builder; Powdermen; Concrete Saw Operator; Powdermen; Power Saw Operators (Bucking and Falling); Pumpcrete Nozzlemen; Sand Blasting (Dry); Sewer Timberman; Track Liners, Anchor Machines, Ballast Regulators, Multiple Tampers, Power Jacks, Tugger Operator; Tunnel-Chuck Tenders, Nippers and Timbermen; Vibrator; Water Blaster

GROUP 4: Asphalt Raker; Concrete Saw Operator (walls); Concrete Nozzelman; Grade Checker; Pipelayer; Laser Beam (pipelaying)-applicable when employee assigned to move, set up, align; Laser Beam; Tunnel Miners; Motorman-Dinky Locomotive-Tunnel; Powderman-Tunnel; Shield Operator-Tunnel

GROUP 5: Traffic Flaggers

GROUP 6: Fence Builders

GROUP 7: Landscaping or Planting Laborers

LAB00335-019 06/01/2022

	Rates	Fringes
Hod Carrier.....	\$ 37.98	13.80

LAB00348-003 06/01/2022

CHELAN, DOUGLAS (W OF 12TH MERIDIAN), KITTITAS, AND YAKIMA COUNTIES

	Rates	Fringes
LABORER		
GROUP 1.....	\$ 25.37	13.80
GROUP 2.....	\$ 29.16	13.80
GROUP 3.....	\$ 31.94	13.80
GROUP 4.....	\$ 32.72	13.80
GROUP 5.....	\$ 32.09	13.19

BASE POINTS: BELLINGHAM, MT. VERNON, EVERETT, SEATTLE, KENT, TACOMA, OLYMPIA, CENTRALIA, ABERDEEN, SHELTON, PT. TOWNSEND, PT. ANGELES, AND BREMERTON

ZONE 1 - Projects within 25 radius miles of the respective city hall
 ZONE 2 - More than 25 but less than 45 radius miles from the respective city hall
 ZONE 3 - More than 45 radius miles from the respective city hall

ZONE DIFFERENTIAL (ADD TO ZONE 1 RATES):
 ZONE 2 - \$1.00
 ZONE 3 - \$1.30

BASE POINTS: CHELAN, SUNNYSIDE, WENATCHEE, AND YAKIMA

ZONE 1 - Projects within 25 radius miles of the respective

city hall
ZONE 2 - More than 25 radius miles from the respective city
hall

ZONE DIFFERENTIAL (ADD TO ZONE 1 RATES):
ZONE 2 - \$2.25

LABORERS CLASSIFICATIONS

GROUP 1: Landscaping and Planting; Watchman; Window Washer/Cleaner (detail clean-up, such as but not limited to cleaning floors, ceilings, walls, windows, etc., prior to final acceptance by the owner)

GROUP 2: Batch Weighman; Crusher Feeder; Fence Laborer; Flagman; Pilot Car

GROUP 3: General Laborer; Air, Gas, or Electric Vibrating Screed; Asbestos Abatement Laborer; Ballast Regulator Machine; Brush Cutter; Brush Hog Feeder; Burner; Carpenter Tender; Cement Finisher Tender; Change House or Dry Shack; Chipping Gun (under 30 lbs.); Choker Setter; Chuck Tender; Clean-up Laborer; Concrete Form Stripper; Curing Laborer; Demolition (wrecking and moving including charred material); Ditch Digger; Dump Person; Fine Graders; Firewatch; Form Setter; Gabian Basket Builders; Grout Machine Tender; Grinders; Guardrail Erector; Hazardous Waste Worker (Level C: uses a chemical "splash suit" and air purifying respirator); Maintenance Person; Material Yard Person; Pot Tender; Rip Rap Person; Riggers; Scale Person; Sloper Sprayer; Signal Person; Stock Piler; Stake Hopper; Toolroom Man (at job site); Topper-Tailer; Track Laborer; Truck Spotter; Vinyl Seamer

GROUP 4: Cement Dumper-Paving; Chipping Gun (over 30 lbs.); Clary Power Spreader; Concrete Dumper/Chute Operator; Concrete Saw Operator; Drill Operator (hydraulic, diamond, airtrac); Faller and Bucker Chain Saw; Grade Checker and Transit Person; Groutmen (pressure) including post tension beams; Hazardous Waste Worker (Level B: uses same respirator protection as Level A. A supplied air line is provided in conjunction with a chemical "splash suit"); High Scaler; Jackhammer; Laserbeam Operator; Manhole Builder-Mudman; Nozzleman (concrete pump, green cutter when using combination of high pressure air and water on concrete and rock, sandblast, gunite, shotcrete, water blaster, vacuum blaster); Pavement Breaker; Pipe Layer and Caulker; Pipe Pot Tender; Pipe Reliner (not insert type); Pipe Wrapper; Power Jacks; Railroad Spike Puller-Power; Raker-Asphalt; Rivet Buster; Rodder; Sloper (over 20 ft); Spreader (concrete); Tamper and Similar electric, air and glas operated tool; Timber Person-sewer (lagger shorer and cribber); Track Liner Power; Tugger Operator; Vibrator; Well Point Laborer

GROUP 5: Caisson Worker; Miner; Mortarman and Hodcarrier; Powderman; Re-Timberman; Hazardous Waste Worker (Level A: utilizes a fully encapsulated suit with a self-contained breathing apparatus or a supplied air line).

PAIN0005-002 07/01/2022

STATEWIDE EXCEPT CLARK, COWLITZ, KLUCKITAT, PACIFIC (SOUTH), SKAMANIA, AND WAHKIAKUM COUNTIES

Rates

Fringes

Painters:

STRIPERS.....\$ 33.37 18.53

PAIN0005-004 03/01/2009

CLALLAM, GRAYS HARBOR, ISLAND, JEFFERSON, KING, KITSAP, LEWIS,
MASON, PIERCE, SAN JUAN, SKAGIT, SNOHOMISH, THURSTON AND
WHATCOM COUNTIES

	Rates	Fringes
PAINTER.....	\$ 20.82	7.44

* PAIN0005-006 07/01/2018

ADAMS, ASOTIN; BENTON AND FRANKLIN (EXCEPT HANFORD SITE);
CHELAN, COLUMBIA, DOUGLAS, FERRY, GARFIELD, GRANT, KITTITAS,
LINCOLN, OKANOGAN, PEND OREILLE, SPOKANE, STEVENS, WALLA WALLA,
WHITMAN AND YAKIMA COUNTIES

	Rates	Fringes
PAINTER		
Application of Cold Tar		
Products, Epoxies, Polyure		
thanes, Acids, Radiation		
Resistant Material, Water		
and Sandblasting.....	\$ 30.19	11.71
Over 30'/Swing Stage Work..	\$ 22.20	7.98
Brush, Roller, Striping,		
Steam-cleaning and Spray....	\$ 22.94	11.61
Lead Abatement, Asbestos		
Abatement.....	\$ 21.50	7.98

*\$.70 shall be paid over and above the basic wage rates
listed for work on swing stages and high work of over 30
feet.

PAIN0055-003 04/01/2024

CLARK, COWLITZ, KLICKITAT, PACIFIC, SKAMANIA, AND WAHKIAKUM
COUNTIES

	Rates	Fringes
PAINTER		
Brush & Roller.....	\$ 37.69	14.92
Spray and Sandblasting.....	\$ 37.69	14.92

All high work over 60 ft. = base rate + \$.75

PAIN0055-006 04/01/2024

CLARK, COWLITZ, KLICKITAT, SKAMANIA and WAHKIAKUM COUNTIES

	Rates	Fringes
Painters:		
HIGHWAY & PARKING LOT		
STRIPER.....	\$ 37.69	14.92

PLAS0072-004 06/01/2023

ADAMS, ASOTIN, BENTON, CHELAN, COLUMBIA, DOUGLAS, FERRY,
FRANKLIN, GARFIELD, GRANT, KITTITAS, LINCOLN, OKANOGAN, PEND
OREILLE, SPOKANE, STEVENS, WALLA WALLA, WHITMAN, AND YAKIMA
COUNTIES

Rates Fringes

CEMENT MASON/CONCRETE FINISHER
ZONE 1.....\$ 38.05 16.89

Zone Differential (Add to Zone 1 rate): Zone 2 - \$3.00

BASE POINTS: Spokane, Pasco, Lewiston; Wenatchee
Zone 1: 0 - 45 radius miles from the main post office
Zone 2: Over 45 radius miles from the main post office

PLAS0528-001 06/01/2023

CLALLAM, COWLITZ, GRAYS HARBOR, ISLAND, JEFFERSON, KING,
KITSAP, LEWIS, MASON, PACIFIC, PIERCE, SAN JUAN, SKAGIT,
SNOHOMISH, THURSTON, WAHKIAKUM AND WHATCOM COUNTIES

Rates Fringes

CEMENT MASON
CEMENT MASON.....\$ 52.10 20.27
COMPOSITION, TROWEL
MACHINE, GRINDER, POWER
TOOLS, GUNNITE NOZZLE.....\$ 52.60 20.27
TROWELING MACHINE OPERATOR
ON COMPOSITION.....\$ 52.60 20.27

PLAS0555-002 06/01/2023

CLARK, KLICKITAT AND SKAMANIA COUNTIES

ZONE 1:

Rates Fringes

CEMENT MASON
CEMENT MASONS DOING BOTH
COMPOSITION/POWER
MACHINERY AND
SUSPENDE/HANGING SCAFFOLD..\$ 45.06 19.95
CEMENT MASONS ON
SUSPENDE, SWINGING AND/OR
HANGING SCAFFOLD.....\$ 44.19 19.95
CEMENT MASONS.....\$ 43.33 19.95
COMPOSITION WORKERS AND
POWER MACHINERY OPERATORS...\$ 44.19 19.95

Zone Differential (Add To Zone 1 Rates):
Zone 2 - \$0.65
Zone 3 - 1.15
Zone 4 - 1.70
Zone 5 - 3.00

BASE POINTS: BEND, CORVALLIS, EUGENE, MEDFORD, PORTLAND,
SALEM, THE DALLES, VANCOUVER

ZONE 1: Projects within 30 miles of the respective city hall
ZONE 2: More than 30 miles but less than 40 miles from the
respective city hall.
ZONE 3: More than 40 miles but less than 50 miles from the
respective city hall.
ZONE 4: More than 50 miles but less than 80 miles from the
respective city hall.
ZONE 5: More than 80 miles from the respective city hall

CLARK, COWLITZ, KLUCKITAT, PACIFIC (South of a straight line made by extending the north boundary line of Wahkiakum County west to the Pacific Ocean), SKAMANIA, AND WAHAKIAKUM COUNTIES

Rates Fringes

Truck drivers:

ZONE 1		
GROUP 1.....	\$ 29.33	16.40
GROUP 2.....	\$ 29.46	16.40
GROUP 3.....	\$ 29.60	16.40
GROUP 4.....	\$ 29.89	16.40
GROUP 5.....	\$ 30.03	16.40
GROUP 6.....	\$ 30.31	16.40
GROUP 7.....	\$ 30.53	16.40

Zone Differential (Add to Zone 1 Rates):

- Zone 2 - \$0.65
- Zone 3 - 1.15
- Zone 4 - 1.70
- Zone 5 - 2.75

BASE POINTS: ASTORIA, THE DALLES, LONGVIEW AND VANCOUVER

ZONE 1: Projects within 30 miles of the respective city hall.

ZONE 2: More than 30 miles but less than 40 miles from the respective city hall.

ZONE 3: More than 40 miles but less than 50 miles from the respective city hall.

ZONE 4: More than 50 miles but less than 80 miles from the respective city hall.

ZONE 5: More than 80 miles from the respective city hall.

TRUCK DRIVERS CLASSIFICATIONS

GROUP 1: A Frame or Hydra lift truck w/load bearing surface; Articulated Dump Truck; Battery Rebuilders; Bus or Manhaul Driver; Concrete Buggies (power operated); Concrete Pump Truck; Dump Trucks, side, end and bottom dumps, including Semi Trucks and Trains or combinations there of: up to and including 10 cu. yds.; Lift Jitneys, Fork Lifts (all sizes in loading, unloading and transporting material on job site); Loader and/or Leverman on Concrete Dry Batch Plant (manually operated); Pilot Car; Pickup Truck; Solo Flat Bed and misc. Body Trucks, 0-10 tons; Truck Tender; Truck Mechanic Tender; Water Wagons (rated capacity) up to 3,000 gallons; Transit Mix and Wet or Dry Mix - 5 cu. yds. and under; Lubrication Man, Fuel Truck Driver, Tireman, Wash Rack, Steam Cleaner or combinations; Team Driver; Slurry Truck Driver or Leverman; Tireman

GROUP 2: Boom Truck/Hydra-lift or Retracting Crane; Challenger; Dumpsters or similar equipment all sizes; Dump Trucks/Articulated Dumps 6 cu to 10 cu.; Flaherty Spreader Driver or Leverman; Lowbed Equipment, Flat Bed Semi-trailer or doubles transporting equipment or wet or dry materials; Lumber Carrier, Driver-Straddle Carrier (used in loading, unloading and transporting of materials on job site); Oil Distributor Driver or Leverman; Transit mix and wet or dry mix trucks: over 5 cu. yds. and including 7 cu. yds.; Vacuum Trucks; Water truck/Wagons (rated capacity) over 3,000 to 5,000 gallons

GROUP 3: Ammonia Nitrate Distributor Driver; Dump trucks, side, end and bottom dumps, including Semi Trucks and Trains or combinations thereof: over 10 cu. yds. and including 30 cu. yds. includes Articulated Dump Trucks; Self-Propelled Street Sweeper; Transit mix and wet or dry mix truck: over 7 cu yds. and including 11 cu yds.; Truck Mechanic-Welder-Body Repairman; Utility and Clean-up Truck; Water Wagons (rated capacity) over 5,000 to 10,000 gallons

GROUP 4: Asphalt Burner; Dump Trucks, side, end and bottom cumps, including Semi-Trucks and Trains or combinations thereof: over 30 cu. yds. and including 50 cu. yds. includes Articulated Dump Trucks; Fire Guard; Transit Mix and Wet or Dry Mix Trucks, over 11 cu. yds. and including 15 cu. yds.; Water Wagon (rated capacity) over 10,000 gallons to 15,000 gallons

GROUP 5: Composite Crewman; Dump Trucks, side, end and bottom dumps, including Semi Trucks and Trains or combinations thereof: over 50 cu. yds. and including 60 cu. yds. includes Articulated Dump Trucks

GROUP 6: Bulk Cement Spreader w/o Auger; Dry Pre-Batch concrete Mix Trucks; Dump trucks, side, end and bottom dumps, including Semi Trucks and Trains of combinations thereof: over 60 cu. yds. and including 80 cu. yds., and includes Articulated Dump Trucks; Skid Truck

GROUP 7: Dump Trucks, side, end and bottom dumps, including Semi Trucks and Trains or combinations thereof: over 80 cu. yds. and including 100 cu. yds., includes Articulated Dump Trucks; Industrial Lift Truck (mechanical tailgate)

 * TEAM0174-001 06/01/2020

CLALLAM, GRAYS HARBOR, ISLAND, JEFFERSON, KING, KITSAP, LEWIS, MASON, PACIFIC (North of a straight line made by extending the north boundary line of Wahkiakum County west to the Pacific Ocean), PIERCE, SAN JUAN, SKAGIT, SNOHOMISH, THURSTON AND WHATCOM COUNTIES

Rates Fringes

Truck drivers:

ZONE A:

GROUP 1:.....	\$ 42.88	20.92
GROUP 2:.....	\$ 42.04	20.92
GROUP 3:.....	\$ 39.23	20.92
GROUP 4:.....	\$ 34.26	20.92
GROUP 5:.....	\$ 42.43	20.92

ZONE B (25-45 miles from center of listed cities*): Add \$.70 per hour to Zone A rates.

ZONE C (over 45 miles from centr of listed cities*): Add \$1.00 per hour to Zone A rates.

*Zone pay will be calculated from the city center of the following listed cities:

BELLINGHAM	CENTRALIA	RAYMOND	OLYMPIA
EVERETT	SHELTON	ANACORTES	BELLEVUE
SEATTLE	PORT ANGELES	MT. VERNON	KENT
TACOMA	PORT TOWNSEND	ABERDEEN	BREMERTON

TRUCK DRIVERS CLASSIFICATIONS

GROUP 1 - ""A-frame or Hydralift"" trucks and Boom trucks or

similar equipment when "A" frame or "Hydralift" and Boom truck or similar equipment is used; Buggymobile; Bulk Cement Tanker; Dumpsters and similar equipment, Tournorockers, Tournowagon, Turnotrailer, Cat DW series, Terra Cobra, Le Tourneau, Westinghouse, Athye Wagon, Euclid Two and Four-Wheeled power tractor with trailer and similar top-loaded equipment transporting material: Dump Trucks, side, end and bottom dump, including semi-trucks and trains or combinations thereof with 16 yards to 30 yards capacity: Over 30 yards \$.15 per hour additional for each 10 yard increment; Explosive Truck (field mix) and similar equipment; Hyster Operators (handling bulk loose aggregates); Lowbed and Heavy Duty Trailer; Road Oil Distributor Driver; Spreader, Flaherty Transit mix used exclusively in heavy construction; Water Wagon and Tank Truck-3,000 gallons and over capacity

GROUP 2 - Bulllifts, or similar equipment used in loading or unloading trucks, transporting materials on job site; Dumpsters, and similar equipment, Tournorockers, Tournowagon, Turnotrailer, Cat. D.W. Series, Terra Cobra, Le Tourneau, Westinghouse, Athye wagon, Euclid two and four-wheeled power tractor with trailer and similar top-loaded equipment transporting material: Dump trucks, side, end and bottom dump, including semi-trucks and trains or combinations thereof with less than 16 yards capacity; Flatbed (Dual Rear Axle); Grease Truck, Fuel Truck, Greaser, Battery Service Man and/or Tire Service Man; Leverman and loader at bunkers and batch plants; Oil tank transport; Scissor truck; Slurry Truck; Sno-Go and similar equipment; Swampers; Straddler Carrier (Ross, Hyster) and similar equipment; Team Driver; Tractor (small, rubber-tired)(when used within Teamster jurisdiction); Vacuum truck; Water Wagon and Tank trucks-less than 3,000 gallons capacity; Winch Truck; Wrecker, Tow truck and similar equipment

GROUP 3 - Flatbed (single rear axle); Pickup Sweeper; Pickup Truck. (Adjust Group 3 upward by \$2.00 per hour for onsite work only)

GROUP 4 - Escort or Pilot Car

GROUP 5 - Mechanic

HAZMAT PROJECTS

Anyone working on a HAZMAT job, where HAZMAT certification is required, shall be compensated as a premium, in addition to the classification working in as follows:

LEVEL C: +\$.25 per hour - This level uses an air purifying respirator or additional protective clothing.

LEVEL B: +\$.50 per hour - Uses same respirator protection as Level A. Supplied air line is provided in conjunction with a chemical "splash suit."

LEVEL A: +\$.75 per hour - This level utilizes a fully-encapsulated suit with a self-contained breathing apparatus or a supplied air line.

TEAM0690-004 01/01/2019

ADAMS, ASOTIN, BENTON, CHELAN, COLUMBIA, DOUGLAS, FERRY, FRANKLIN, GARFIELD, GRANT KITTITAS, LINCOLN, OKANOGAN, PEND OREILLE, SPOKANE, STEVENS, WALLA WALLA, WHITMAN AND YAKIMA COUNTIES

Rates

Fringes

Truck drivers: (AREA 1:
SPOKANE ZONE CENTER: Adams,
Chelan, Douglas, Ferry,
Grant, Kittitas, Lincoln,
Okanogan, Pen Oreille,
Spokane, Stevens, and Whitman
Counties

AREA 1: LEWISTON ZONE CENTER:
Asotin, Columbia, and
Garfield Counties

AREA 2: PASCO ZONE CENTER:
Benton, Franklin, Walla Walla
and Yakima Counties)

AREA 1:		
GROUP 1.....	\$ 23.91	17.40
GROUP 2.....	\$ 26.18	17.40
GROUP 3.....	\$ 26.68	17.40
GROUP 4.....	\$ 27.01	17.40
GROUP 5.....	\$ 27.12	17.40
GROUP 6.....	\$ 27.29	17.40
GROUP 7.....	\$ 27.82	17.40
GROUP 8.....	\$ 28.18	17.40
AREA 2:		
GROUP 1.....	\$ 26.05	17.40
GROUP 2.....	\$ 28.69	17.40
GROUP 3.....	\$ 28.80	17.40
GROUP 4.....	\$ 29.13	17.40
GROUP 5.....	\$ 29.24	17.40
GROUP 6.....	\$ 29.24	17.40
GROUP 7.....	\$ 29.78	17.40
GROUP 8.....	\$ 30.10	17.40

Zone Differential (Add to Zone 1 rate: Zone 1 + \$2.00)

BASE POINTS: Spokane, Pasco, Lewiston
Zone 1: 0-45 radius miles from the main post office.
Zone 2: Outside 45 radius miles from the main post office

TRUCK DRIVERS CLASSIFICATIONS

GROUP 1: Escort Driver or Pilot Car; Employee Haul; Power
Boat Hauling Employees or Material

GROUP 2: Fish Truck; Flat Bed Truck; Fork Lift (3000 lbs. and
under); Leverperson (loading trucks at bunkers); Trailer
Mounted Hydro Seeder and Mulcher; Seeder & Mulcher;
Stationary Fuel Operator; Tractor (small, rubber-tired,
pulling trailer or similar equipment)

GROUP 3: Auto Crane (2000 lbs. capacity); Buggy Mobile &
Similar; Bulk Cement Tanks & Spreader; Dumptor (6 yds. &
under); Flat Bed Truck with Hydraulic System; Fork Lift
(3001-16,000 lbs.); Fuel Truck Driver, Steamcleaner &
Washer; Power Operated Sweeper; Rubber-tired Tunnel Jumbo;
Scissors Truck; Slurry Truck Driver; Straddle Carrier
(Ross, Hyster, & similar); Tireperson; Transit Mixers &
Truck Hauling Concrete (3 yd. to & including 6 yds.);
Trucks, side, end, bottom & articulated end dump (3 yards
to and including 6 yds.); Warehouseperson (to include
shipping & receiving); Wrecker & Tow Truck

GROUP 4: A-Frame; Burner, Cutter, & Welder; Service Greaser;
Trucks, side, end, bottom & articulated end dump (over 6
yards to and including 12 yds.); Truck Mounted Hydro
Seeder; Warehouseperson; Water Tank truck (0-8,000 gallons)

GROUP 5: Dumptor (over 6 yds.); Lowboy (50 tons & under);

Self-loading Roll Off; Semi-Truck & Trailer; Tractor with Steer Trailer; Transit Mixers and Trucks Hauling Concrete (over 6 yds. to and including 10 yds.); Trucks, side, end, bottom and end dump (over 12 yds. to & including 20 yds.); Truck-Mounted Crane (with load bearing surface either mounted or pulled, up to 14 ton); Vacuum Truck (super sucker, guzzler, etc.)

GROUP 6: Flaherty Spreader Box Driver; Flowboys; Fork Lift (over 16,000 lbs.); Dumps (Semi-end); Mechanic (Field); Semi-end Dumps; Transfer Truck & Trailer; Transit Mixers & Trucks Hauling Concrete (over 10 yds. to & including 20 yds.); Trucks, side, end, bottom and articulated end dump (over 20 yds. to & including 40 yds.); Truck and Pup; Tournarocker, DWs & similar with 2 or more 4 wheel-power tractor with trailer, gallonage or yardage scale, whichever is greater Water Tank Truck (8,001- 14,000 gallons); Lowboy(over 50 tons)

GROUP 7: Oil Distributor Driver; Stringer Truck (cable operated trailer); Transit Mixers & Trucks Hauling Concrete (over 20 yds.); Truck, side, end, bottom end dump (over 40 yds. to & including 100 yds.); Truck Mounted Crane (with load bearing surface either mounted or pulled (16 through 25 tons);

GROUP 8: Prime Movers and Stinger Truck; Trucks, side, end, bottom and articulated end dump (over 100 yds.); Helicopter Pilot Hauling Employees or Materials

Footnote A - Anyone working on a HAZMAT job, where HAZMAT certification is required, shall be compensated as a premium, in addition to the classification working in as follows:

LEVEL C-D: - \$.50 PER HOUR (This is the lowest level of protection. This level may use an air purifying respirator or additional protective clothing.

LEVEL A-B: - \$1.00 PER HOUR (Uses supplied air in conjunction with a chemical splash suit or fully encapsulated suit with a self-contained breathing apparatus.

Employees shall be paid Hazmat pay in increments of four(4) and eight(8) hours.

NOTE:
Trucks Pulling Equipment Trailers: shall receive \$.15/hour over applicable truck rate

WELDERS - Receive rate prescribed for craft performing operation to which welding is incidental.

=====

Note: Executive Order (EO) 13706, Establishing Paid Sick Leave for Federal Contractors applies to all contracts subject to the Davis-Bacon Act for which the contract is awarded (and any solicitation was issued) on or after January 1, 2017. If this contract is covered by the EO, the contractor must provide employees with 1 hour of paid sick leave for every 30 hours they work, up to 56 hours of paid sick leave each year. Employees must be permitted to use paid sick leave for their own illness, injury or other health-related needs, including preventive care; to assist a family member (or person who is like family to the employee) who is ill, injured, or has other health-related needs, including preventive care; or for reasons resulting from, or to assist a family member (or person who is

like family to an employee) who is a victim of, domestic violence, sexual assault, or stalking. Additional information on contractor requirements and worker protections under the EO is available at <https://www.dol.gov/agencies/whd/government-contracts>.

Unlisted classifications needed for work not included within the scope of the classifications listed may be added after award only as provided in the labor standards contract clauses (29CFR 5.5 (a) (1) (iii)).

The body of each wage determination lists the classification and wage rates that have been found to be prevailing for the cited type(s) of construction in the area covered by the wage determination. The classifications are listed in alphabetical order of ""identifiers"" that indicate whether the particular rate is a union rate (current union negotiated rate for local), a survey rate (weighted average rate) or a union average rate (weighted union average rate).

Union Rate Identifiers

A four letter classification abbreviation identifier enclosed in dotted lines beginning with characters other than ""SU"" or ""UAVG"" denotes that the union classification and rate were prevailing for that classification in the survey. Example: PLUM0198-005 07/01/2014. PLUM is an abbreviation identifier of the union which prevailed in the survey for this classification, which in this example would be Plumbers. 0198 indicates the local union number or district council number where applicable, i.e., Plumbers Local 0198. The next number, 005 in the example, is an internal number used in processing the wage determination. 07/01/2014 is the effective date of the most current negotiated rate, which in this example is July 1, 2014.

Union prevailing wage rates are updated to reflect all rate changes in the collective bargaining agreement (CBA) governing this classification and rate.

Survey Rate Identifiers

Classifications listed under the ""SU"" identifier indicate that no one rate prevailed for this classification in the survey and the published rate is derived by computing a weighted average rate based on all the rates reported in the survey for that classification. As this weighted average rate includes all rates reported in the survey, it may include both union and non-union rates. Example: SULA2012-007 5/13/2014. SU indicates the rates are survey rates based on a weighted average calculation of rates and are not majority rates. LA indicates the State of Louisiana. 2012 is the year of survey on which these classifications and rates are based. The next number, 007 in the example, is an internal number used in producing the wage determination. 5/13/2014 indicates the survey completion date for the classifications and rates under that identifier.

Survey wage rates are not updated and remain in effect until a new survey is conducted.

Union Average Rate Identifiers

Classification(s) listed under the UAVG identifier indicate that no single majority rate prevailed for those classifications; however, 100% of the data reported for the classifications was union data. EXAMPLE: UAVG-OH-0010

08/29/2014. UAVG indicates that the rate is a weighted union average rate. OH indicates the state. The next number, 0010 in the example, is an internal number used in producing the wage determination. 08/29/2014 indicates the survey completion date for the classifications and rates under that identifier.

A UAVG rate will be updated once a year, usually in January of each year, to reflect a weighted average of the current negotiated/CBA rate of the union locals from which the rate is based.

State Adopted Rate Identifiers

Classifications listed under the "SA" identifier indicate that the prevailing wage rate set by a state (or local) government was adopted under 29 C.F.R. 1.3(g)-(h). Example: SAME2023-007 01/03/2024. SA reflects that the rates are state adopted. ME refers to the State of Maine. 2023 is the year during which the state completed the survey on which the listed classifications and rates are based. The next number, 007 in the example, is an internal number used in producing the wage determination. 01/03/2024 reflects the date on which the classifications and rates under the "SA" identifier took effect under state law in the state from which the rates were adopted.

WAGE DETERMINATION APPEALS PROCESS

1.) Has there been an initial decision in the matter? This can be:

- * an existing published wage determination
- * a survey underlying a wage determination
- * a Wage and Hour Division letter setting forth a position on a wage determination matter
- * a conformance (additional classification and rate) ruling

On survey related matters, initial contact, including requests for summaries of surveys, should be with the Wage and Hour National Office because National Office has responsibility for the Davis-Bacon survey program. If the response from this initial contact is not satisfactory, then the process described in 2.) and 3.) should be followed.

With regard to any other matter not yet ripe for the formal process described here, initial contact should be with the Branch of Construction Wage Determinations. Write to:

Branch of Construction Wage Determinations
Wage and Hour Division
U.S. Department of Labor
200 Constitution Avenue, N.W.
Washington, DC 20210

2.) If the answer to the question in 1.) is yes, then an interested party (those affected by the action) can request review and reconsideration from the Wage and Hour Administrator (See 29 CFR Part 1.8 and 29 CFR Part 7). Write to:

Wage and Hour Administrator
U.S. Department of Labor
200 Constitution Avenue, N.W.
Washington, DC 20210

The request should be accompanied by a full statement of the interested party's position and by any information (wage payment data, project description, area practice material, etc.) that the requestor considers relevant to the issue.

3.) If the decision of the Administrator is not favorable, an interested party may appeal directly to the Administrative Review Board (formerly the Wage Appeals Board). Write to:

Administrative Review Board
U.S. Department of Labor
200 Constitution Avenue, N.W.
Washington, DC 20210

4.) All decisions by the Administrative Review Board are final.

=====

END OF GENERAL DECISION"

Appendix C

Standard Plans

302.0151 – South Tacoma Way – 96th to Steilacoom Overlay

STANDARD PLANS LIST

WSDOT Standard Plans

F40.12-03	Parallel Curb Ramp
F45.10-04	Detectible Warning Surface
I40.20-00	Inlet Protection

Pierce County Standard Drawings

PC.H2.1 thru PC.H2.9	Pavement Markings
PC.H2.10	Temporary Pavement Markings Short Duration

City of Lakewood Standard Plans

FR-03	Cement Concrete Sidewalk
FR-04	Curbs
PS-04	Bicycle Lane Symbol Layout

Pierce County Sewer Utility Standard Details

1002	Concrete Manhole Collar
1003	Public Manhole Frame and Locking Lid

DRAWN BY: FERN LIDDELL

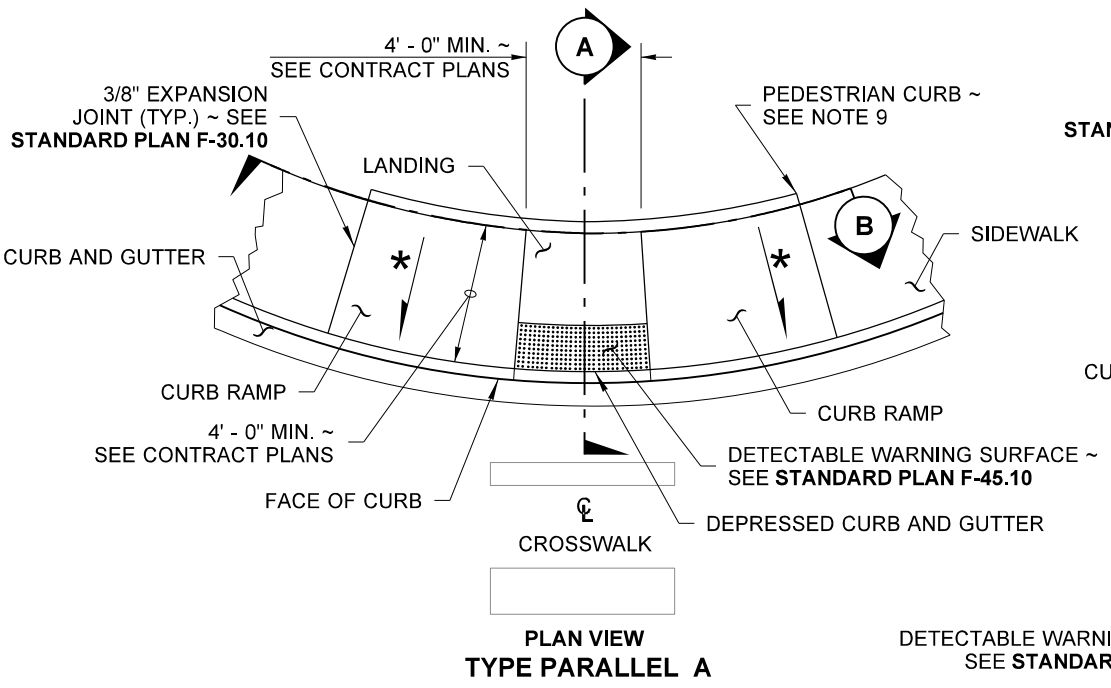

**PLAN VIEW
TYPE PARALLEL A**

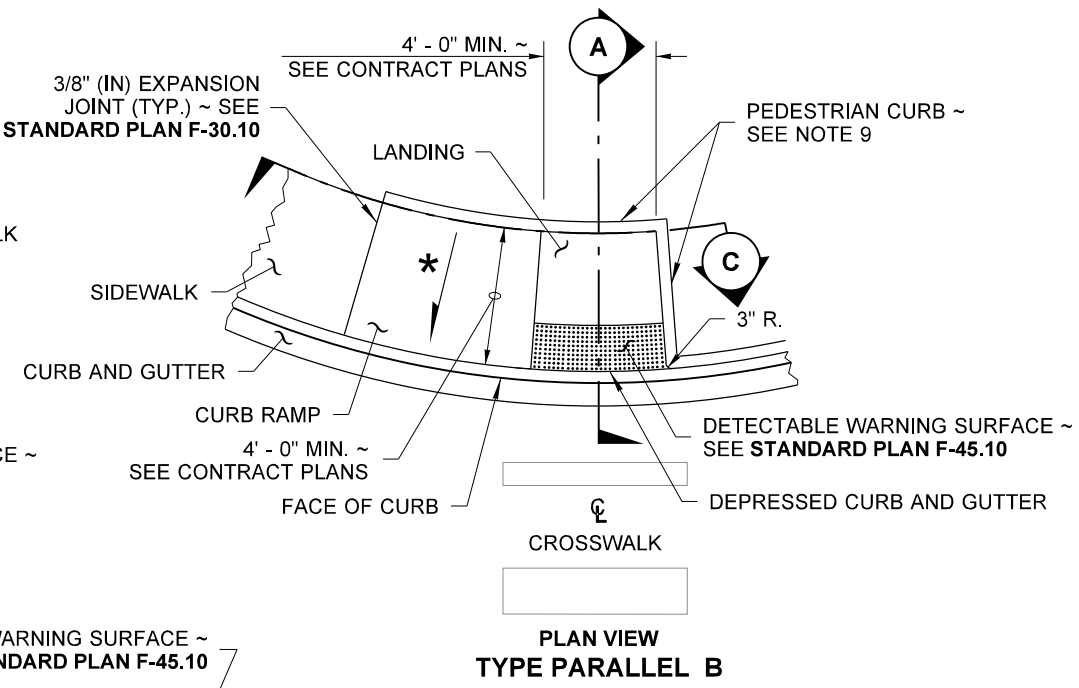

**PLAN VIEW
TYPE PARALLEL B**

1 CONTRACTION JOINT (TYP.) ~ SEE **STANDARD PLAN F-30.1** FOR CURB RAMP LENGTHS GREATER THAN 8' - 0" PROVIDE CONTRACTION JOINT EQUALLY SPACED 4' - 0" MIN. OC.

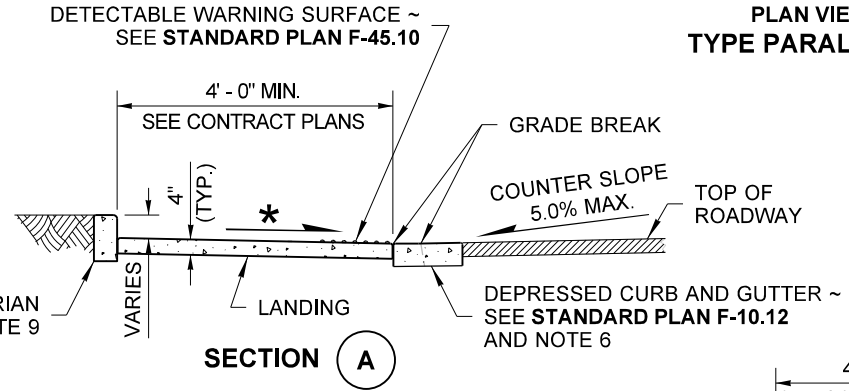

SECTION A

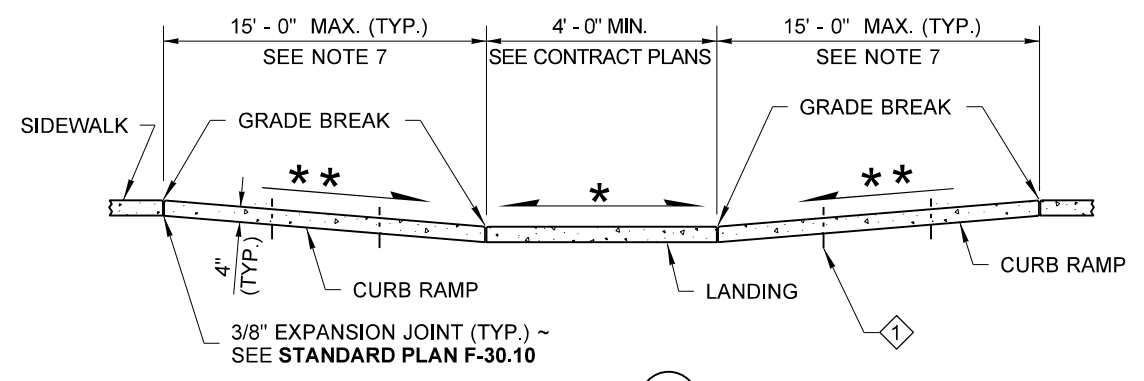

SECTION B
(ALONG INSIDE RADIUS AT BACK OF WALKWAY)

"CEMENT CONCRETE CURB RAMP TYPE PARALLEL A" PAY LIMIT ~ SEE NOTE 6

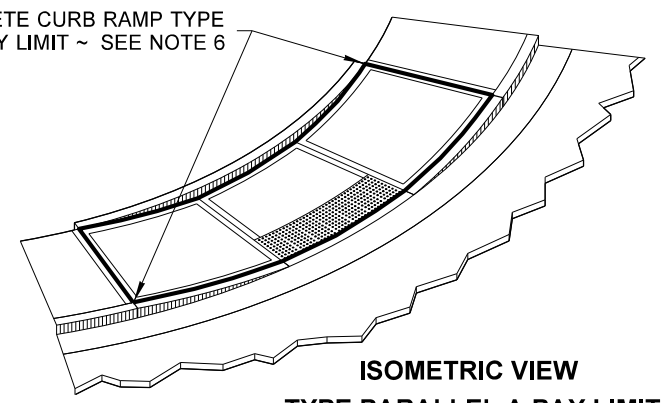

**ISOMETRIC VIEW
TYPE PARALLEL A PAY LIMIT**

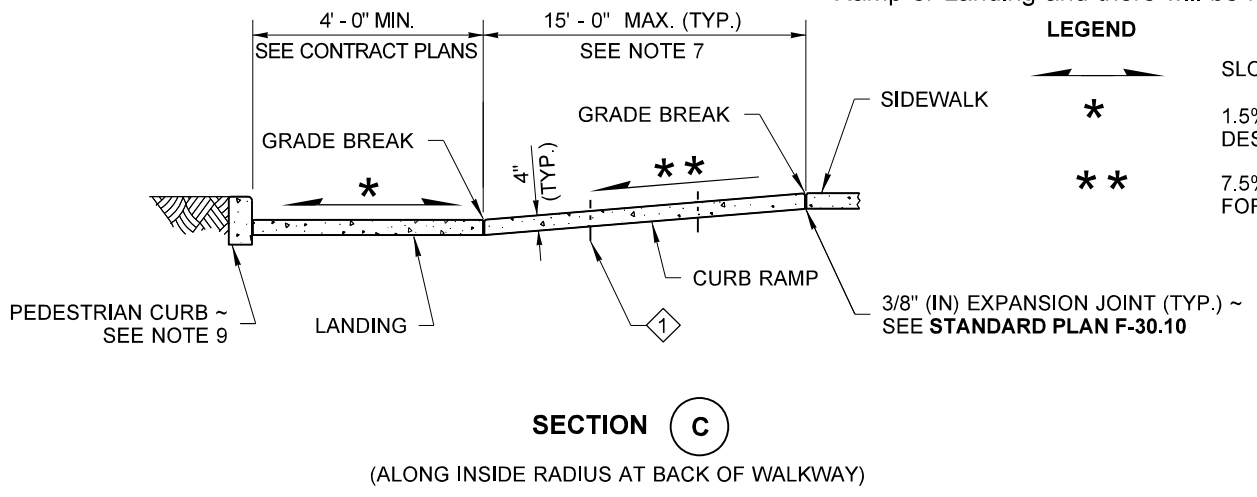

SECTION C
(ALONG INSIDE RADIUS AT BACK OF WALKWAY)

"CEMENT CONCRETE CURB RAMP TYPE PARALLEL B" PAY LIMIT ~ SEE NOTE 6

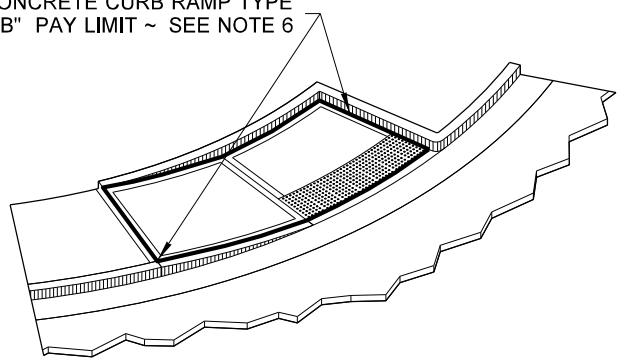

**ISOMETRIC VIEW
TYPE PARALLEL B PAY LIMIT**

NOTES

- At marked crosswalks, the connection between the landing and the roadway must be contained within the width of the crosswalk markings.
- Where "GRADE BREAK" is called out, the entire length of the grade break between the two adjacent surface planes shall be flush.
- Do not place Gratings, Junction Boxes, Access Covers, or other appurtenances on any part of the Curb Ramp or Landing, or in the Depressed Curb and Gutter where the Landing connects to the roadway.
- See Contract Plans for the curb design specified. See **Standard Plan F-10.12** for Curb, Curb and Gutter, Depressed Curb and Gutter, and Pedestrian Curb details.
- See **Standard Plan F-30.10** for Cement Concrete Sidewalk Details. See Contract Plans for width and placement of sidewalk.
- The Bid Item "Cement Concrete Curb Ramp Type ___" does not include the adjacent Curb, Curb and Gutter, Depressed Curb and Gutter, Pedestrian Curb, or Sidewalks.
- The Curb Ramp length is not required to exceed 15 feet (unless otherwise shown in the Contract Plans). When applying the 15-foot max. length, the running slope of the curb ramp is allowed to exceed 8.3%. Use a single constant slope from bottom of ramp to top of ramp to match into the sidewalk over a horizontal distance of 15 feet. Do not include abutting landing(s) in the 15-foot max. measurement. When a ramp is constructed on a radius, the 15-foot max. length is measured on the inside radius along the back of the walkway.
- Curb Ramps and Landings shall receive a broom finish. See **Standard Specifications 8-14**.
- Pedestrian Curb may be omitted if the ground surface at the back of the Curb Ramp and/or Landing will be at the same elevation as the Curb Ramp or Landing and there will be no material to retain.

LEGEND

- SLOPE IN EITHER DIRECTION
- 1.5% OR FLATTER RECOMMENDED FOR DESIGN/FORMWORK (2% MAX.)
- 7.5% OR FLATTER RECOMMENDED FOR DESIGN/FORMWORK (8.3% MAX.) ~ SEE NOTE 7



**PARALLEL CURB RAMP
STANDARD PLAN F-40.12-03**

SHEET 1 OF 1 SHEET

APPROVED FOR PUBLICATION



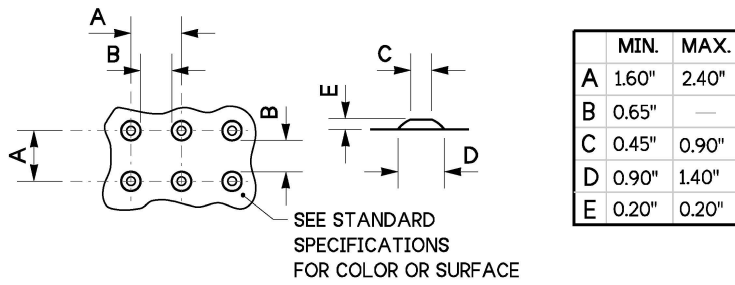

TRUNCATED DOME DETAILS
SEE NOTE 3

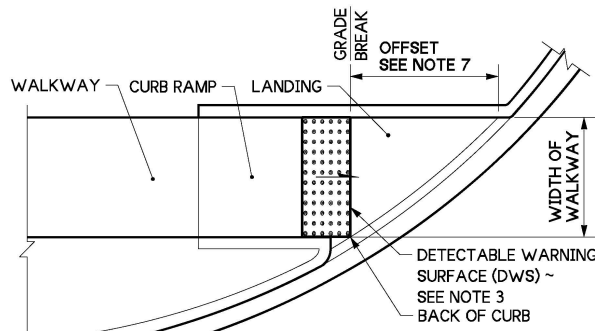

SINGLE DIRECTION CURB RAMP
(GRADE BREAK BETWEEN CURB AND LANDING < 5 FEET FROM BACK OF CURB)
(SEE NOTE 5)

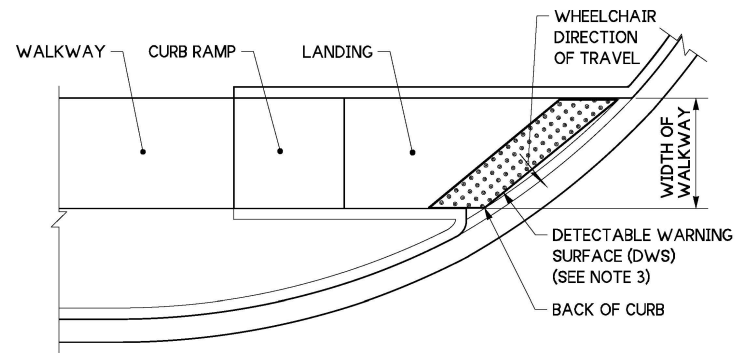

SINGLE DIRECTION CURB RAMP
(GRADE BREAK BETWEEN CURB AND LANDING > 5 FEET FROM BACK OF CURB)
(SEE NOTE 5)

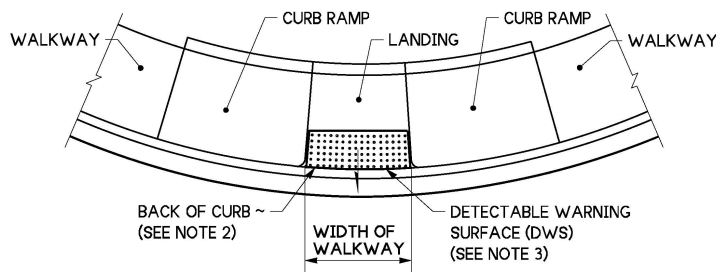

PARALLEL CURB RAMP
(SEE NOTE 6)

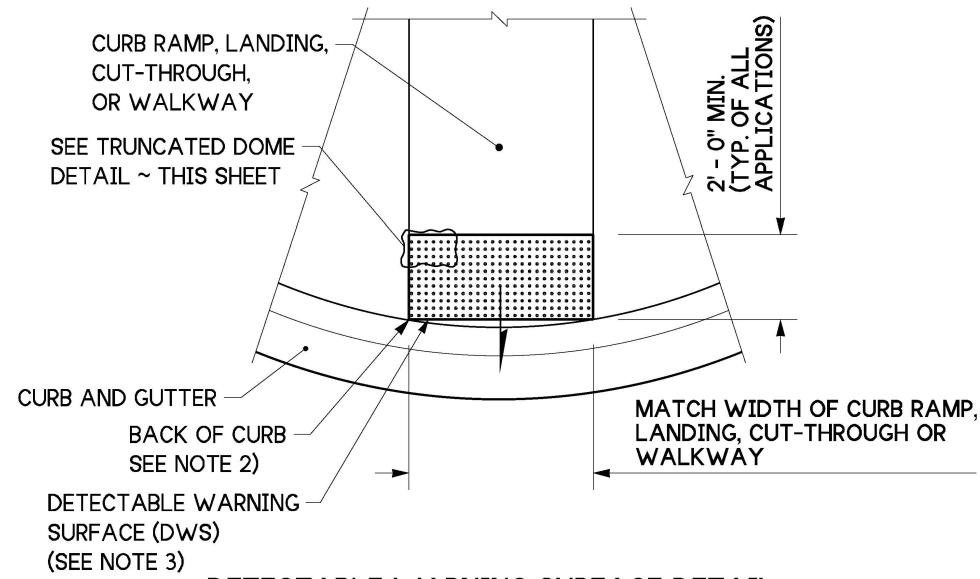

DETECTABLE WARNING SURFACE DETAIL

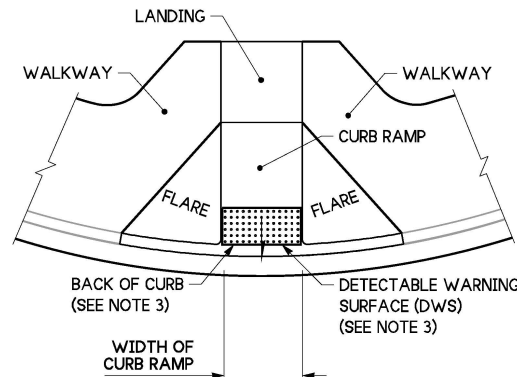

PERPENDICULAR CURB RAMP
(SEE NOTE 6)

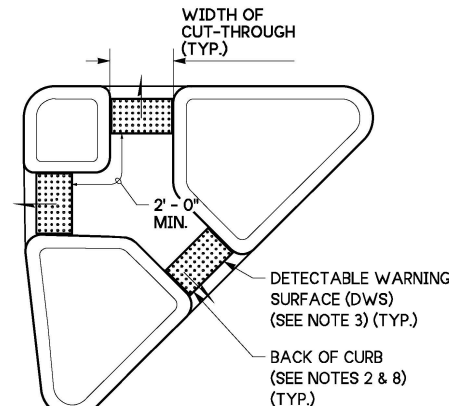

ISLAND CUT-THROUGH

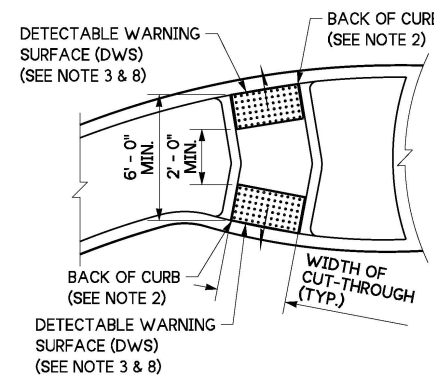

ROUNDBOUT SPLITTER ISLAND

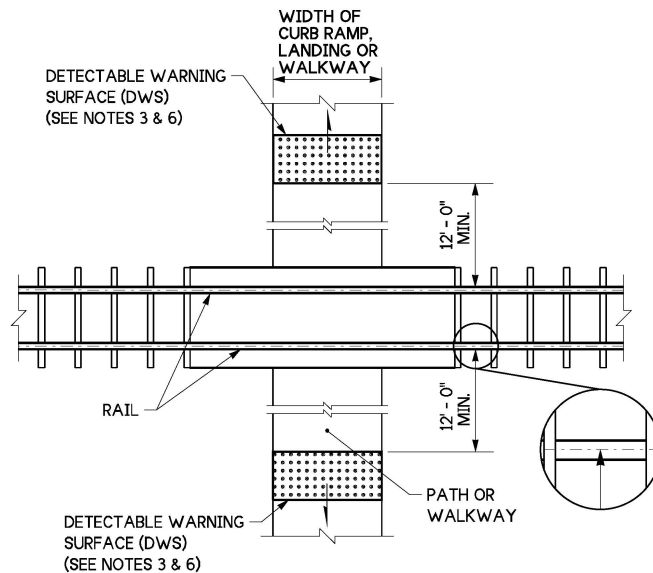

PEDESTRIAN RAILROAD CROSSING

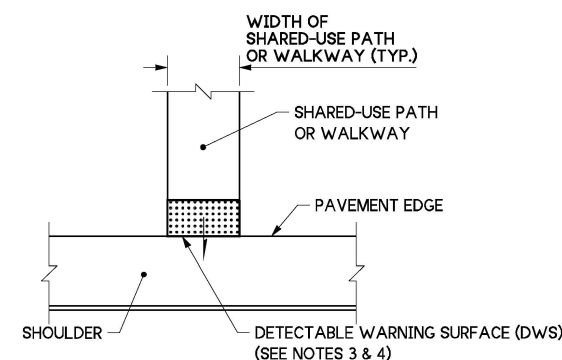

SHARED-USE PATH CONNECTION

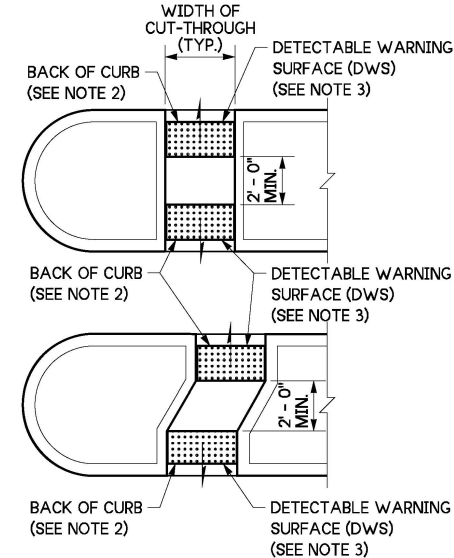

MEDIAN CUT-THROUGH

LEGEND
DIRECTION OF TRAVEL

NOTES

1. Permanent Detectable Warning Surfaces (DWS) shall extend the full width of the curb ramp, landing, or other roadway entrance as applicable. Exception: If the manufacturer of the DWS requires a concrete border around the DWS, a variance of up to 2" (in) on each side of the DWS is permitted.
2. Permanent Detectable Warning Surfaces (DWS) shall be placed on a minimum 4" (in) thick concrete pad. The DWS panel shall be placed adjacent to the back of the curb and with no more than a 2" (in) gap between the DWS and the back of the curb measured at the center of the DWS panel. Exception: if the Manufacturer of the selected DWS requires a concrete border around the DWS, a variance of up to 2" (in) from the back of the curb is permitted (measured at the leading corners of the DWS panel).
3. The rows of truncated domes shall be aligned to be parallel to the direction of travel, and perpendicular to the grade break at the back of curb.
4. If curb and gutter are not present, such as a shared-use path connection, the Detectable Warning Surface shall be placed at the pavement edge.
5. See Standard Plans for sidewalk and curb ramp details.
6. If a curb ramp is required, the location of the Detectable Warning Surface must be at the bottom of the ramp and within the required distance from the rail crossing.
7. When the grade break between the curb ramp and the landing is less than or equal to 5 feet from the back of curb at all points, place the Detectable Warning Surface on the bottom of the curb ramp directly above the grade break.
8. Glued or stick down Detectable Warning Surfaces are allowed only for temporary work zone applications.



Oct 13, 2023

DETECTABLE WARNING SURFACE
STANDARD PLAN F-45.10-04

SHEET 1 OF 1 SHEET

APPROVED FOR PUBLICATION

Mark A. Davis

Oct 16, 2023

STATE DESIGN ENGINEER



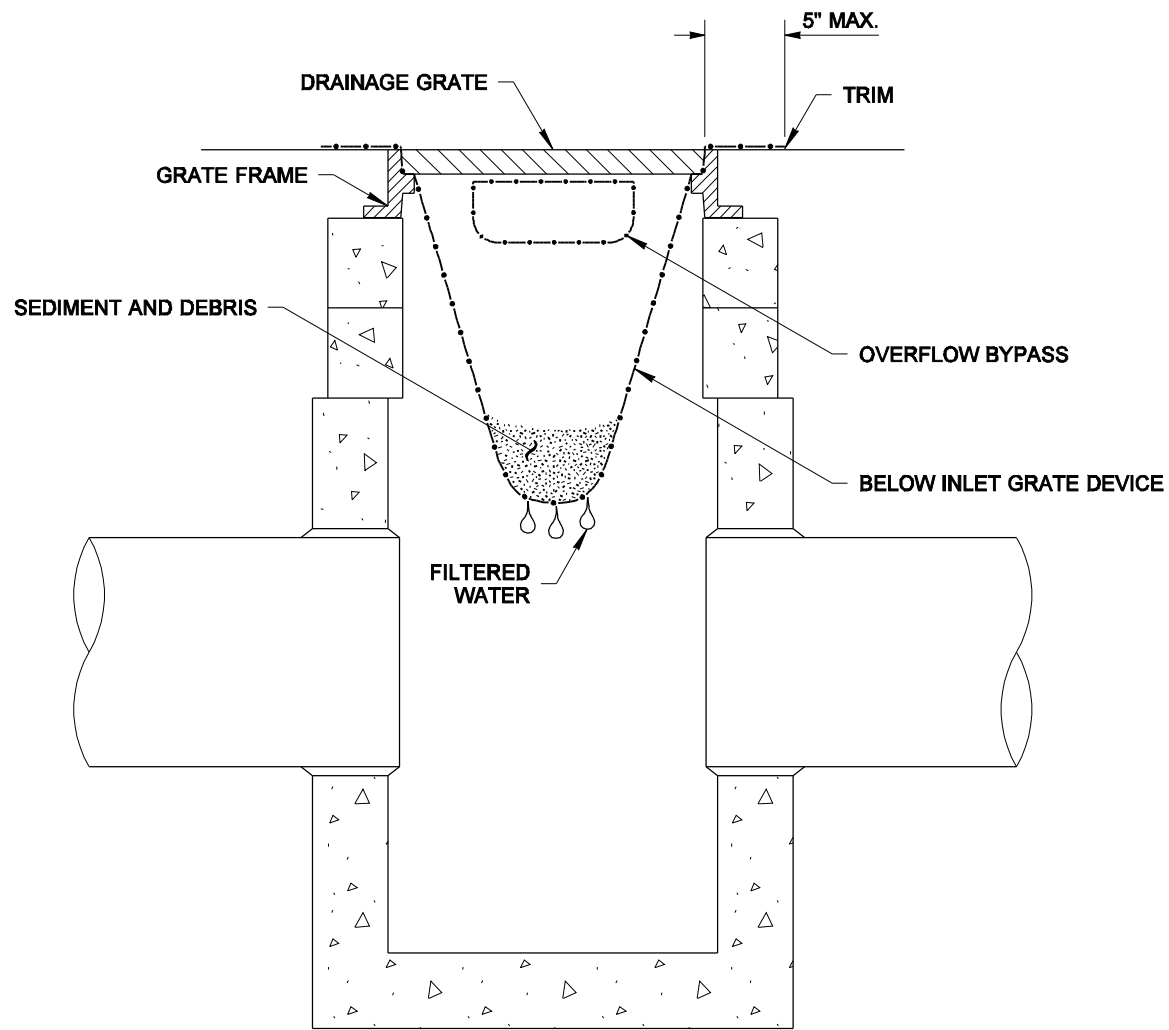

SECTION VIEW
NOT TO SCALE

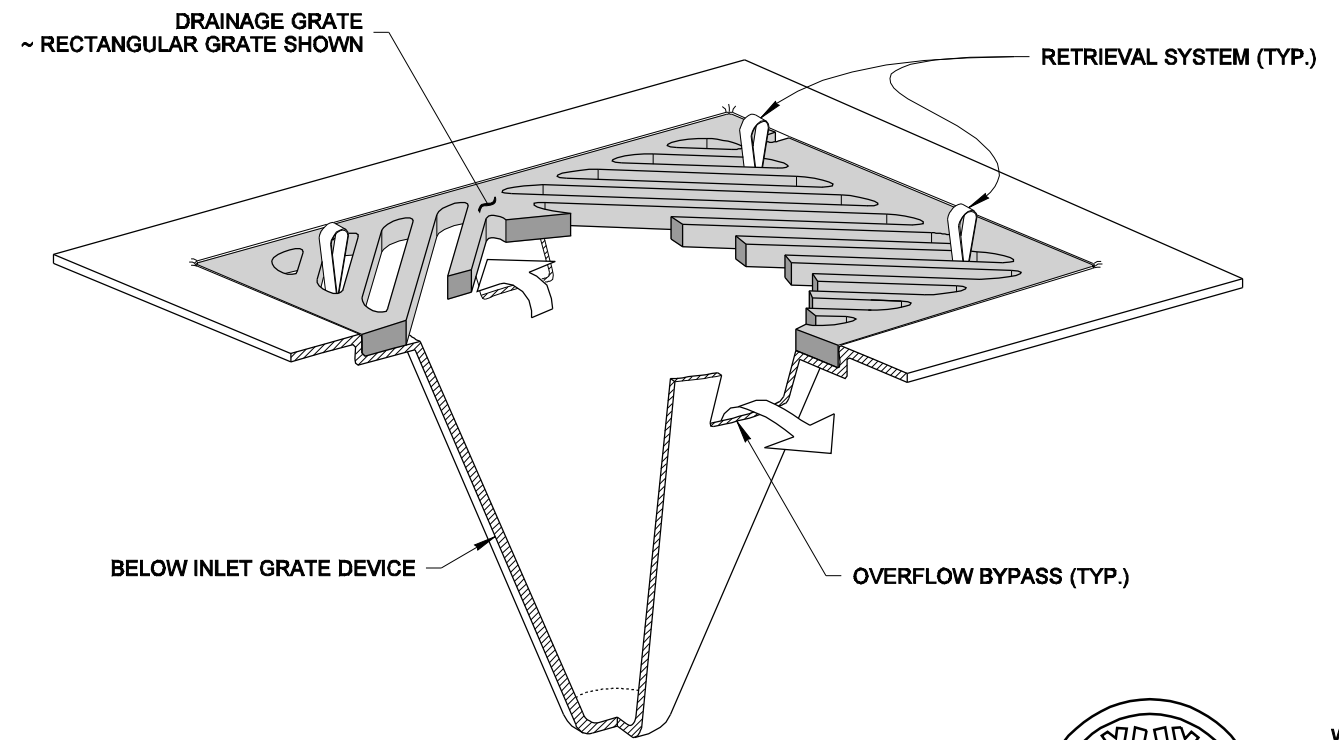

ISOMETRIC VIEW

NOTES

1. Size the Below Inlet Grate Device (BIGD) for the storm water structure it will service.
2. The BIGD shall have a built-in high-flow relief system (overflow bypass).
3. The retrieval system must allow removal of the BIGD without spilling the collected material.
4. Perform maintenance in accordance with Standard Specification 8-01.3(15).

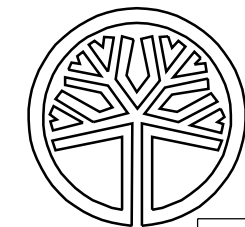

STATE OF WASHINGTON
REGISTERED
LANDSCAPE ARCHITECT

MARK W. MAURER
CERTIFICATE NO. 000598

NOTE: THIS PLAN IS NOT A LEGAL ENGINEERING DOCUMENT BUT AN ELECTRONIC DUPLICATE. THE ORIGINAL, SIGNED BY THE ENGINEER AND APPROVED FOR PUBLICATION, IS KEPT ON FILE AT THE WASHINGTON STATE DEPARTMENT OF TRANSPORTATION. A COPY MAY BE OBTAINED UPON REQUEST.

**STORM DRAIN
INLET PROTECTION
STANDARD PLAN I-40.20-00**

SHEET 1 OF 1 SHEET

APPROVED FOR PUBLICATION

Pasco Bakotich III **09-20-07**
STATE DESIGN ENGINEER DATE



CHANNELIZATION TAPER FORMULA, T_1

$T_1 = WS$ (45 MPH OR MORE) $S =$ SPEED LIMIT (MPH)
 $T_1 = \frac{WS^2}{60}$ (0 TO 40 MPH) $W =$ OFFSET FROM NORMAL CENTER LINE (FT.)
 $T_1 =$ LENGTH OF TAPER (FT.)

NOTES:
 T_1 SHALL BE 50% LARGER WHEN LOCATED IN A CURVE
 T_1 SHALL BE A MINIMUM LENGTH OF 90 FEET

TURN LANE STORAGE LENGTH, P

TO BE DETERMINED BY AN ENGINEERING STUDY
 MIN. --- 100 FEET
 DESIRABLE ----- 125 FEET TO 150+ FEET
 POCKET LENGTHS SHORTER THAN MINIMUM
 BY APPROVAL OF COUNTY ENGINEER

*** ARROW SPACING FOR LEFT- / RIGHT-TURN POCKETS**

POCKET LENGTH (P)		USE	SPACING AS MEASURED TO TAIL OF ARROW
MORE THAN	UP TO		
-	130 FEET	1 ARROW**	1ST ARROW AT START OF POCKET
130 FEET	255 FEET	2 ARROWS**	2ND ARROW AT 50 FEET FROM STOP BAR
255 FEET	-	3 ARROWS**	3RD ARROW CENTERED BETWEEN 1ST & 2ND

**ONLY(S) REQUIRED FOR DROP LANES (SEE CASE C)
 AND FOR "TEE" INTERSECTIONS (SEE CASE E) - SEE SHEET 2 OF 9.

CASE "A" LEFT-TURN POCKET FROM TWO-WAY LEFT-TURN CENTER LINE

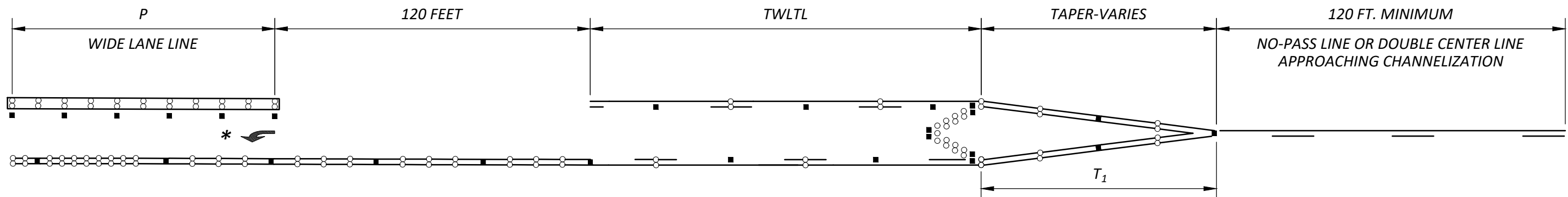

CASE "B" LEFT TURN POCKET FROM TAPER SECTION

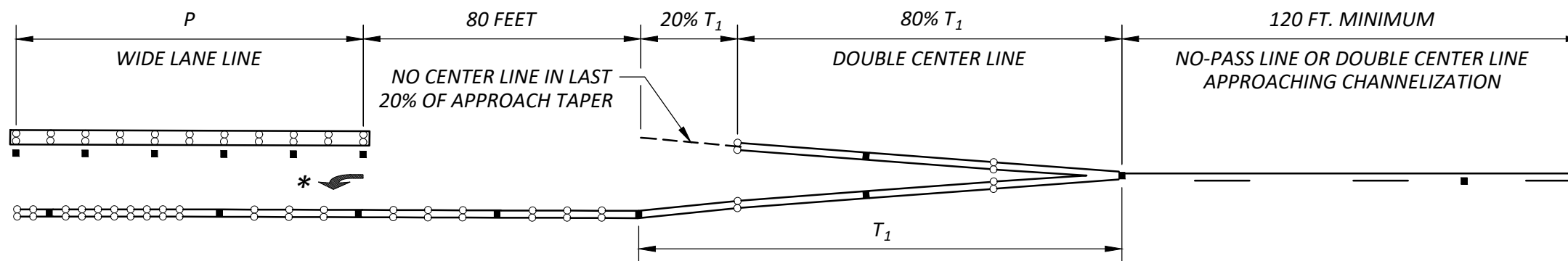

SEE STANDARD DRAWINGS PC.H2.4, PC.H2.5, AND PC.H2.6 FOR RPM LAYOUT
 SEE STANDARD DRAWING PC.H2.9 FOR NOTES AND STRIPING PATTERNS

(NOT TO SCALE)

CASE "C" LEFT- OR RIGHT-TURN DROP LANE FROM TWO THROUGH LANES

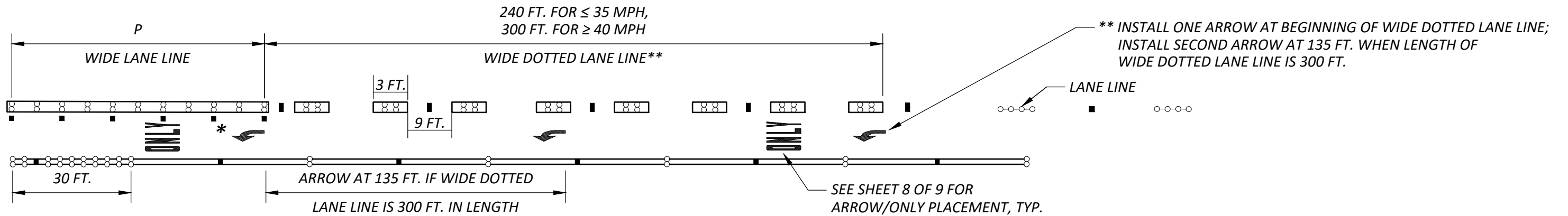

CASE "D" RIGHT-TURN ADD LANE

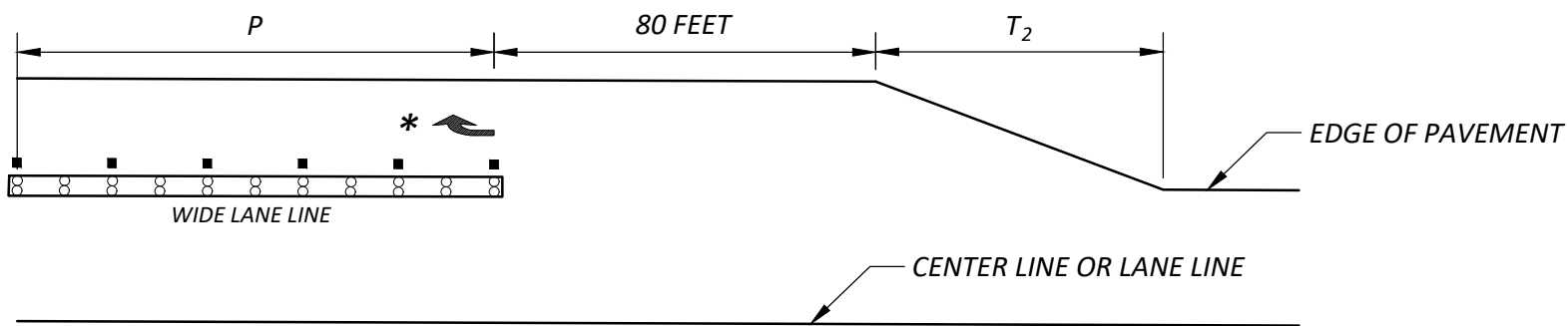

CHANNELIZATION TAPER FORMULA, T_2

$T_2 = 0.15 WS$ (40 MPH AND GREATER) $S =$ SPEED LIMIT (MPH)
 $T_2 = 60$ FT. (0 TO 35 MPH) $W =$ ADD LANE WIDTH (FEET)
 $T_2 =$ LENGTH OF TAPER (FEET)

* FOR NUMBER AND SPACING OF ARROW MARKINGS FOR LEFT/RIGHT TURN POCKETS, SEE SHEET 1 OF 9

CASE "E" TEE INTERSECTIONS WITH A LEFT- AND RIGHT-TURN LANE

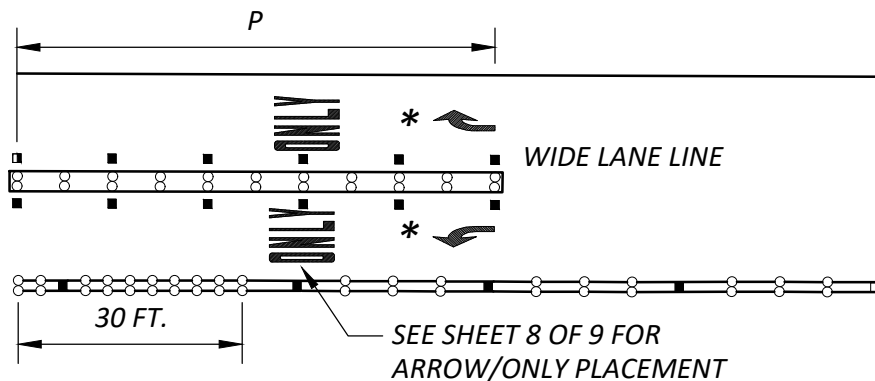

SEE STANDARD DRAWINGS PC.H2.4, PC.H2.5, AND PC.H2.6 FOR RPM LAYOUT
 SEE STANDARD DRAWING PC.H2.9 FOR NOTES AND STRIPING PATTERNS

(NOT TO SCALE)



Pierce County

Planning & Public Works
 Office of the County Engineer

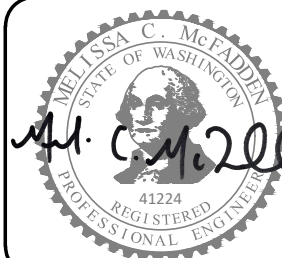

APPROVED BY:
 COUNTY ENGINEER

10/17/2022

DATE

PAVEMENT MARKINGS

SHEET 2 OF 9

STANDARD DRAWING PC.H2.2

TWO-WAY LEFT-TURN LANE ARROW PLACEMENT

SEGMENT LENGTH, D	# OF ARROW SETS	LOCATION OF CENTER OF ARROW SET
0 FT. - 100 FT.	0	NONE
101 FT. - 300 FT.	1	
301 FT. - 500 FT.	2	
501 FT. - 850 FT.	3	
851 FT. - 1200 FT.	4	
1201 FT. - 1550 FT.	5	** SPACE BALANCE OF SETS EVENLY OVER THE REMAINDER OF THE SEGMENT.
OVER 1550 FT.	$\frac{D+200}{350}$	ROUND UP TO THE NEAREST WHOLE NUMBER

CASE "F" TWO-WAY LEFT-TURN LANE AT DRIVEWAY OR ROADWAY

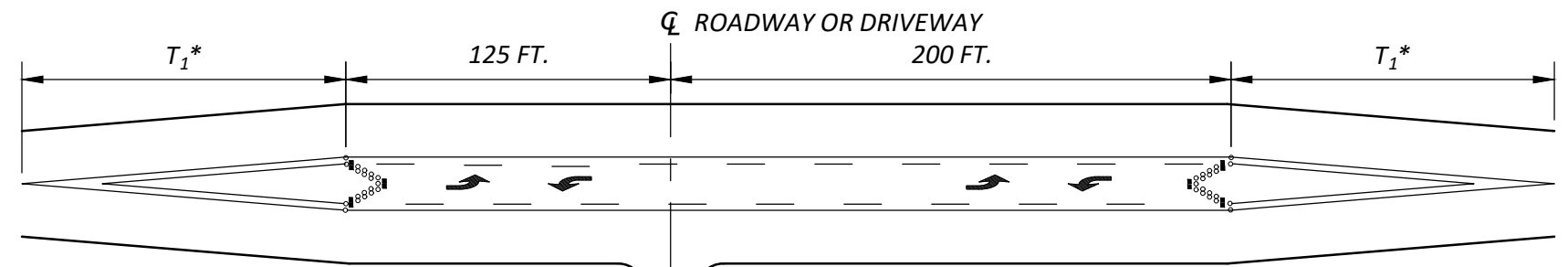

NOTES: -MINIMUM SEGMENT LENGTHS SHOWN
-BREAK STRIPING FOR PUBLIC ROADS

* WHEN CONSTRUCTING NEW TWLTL NEAR EXISTING TWLTL OR LEFT-TURN LANE, WIDEN ROAD AND CONNECT THE TWLTLs WHEN THE DISTANCE FROM THE END OF ONE CENTER LINE TAPER TO THE BEGINNING OF THE NEXT CENTER LINE TAPER IS 125 FEET OR LESS. SEE STANDARD DRAWING PC.H2.1 FOR TAPER LENGTH (T_1) INFORMATION.

MEASUREMENT OF SEGMENT LENGTH AND END TREATMENT EXAMPLES:

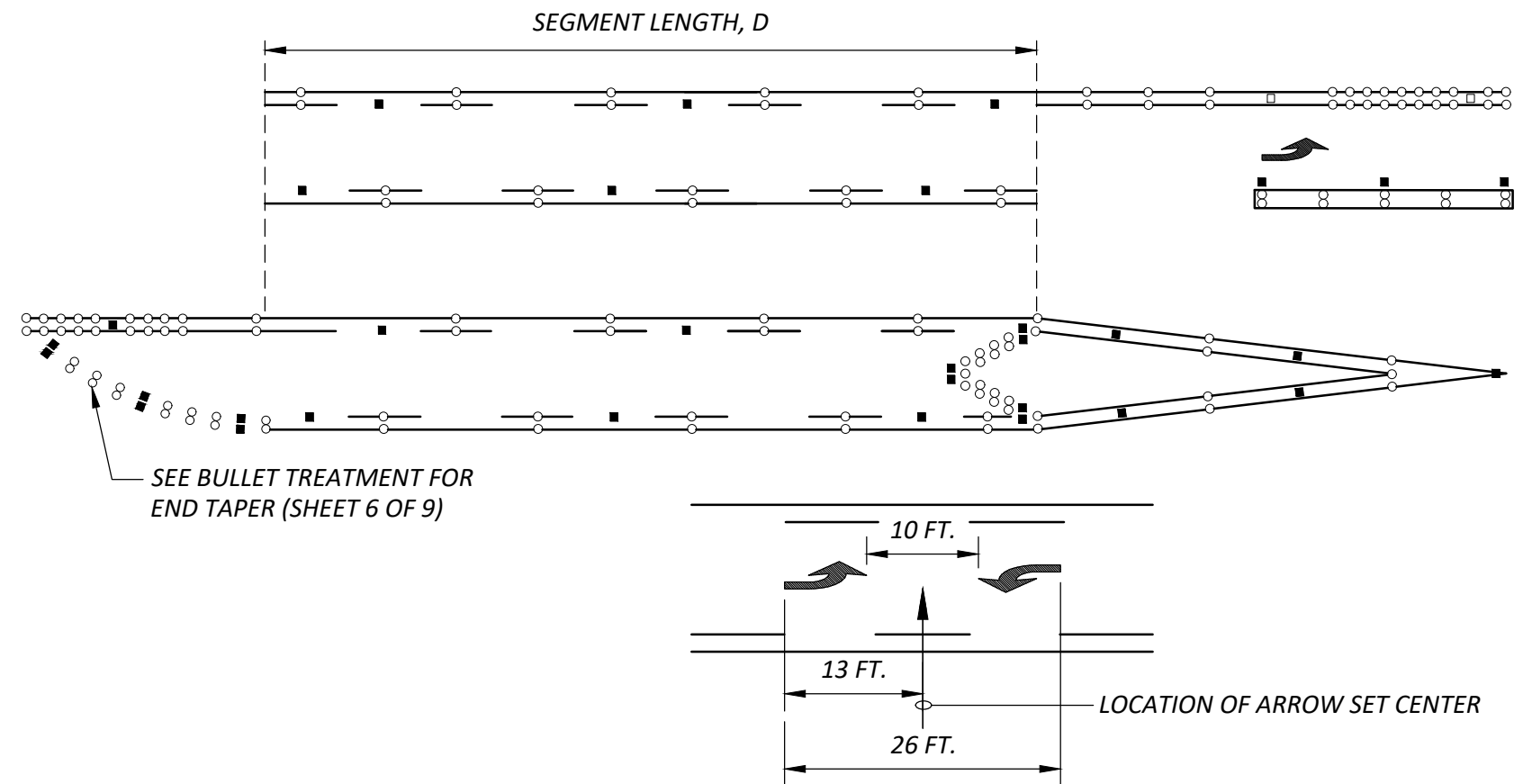

SEE BULLET TREATMENT FOR END TAPER (SHEET 6 OF 9)

SEE STANDARD DRAWINGS PC.H2.4, PC.H2.5, AND PC.H2.6 FOR RPM LAYOUT
SEE STANDARD DRAWING PC.H2.9 FOR NOTES AND STRIPING PATTERNS

(NOT TO SCALE)



Pierce County

Planning & Public Works
Office of the County Engineer



APPROVED BY:
COUNTY ENGINEER

10/17/2022

DATE

PAVEMENT MARKINGS

SHEET 3 OF 9

STANDARD DRAWING PC.H2.3

**RPM LAYOUT FOR TWO-LANE ROADS
(NARROW AND WIDE PATTERN)**

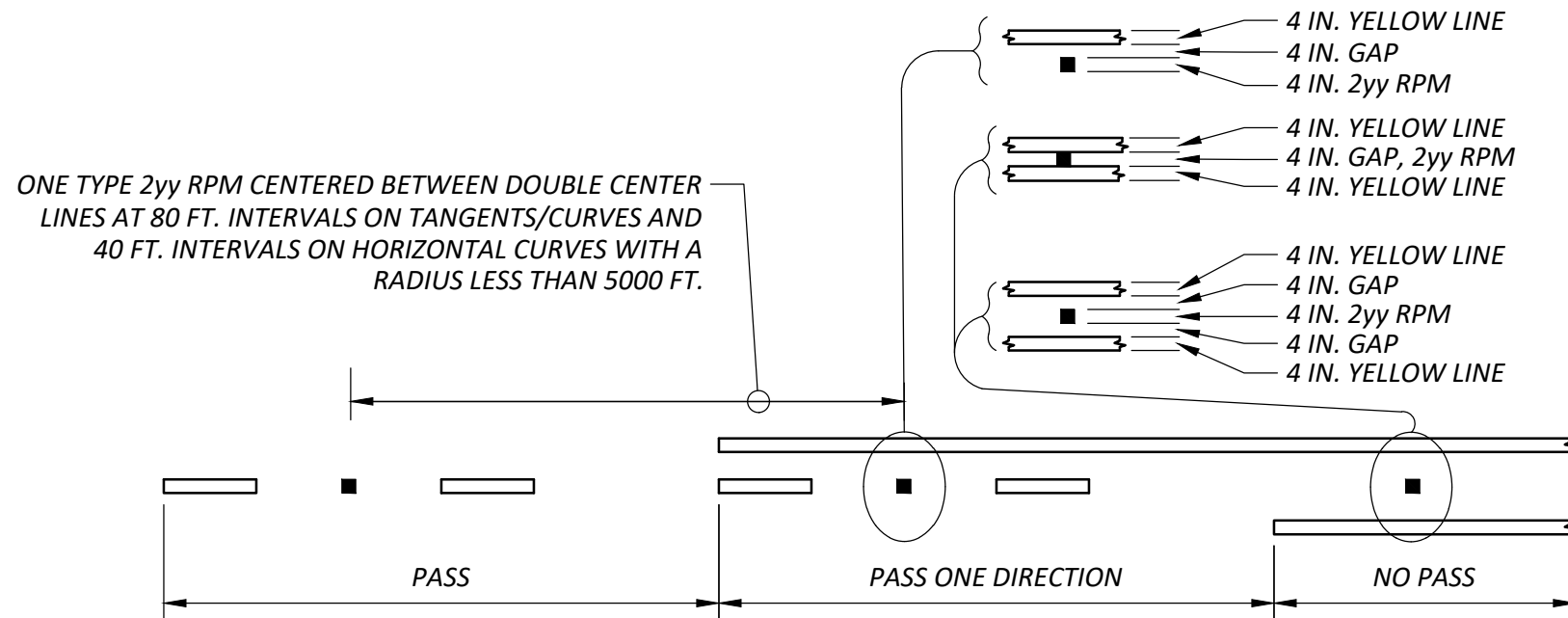

RPM LAYOUT FOR WIDE LANE LINE

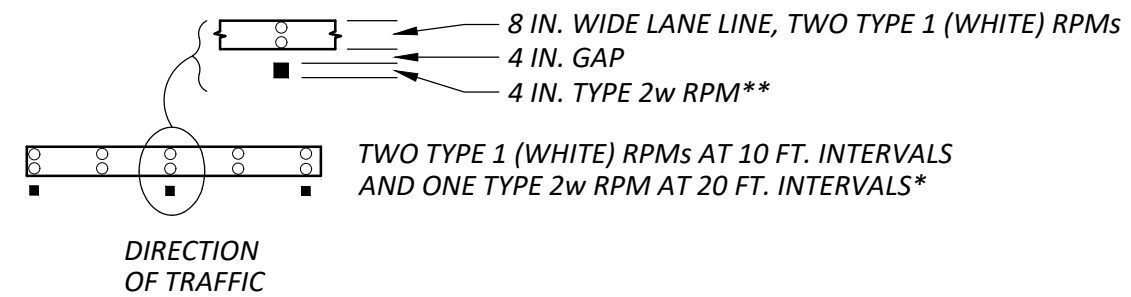

RPM LAYOUT FOR WIDE DOTTED LANE LINE

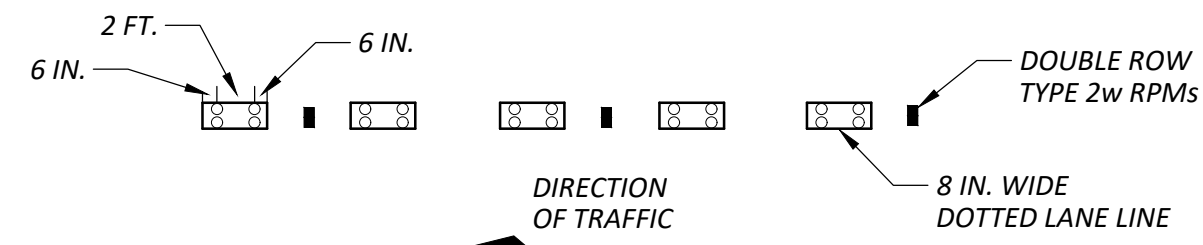

WIDE DOTTED LANE LINE WITH TWO DOUBLE ROWS OF TYPE 1 (WHITE) RPMs EQUALLY SPACED. CENTERED BETWEEN EVERY SECOND WIDE DOTTED LANE LINE INSTALL DOUBLE ROW OF TYPE 2w RPMs.*

**RPM LAYOUT FOR MULTI-LANE ROADS
(NARROW PATTERN)**

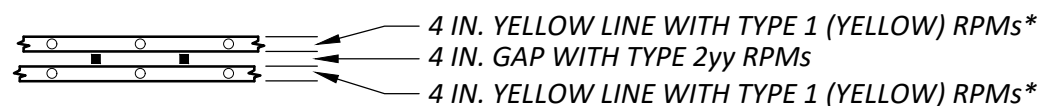

INSTALL TYPE 1 (YELLOW) RPMs, ONE ON EACH LINE WITH A TYPE 2yy RPM CENTERED BETWEEN BOTH LINES AND TYPE 1 SETS. RPMs SHALL BE SPACED AT 80 FT. INTERVALS ON TANGENTS/CURVES AND 40 FT. INTERVALS ON HORIZONTAL CURVES WITH RADII LESS THAN 5000 FT.

RPM LAYOUT FOR PAINTED LANE LINES

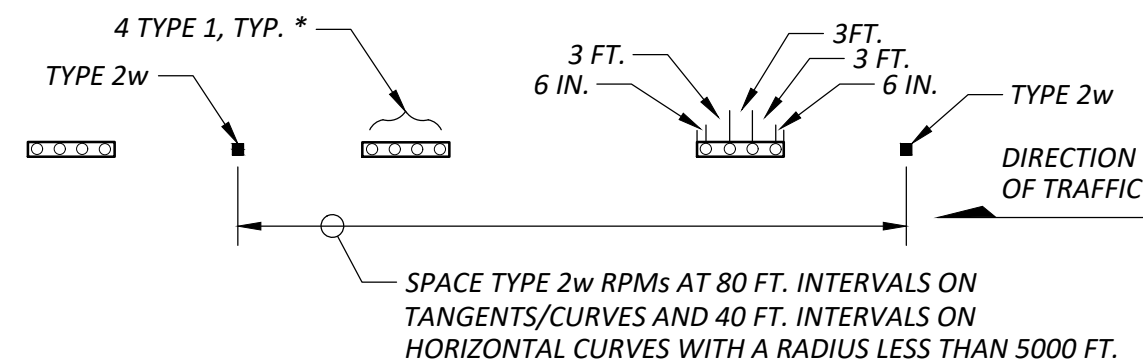

* OMIT TYPE 1 RPMs ON TYPE D STRIPING.

** TYPE 2w RPM GOES IN THE TURN LANE. IN THE CASE OF SIDE-BY-SIDE TURN LANES, BOTH LANES SHALL HAVE TYPE 2w RPMs.

**SEE STANDARD DRAWING PC.H2.9
FOR NOTES AND STRIPING PATTERNS**

(NOT TO SCALE)

RPM LAYOUT FOR TURN LANES

LEFT-TURN LANE FROM TAPER OR TWO-WAY LEFT-TURN LANE

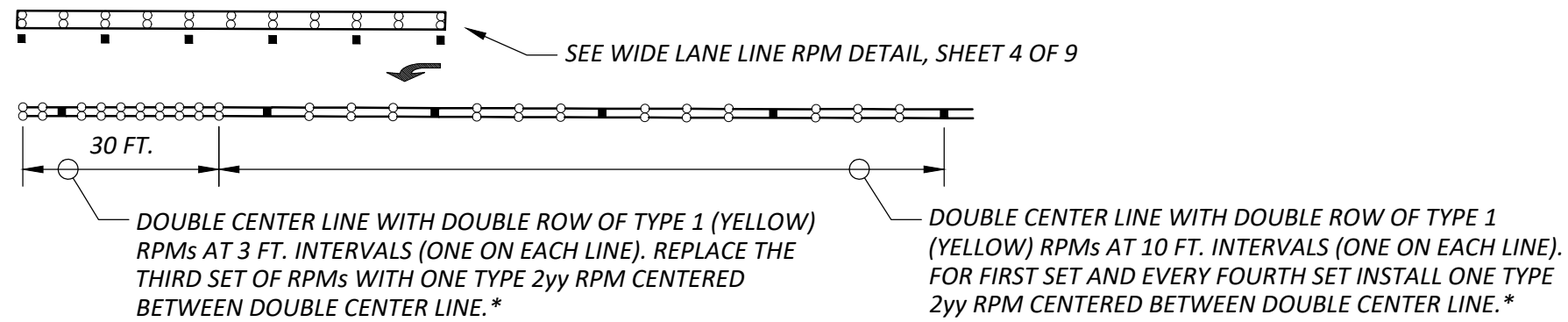

TEE INTERSECTIONS WITH A LEFT- AND RIGHT-TURN LANE

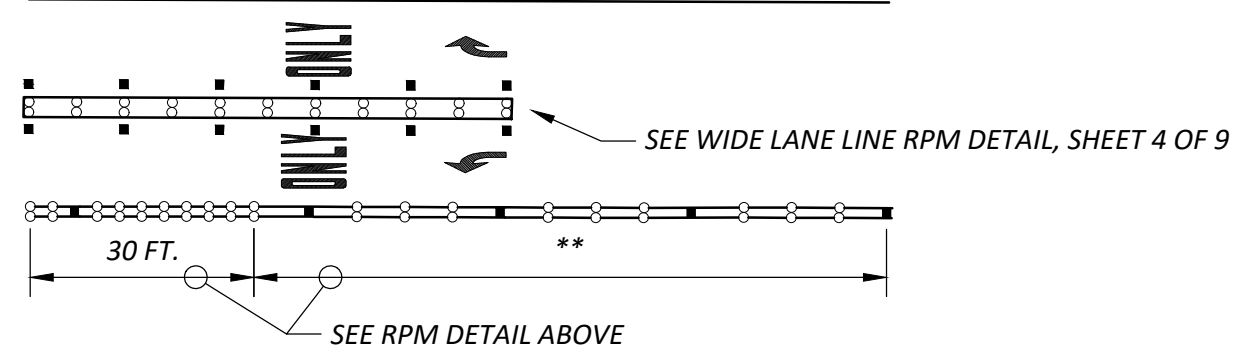

DROP LANE FROM TWO THROUGH LANES

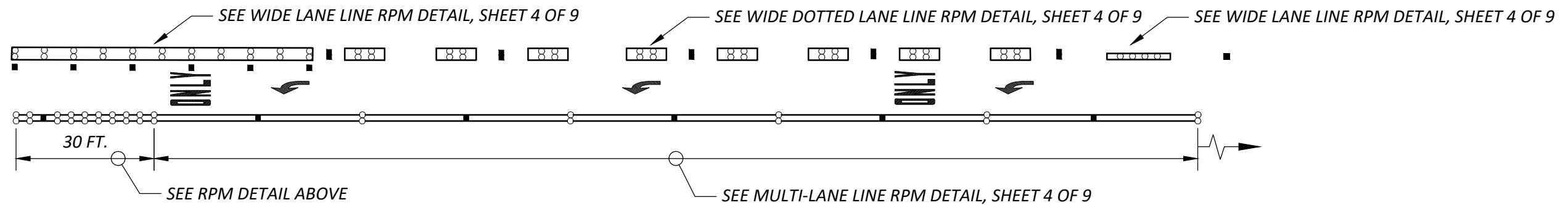

* OMIT TYPE 1 RPMs ON TYPE D STRIPING.

** THIS RPM PATTERN APPLIES 30 FT. FROM THE STOP LINE TO CENTER LINE TAPER AND 90 FT. IF NO CENTER LINE TAPER.

SEE STANDARD DRAWING PC.H2.9 FOR NOTES AND STRIPING PATTERNS

(NOT TO SCALE)



Pierce County

Planning & Public Works
Office of the County Engineer

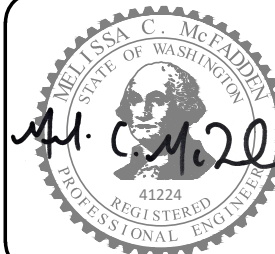

APPROVED BY:
COUNTY ENGINEER

10/17/2022

DATE

PAVEMENT MARKING

SHEET 5 OF 9

STANDARD DRAWING PC.H2.5

RPM LAYOUT FOR TWO-WAY LEFT-TURN LANE

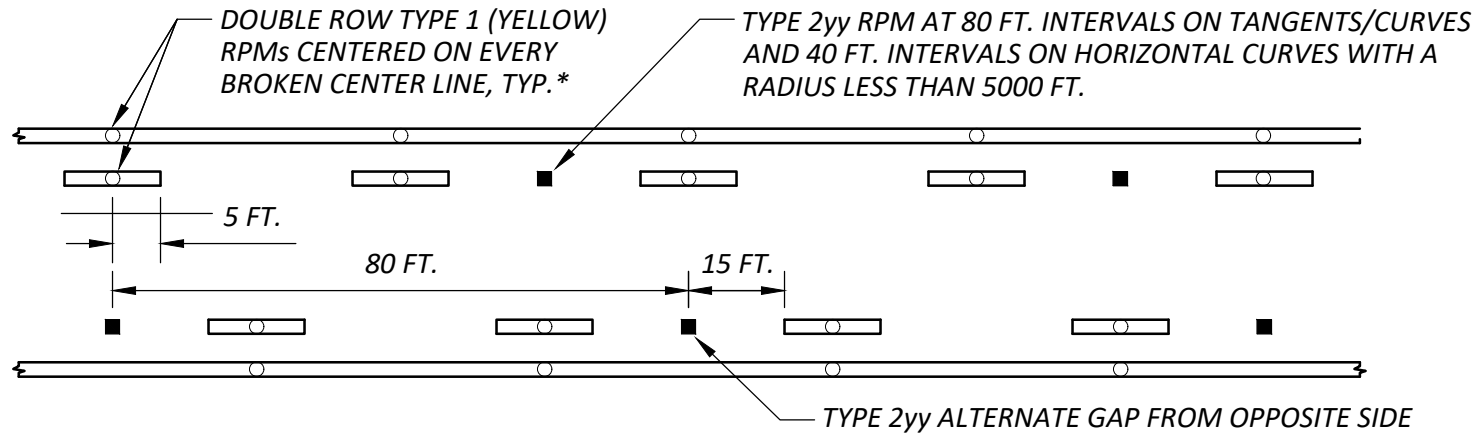

BULLET TREATMENT FOR END OF TAPER

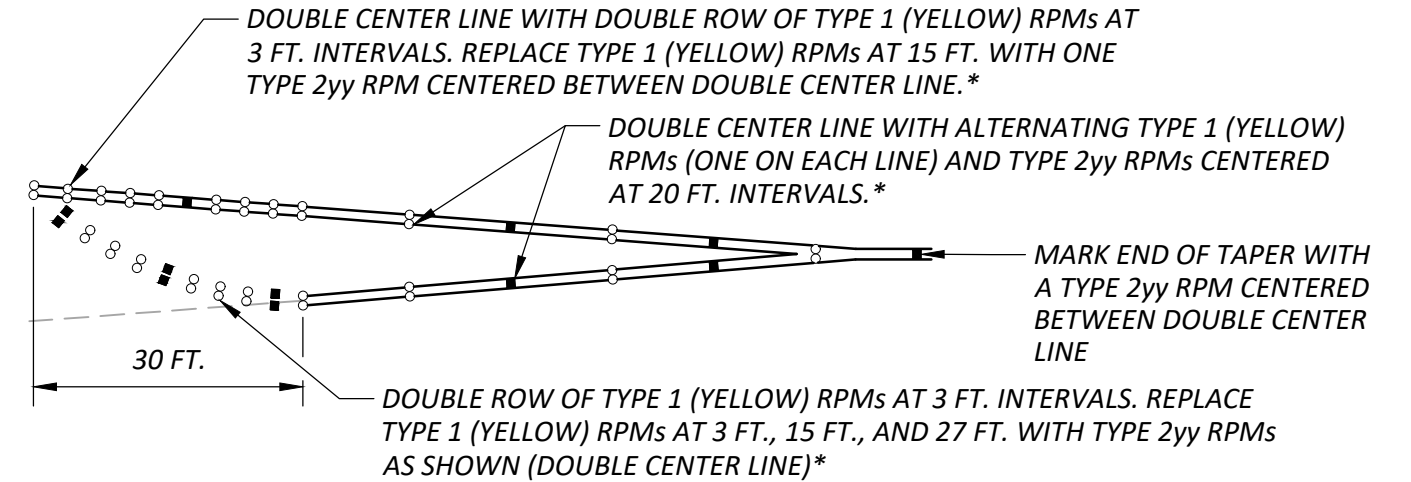

**RPM LAYOUT FOR END OF TAPER/
BEGINNING OF TWO-WAY LEFT-TURN LANE**

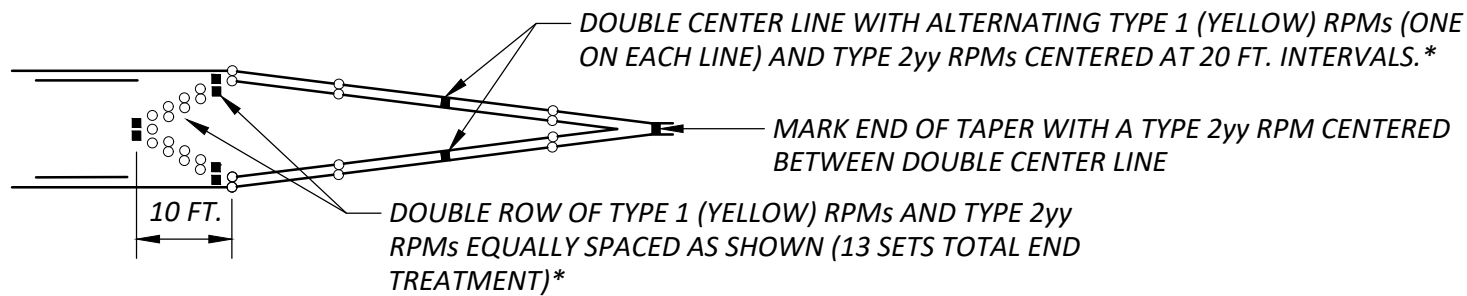

RAISED PAVEMENT MARKERS (RPMs)

TYPE 1	NON-REFLECTIVE	YELLOW OR WHITE
TYPE 2yy	REFLECTIVE FACE BOTH SIDES	YELLOW AND YELLOW
TYPE 2w	REFLECTIVE FACE ONE SIDE, APPROACH DIRECTION	WHITE

* OMIT TYPE 1 RPMs ON TYPE D STRIPING.

SEE STANDARD DRAWING PC.H2.9 FOR NOTES AND STRIPING PATTERNS

(NOT TO SCALE)



Pierce County

Planning & Public Works
Office of the County Engineer

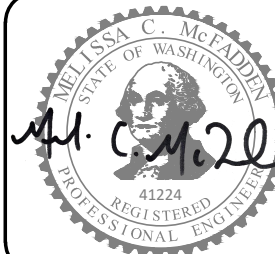

APPROVED BY:
COUNTY ENGINEER

M. C. McFadden

10/17/2022

DATE

PAVEMENT MARKINGS

SHEET 6 OF 9

STANDARD DRAWING PC.H2.6

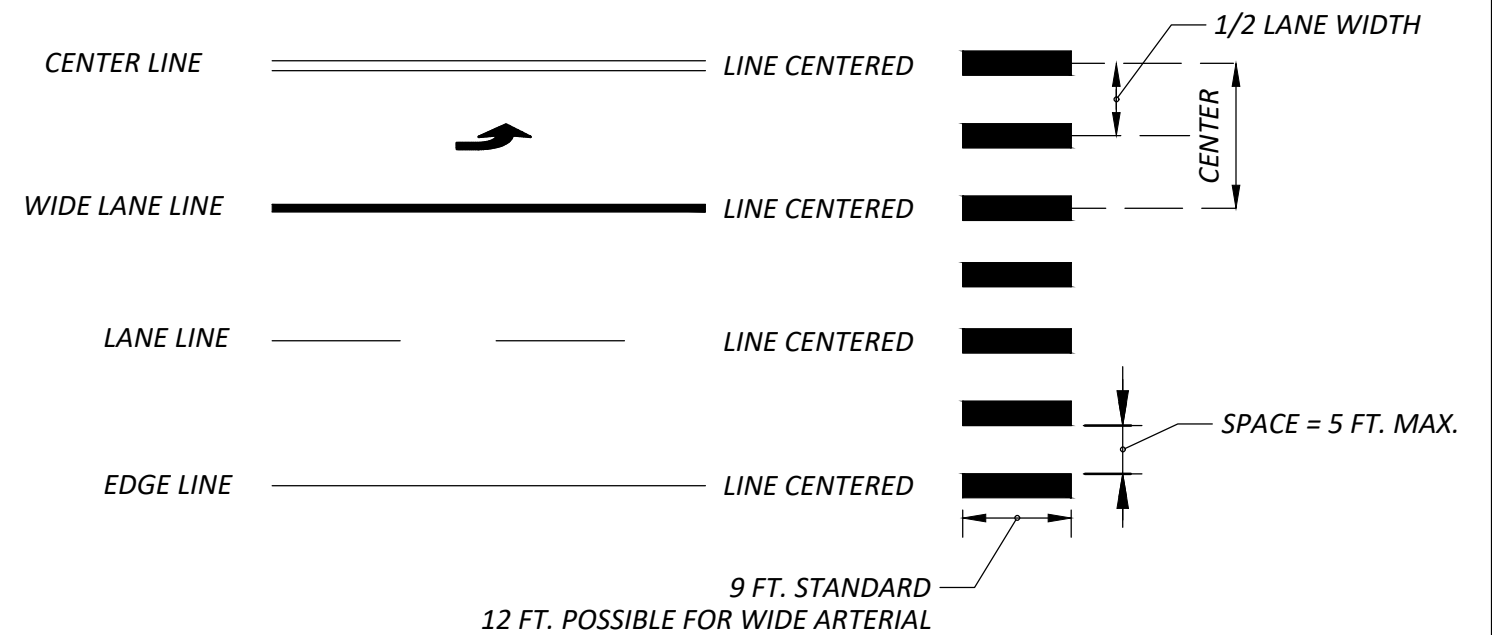
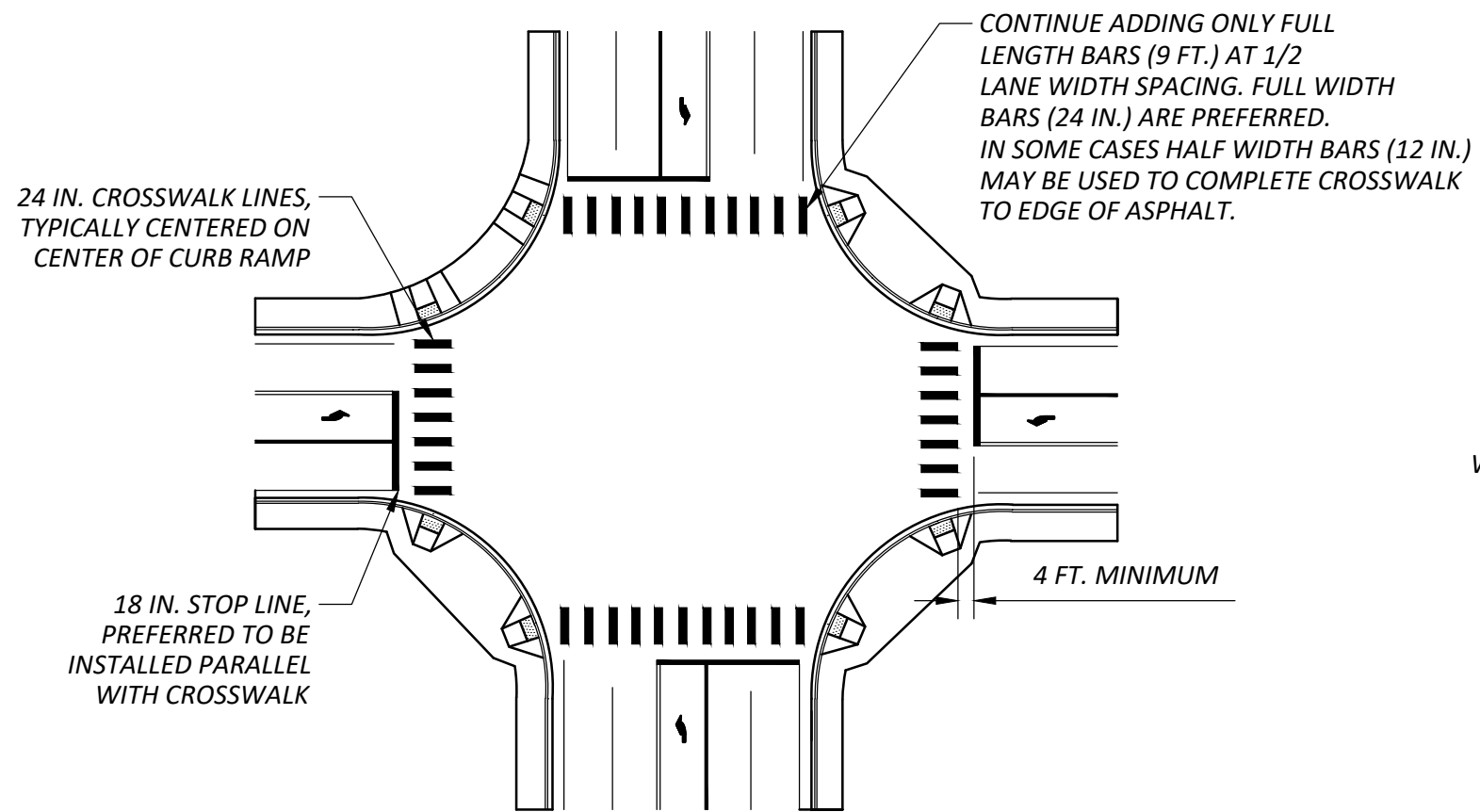

MARKED CROSSWALKS

SEE STANDARD DRAWING PC.H2.9 FOR NOTES

(NOT TO SCALE)



Pierce County

Planning & Public Works
Office of the County Engineer



APPROVED BY:
COUNTY ENGINEER

M. C. McFadden

10/17/2022

DATE

PAVEMENT MARKINGS

SHEET 7 OF 9

STANDARD DRAWING PC.H2.7

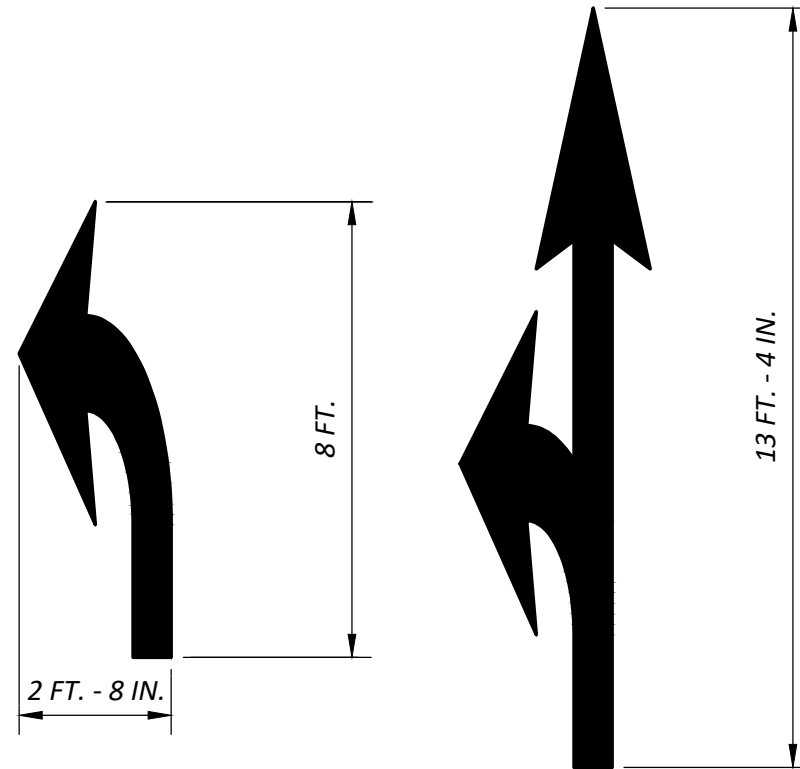

* "ONLY" TO BE USED IN CASE "C" CONDITION (SEE PAVEMENT MARKINGS SHEET 2 OF 9) AND CASE "E" CONDITION.

PATTERN OF ARROW/ONLY COMBINATIONS STARTING AT THE ENTRANCE INTO THE POCKET IS AS FOLLOWS:
 ONE ARROW = ARROW/ONLY
 TWO ARROWS = ARROW/ONLY/ARROW
 THREE ARROWS = ARROW/ONLY/ARROW/ONLY/ARROW

SPACE ARROWS IN THE POCKET AS SHOWN ON SHEET 1 OF 9.

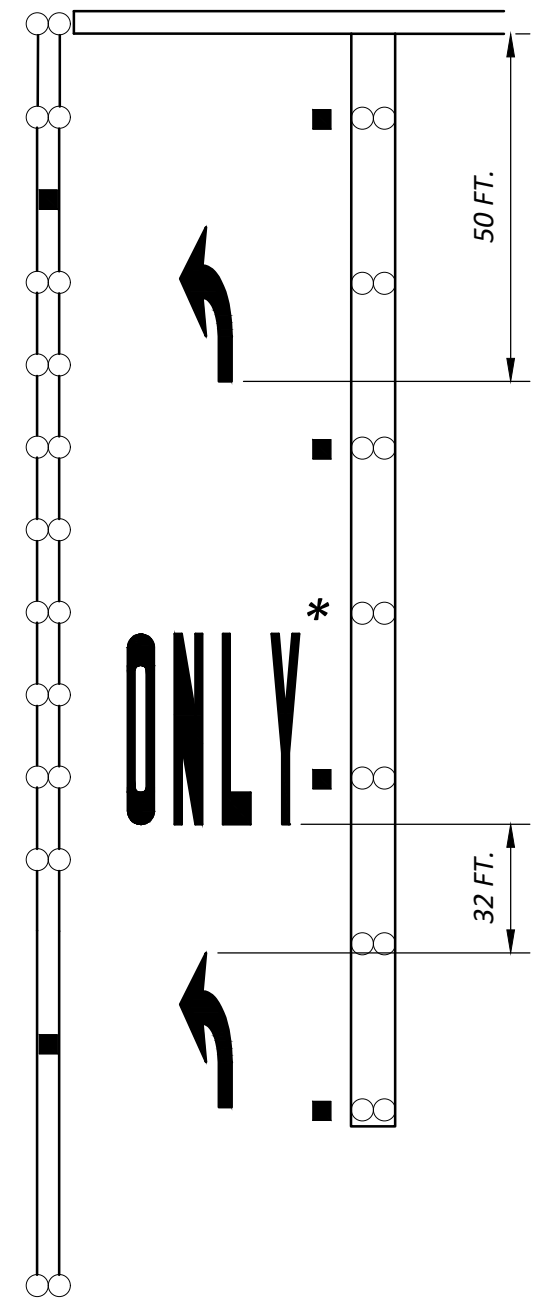

TRAFFIC ARROW AND ONLY DETAILS

ARROW / ONLY PLACEMENT

NOTES:

- 1) CENTERED IN LANE, TYPICAL.
- 2) USE TYPE B PREFORMED FUSED THERMOPLASTIC, SEE SHEET 9 OF 9.
- 3) IF PAINTED MARKINGS ARE SPECIFIED FOR USE, CONTACT PIERCE COUNTY TRAFFIC OPERATIONS AT (253) 798-8000 FOR TEMPLATES.

**SEE STANDARD DRAWINGS PC.H2.4, PC.H2.5, AND PC.H2.6 FOR RPM LAYOUT
 SEE STANDARD DRAWING PC.H2.9 FOR NOTES AND STRIPING PATTERNS**

(NOT TO SCALE)

NOTES:

1) GENERAL - ALL PAVEMENT MARKINGS SHALL CONFORM TO THE REQUIREMENTS OF THE MANUAL ON UNIFORM TRAFFIC CONTROL DEVICES (MUTCD), AND TO THE WASHINGTON STATE DEPARTMENT OF TRANSPORTATION STANDARD SPECIFICATIONS FOR ROAD, BRIDGE, AND MUNICIPAL CONSTRUCTION, AS ADOPTED BY PIERCE COUNTY. ALL STRIPING SHALL BE PAINTED USING WATER-BASED MATERIAL UNLESS OTHERWISE SPECIFIED IN THE PLANS. ALL ARROWS, ONLYs, CORSSWALK LINES, STOP LINES, AND OTHER MARKINGS SHALL BE TYPE B PREFORMED THERMOPLASTIC, AS APPROVED BY THE COUNTY TRAFFIC ENGINEER. ALL TYPE B PAVEMENT MARKING MATERIAL SHALL HAVE FACTORY APPLIED REFLECTIVE BEADS AND HEAT INDICATORS. WHEN SPECIFIED ON THE PLANS, ALL LONG LINES SHALL BE PLASTIC TYPE D-3 OR D-4.

2) CENTER LINES - CENTER LINES, NO-PASS LINES, AND DOUBLE CENTER LINES, AS WARRANTED, SHALL BE USED ON ALL ARTERIALS AND ON ALL UNDIVIDED PAVEMENTS OF THREE OR MORE LANES.

DOUBLE CENTER LINE SHALL HAVE 4 INCHES BETWEEN LINES FOR MULTI-LANE ROADWAYS, COLLECTOR ARTERIAL, WHERE LEFT-TURN CHANNELIZATION IS PRESENT, AND ON NARROWER ROADWAYS WITH 10-FOOT WIDE LANES OR LESS. DOUBLE CENTER LINE SHALL HAVE 12 INCHES BETWEEN LINES ON MAJOR AND SECONDARY ARTERIALS, WHERE NONE OF THE ABOVE LISTED CONDITIONS ARE PRESENT.

INSTALL CENTER LINE RPMs IN ACCORDANCE WITH SHEETS 4, 5, AND 6 OF 9.

3) LANE LINE - LANE LINES SHALL BE USED ON MULTI-LANE ROADS. INSTALL RPMs IN ACCORDANCE WITH SHEETS 4, 5, AND 6 OF 9.

4) EDGE LINE - EDGE LINES SHALL BE USED UNDER THE FOLLOWING CIRCUMSTANCES AND SHALL BE CARRIED THROUGH PRIVATE DRIVEWAYS AND PRIVATE ROAD APPROACHES:

A) ON ALL MAJOR ARTERIALS, WHEN MINIMUM 10-FOOT LANE WIDTHS CAN BE PROVIDED AND NO CONTINUOUS CURBING EXISTS ALONG THE ARTERIAL.

B) ON ALL URBAN SECONDARY ARTERIALS AND ALL RURAL SECONDARY ARTERIALS THAT HAVE A POSTED SPEED LIMIT OF 40 MPH OR GREATER OR AN AADT > 3,000, WHEN MINIMUM 10-FOOT LANE WIDTHS CAN BE PROVIDED AND NO CONTINUOUS CURBING EXISTS ALONG THE ARTERIAL.

C) ON ALL COLLECTOR ARTERIALS THAT HAVE AN AADT > 3,000, WHEN MINIMUM 10-FOOT LANE WIDTHS CAN BE PROVIDED AND NO CONTINUOUS CURBING EXISTS ALONG THE ARTERIAL.

D) ON ALL PAVEMENT WIDTH TRANSITIONS. OMIT IF ADJACENT TO CURBING.

E) ON ALL ARTERIALS WHERE IT IS DESIRABLE TO REDUCE DRIVING ON PAVED SHOULDERS.

5) STOP LINE - STOP LINES SHALL BE USED UNDER THE FOLLOWING CIRCUMSTANCES AND SHALL BE CARRIED ACROSS ALL APPROACH LANES THAT ARE REQUIRED TO STOP:

A) ON ALL APPROACHES TO SIGNALIZED INTERSECTIONS.

B) ON ALL APPROACHES TO MULTI-WAY STOP INTERSECTIONS.

C) ON ALL APPROACHES WHERE CHANNELIZATION EXISTS.

6) CROSSWALK LINE - CROSSWALK LINES SHALL HAVE A SLIP-RESISTANT TREATMENT. THEY SHALL BE USED AT STOP-CONTROLLED INTERSECTIONS, WHEN APPROVED BY THE COUNTY ENGINEER, AT ALL SIGNALIZED INTERSECTIONS, AND AT COUNTY ENGINEER-APPROVED MID-BLOCK CROSSINGS AND UNCONTROLLED CROSSINGS.

7) REMOVAL - ALL EXISTING PAVEMENT MARKINGS THAT ARE IN CONFLICT WITH NEW PAVEMENT MARKINGS SHALL BE REMOVED.

8) DEFINITIONS - (NOTE: PROFILED PLASTIC LINES (TYPE D) SHALL CONFORM TO WSDOT STANDARD PLAN M-20.20-XX UNLESS OTHERWISE NOTED)

A) CENTER LINE - 4-INCH BROKEN YELLOW, 10-FOOT LINE, 30-FOOT GAP (NOT PROFILED IF TYPE D)

B) NO-PASS LINE - 4-INCH SOLID YELLOW / 4-INCH GAP / 4-INCH BROKEN YELLOW, 10-FOOT LINE, 30-FOOT GAP (NOT PROFILED IF TYPE D)

C) DOUBLE CENTER LINE - 4-INCH SOLID YELLOW / 4-INCH OR 12-INCH GAP / 4-INCH SOLID YELLOW (NOT PROFILED IF TYPE D)

D) TWO-WAY LEFT-TURN CENTER LINE - 4-INCH SOLID YELLOW / 4-INCH GAP / 4-INCH BROKEN YELLOW, 10-FOOT LINE, 30-FOOT GAP (NOT PROFILED IF TYPE D)

E) LANE LINE - 4-INCH BROKEN WHITE, 10-FOOT LINE, 30-FOOT GAP (PROFILED IF TYPE D)

F) EDGE LINE - 4-INCH SOLID YELLOW OR WHITE (NOT PROFILED IF TYPE D)

G) WIDE LANE LINE - 8-INCH SOLID WHITE (PROFILED IF TYPE D)

H) WIDE DOTTED LANE LINE - 8-INCH DOTTED WHITE, 3-FOOT LINE, 9-FOOT GAP (PROFILED IF TYPE D)

I) DOTTED EXTENSION LINE - 4-INCH DOTTED WHITE OR YELLOW, 2-FOOT LINE, 6-FOOT GAP (NOT PROFILED IF TYPE D)

J) STOP LINE - 18-INCH WHITE, PLASTIC

K) CROSSWALK LINE - 24-INCH WIDE, 9-FEET LONG, UNLESS OTHERWISE NOTED, PLASTIC

(NOT TO SCALE)



Pierce County

Planning & Public Works
Office of the County Engineer



APPROVED BY:
COUNTY ENGINEER

10/17/2022

DATE

PAVEMENT MARKINGS

SHEET 9 OF 9

STANDARD DRAWING PC.H2.9

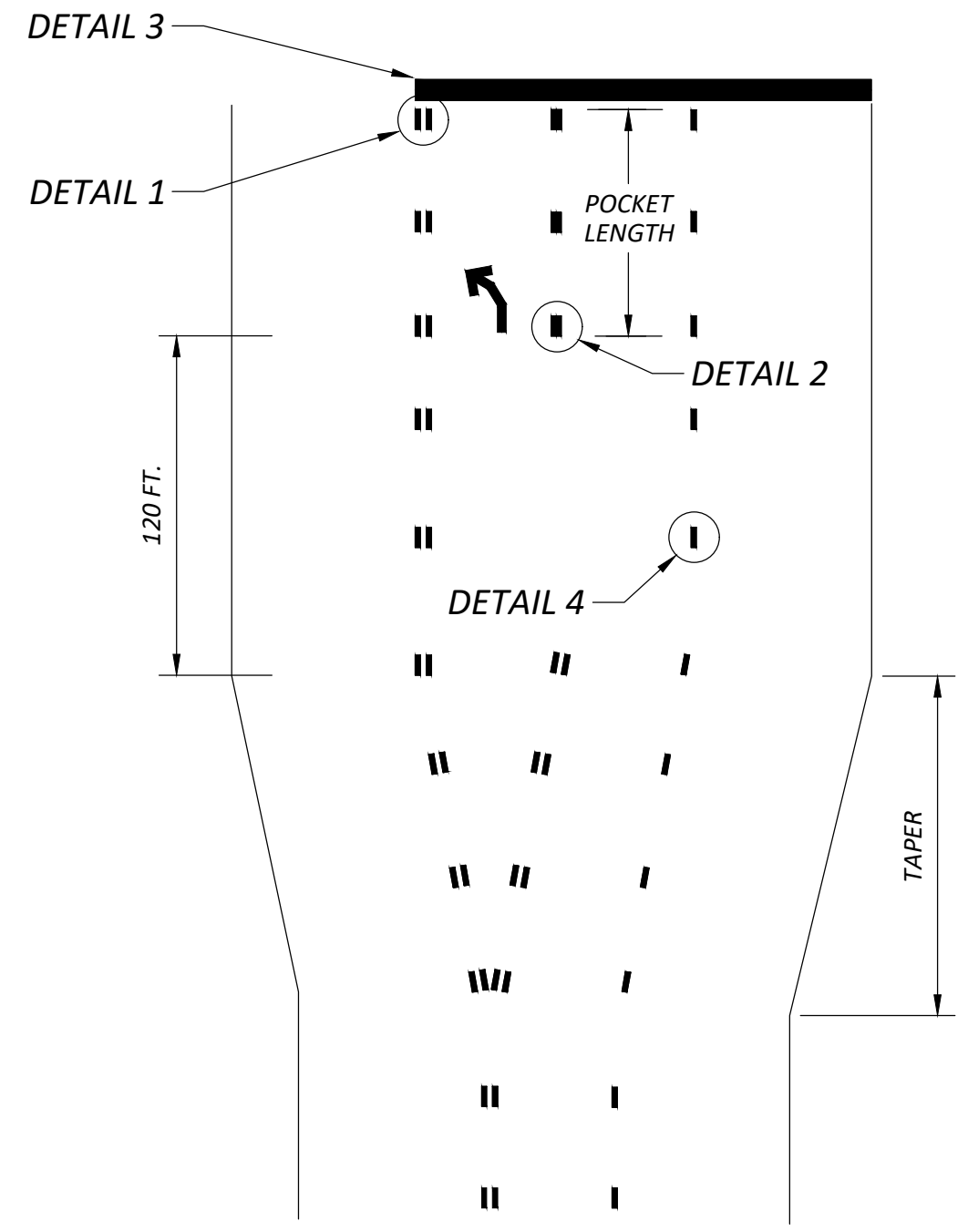
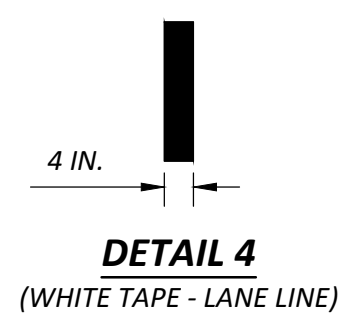
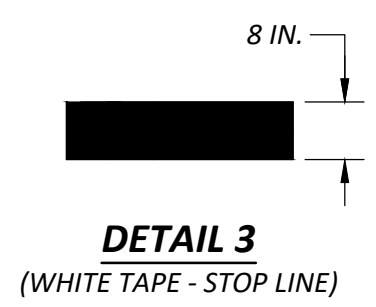
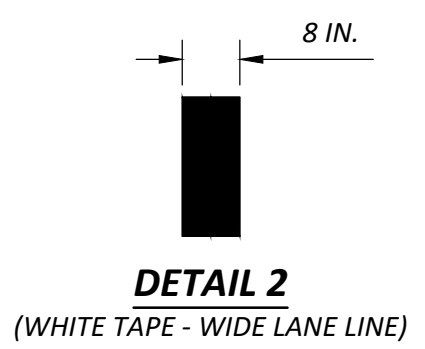
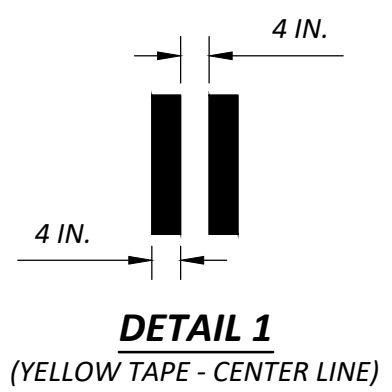

NOTES:

- 1) TEMPORARY TAPE FOR LANE LINES AND DOUBLE CENTER LINES SHALL BE BASED ON A 40-FOOT UNIT CONSISTING OF A 4-FOOT LINE WITH A 36-FOOT GAP.
- 2) TEMPORARY TAPE FOR WIDE LANE LINES SHALL BE BASED ON A 20-FOOT UNIT CONSISTING OF A 4-FOOT WHITE LINE WITH A 16-FOOT GAP AND 8 INCHES WIDE.
- 3) ALL TEMPORARY STOP LINES SHALL BE CONTINUOUS ACROSS THE APPROACH LANES OF TRAFFIC WHERE THEY CURRENTLY EXISTED PRIOR TO WORK. STOP LINES SHALL CONSIST OF 2 ROWS OF 4-INCH WIDE TAPE.
- 4) TURN ARROWS SHALL BE A MINIMUM OF 6 FEET IN LENGTH.
- 5) TAPER AS REQUIRED BASED ON SPEED AND WIDTH OF WIDENING FROM CENTER LINE.
- 6) FOR TWO-WAY LEFT-TURN LANES, USE DOUBLE TEMPORARY CENTER LINE.
- 7) IF EDGE LINE IS REQUIRED, TEMPORARY TAPE SHALL BE A SOLID 4-INCH WHITE UNBROKEN LINE.

(NOT TO SCALE)

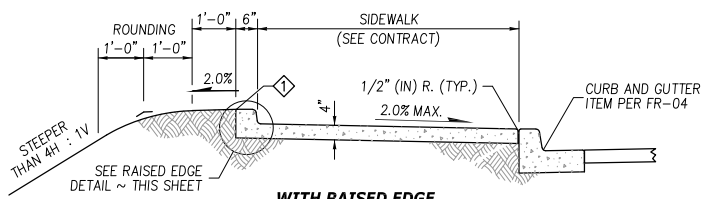

WITH RAISED EDGE

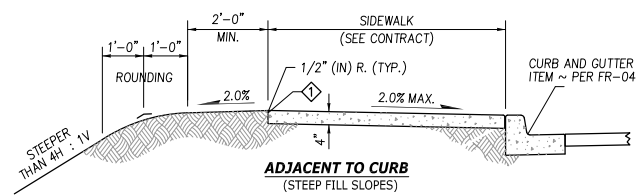

**ADJACENT TO CURB
(STEEP FILL SLOPES)**

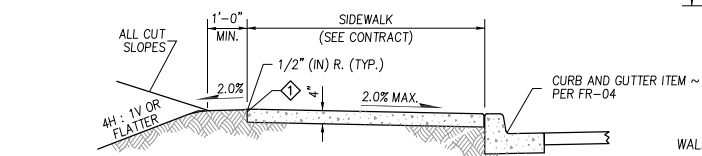

ADJACENT TO CURB

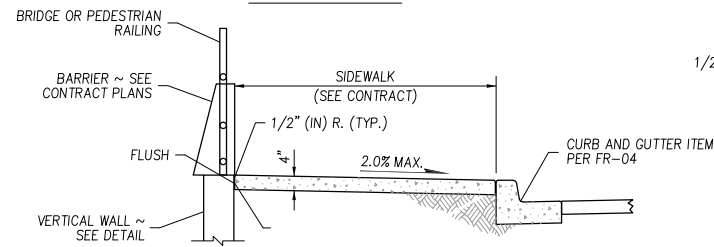

ADJACENT TO CURB AND RAILING OR WALL

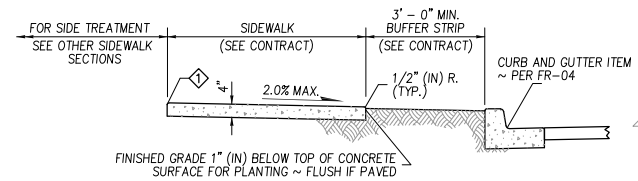

ADJACENT TO BUFFER STRIP

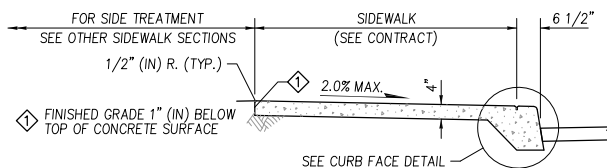

**MONOLITHIC CEMENT CONCRETE
CURB AND SIDEWALK**

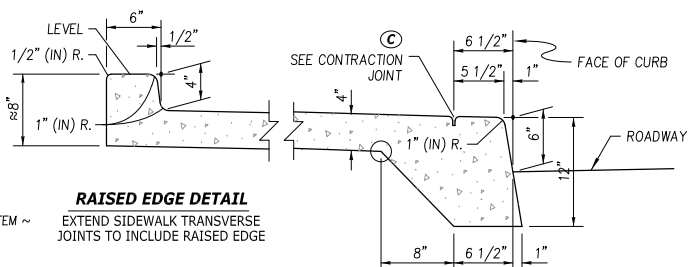

RAISED EDGE DETAIL
EXTEND SIDEWALK TRANSVERSE JOINTS TO INCLUDE RAISED EDGE

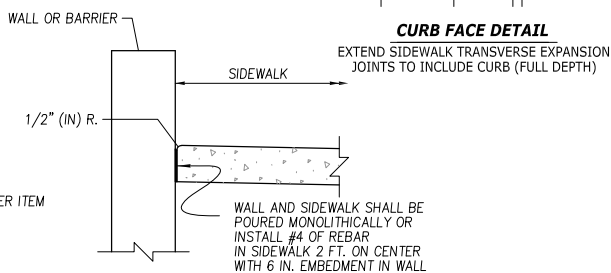

CURB FACE DETAIL
EXTEND SIDEWALK TRANSVERSE EXPANSION JOINTS TO INCLUDE CURB (FULL DEPTH)

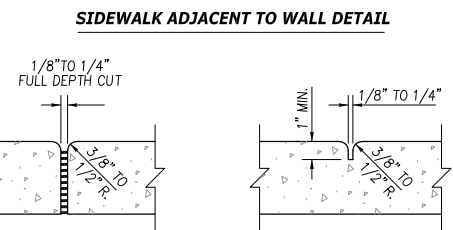

(E) EXPANSION JOINT

(C) CONTRACTION JOINT

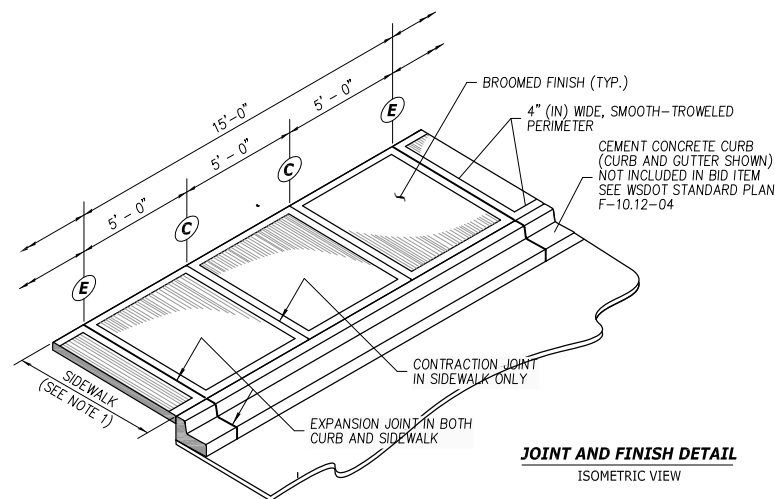

JOINT AND FINISH DETAIL
ISOMETRIC VIEW

GENERAL NOTES:

1. MATERIALS AND CONSTRUCTION REQUIREMENTS SHALL BE PER LATEST EDITION OF WSDOT STANDARD SPECIFICATIONS FOR ROAD, BRIDGE, AND MUNICIPAL CONSTRUCTION.
2. FOUR FEET OF SIDEWALK WIDTH SHALL BE THE MINIMUM PEDESTRIAN ACCESSIBLE ROUTE FREE OF VERTICAL AND HORIZONTAL OBSTRUCTIONS.
3. GRATINGS, ACCESS COVERS, JUNCTION BOXES, CABLE VAULTS, PULL BOXES AND OTHER APPURTENANCES WITHIN THE SIDEWALK MUST HAVE SLIP RESISTANT SURFACES, BE FLUSH WITH SURFACE, AND MATCH GRADE OF THE SIDEWALK.
4. A REVERSE SLOPE ON SIDEWALK MAY BE ALLOWED WITH CITY ENGINEER APPROVAL TO ACCOMMODATE THE INSTALLATION OF LOW IMPACT DEVELOPMENT BMP'S.
5. A REDUCED WIDTH OF SIDEWALK MAY BE ALLOWED WITH CITY ENGINEER APPROVAL TO ACCOMMODATE THE INSTALLATION OF LOW IMPACT DEVELOPMENT BMP'S.
6. SIDEWALK SHALL BE PLACED OVER 2" (INCH) CSTC.

APPROVED FOR PUBLICATION

Paul A. Bucich
Paul A. Bucich, P.E.
PUBLIC WORKS DIRECTOR/CITY ENGINEER

01/25/22
DATE



Public Works Department

DATE REVISION DESCRIPTION BY APPROVED

11/05/19 ORIGINAL DRAWING AD/CD PAB

1/25/22 FR-17 to FR-04 correction CD/TH PAB

6000 Main Street SW 98499

NOT TO SCALE

**Cement Concrete
Sidewalk**

FR-03

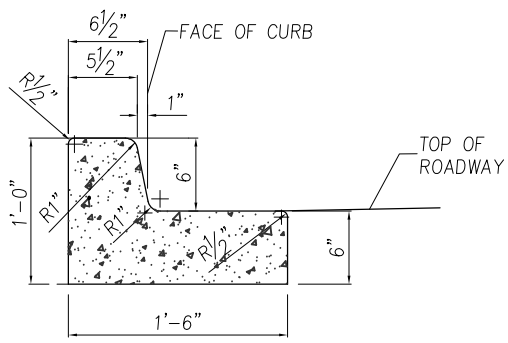

TRAFFIC CURB AND GUTTER

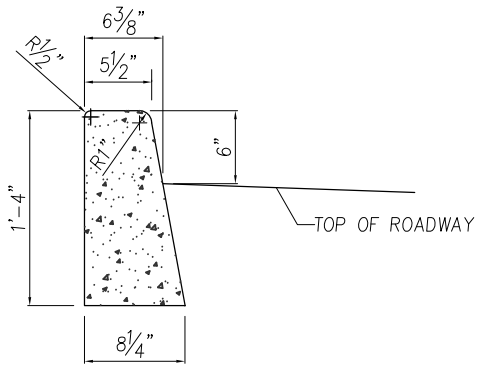

TRAFFIC BARRIER CURB

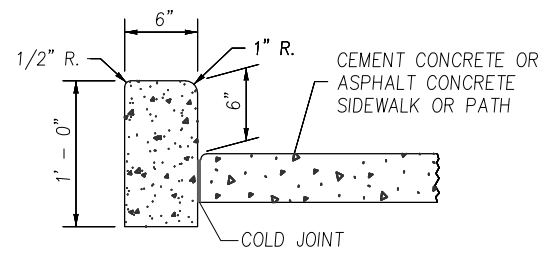

PEDESTRIAN CURB

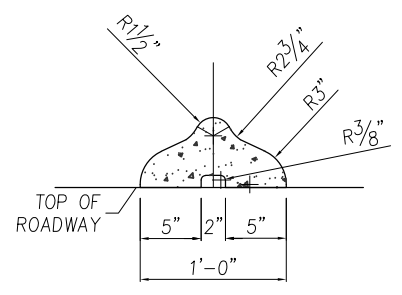

TYPE "C" CURB

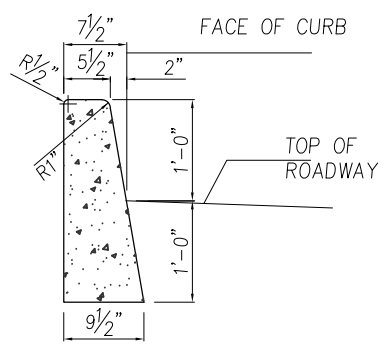

TRUCK BARRIER CURB

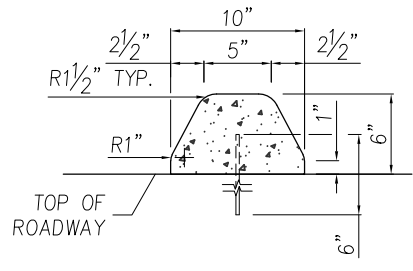

EXTRUDED CURB

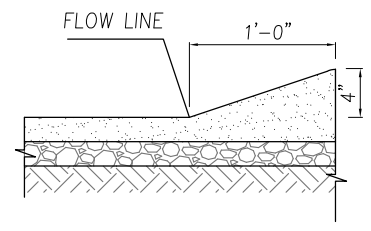

HMA WEDGE CURB

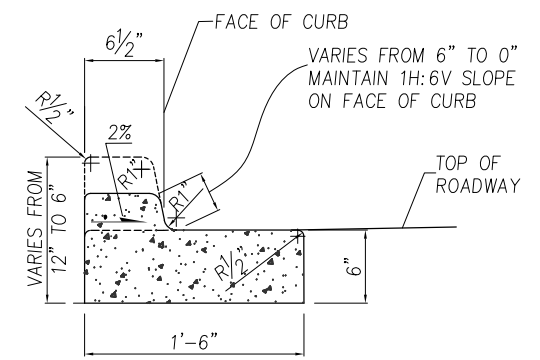

DEPRESSED CURB AND GUTTER
(AT CURB RAMPS AND DRIVEWAY ENTRANCES)

GENERAL NOTES:

1. MATERIALS AND CONSTRUCTION REQUIREMENTS SHALL BE PER LATEST EDITION OF WSDOT STANDARD SPECIFICATIONS FOR ROAD, BRIDGE, AND MUNICIPAL CONSTRUCTION.

APPROVED FOR PUBLICATION

Paul A. Bucich 11/16/20
 Paul A. Bucich, P.E.
 PUBLIC WORKS DIRECTOR/CITY ENGINEER



Public Works Department

DATE	REVISION DESCRIPTION	BY	APPROVED
11/2/09	ORIGINAL DRAWING	AD	DEW
2/28/12	REVISED DRAWING	TB/LC	DEW
3/2/15	REMOVED TYPE "C" CURB	LC	DEW
9/7/17	REVISED DRAWING	TJM	DEW
11/16/20	REVISED DRAWING	CD	PAB

6000 Main Street SW 98499

NOT TO SCALE

Curbs

FR-04

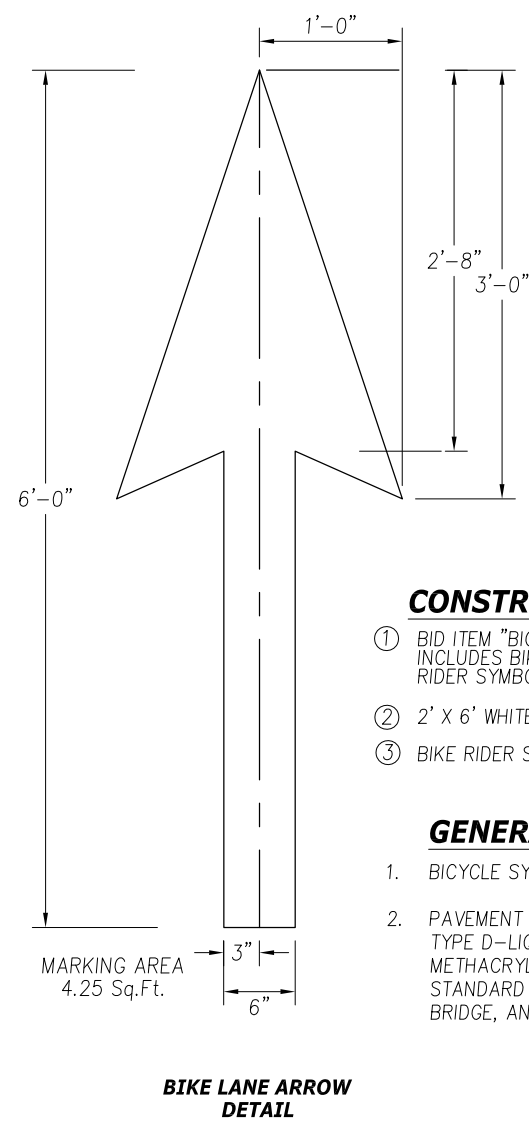
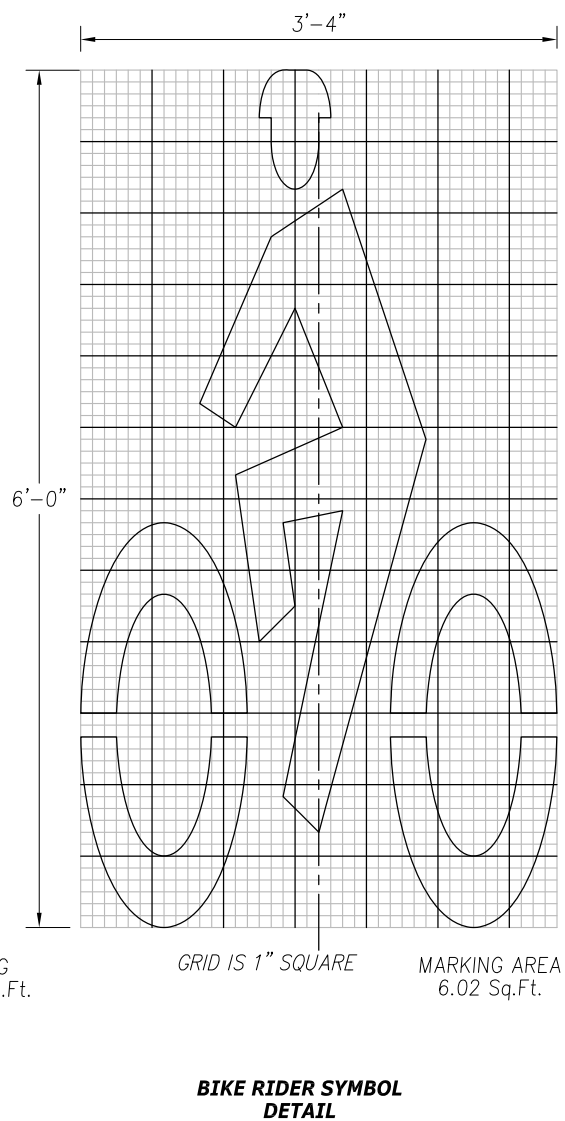
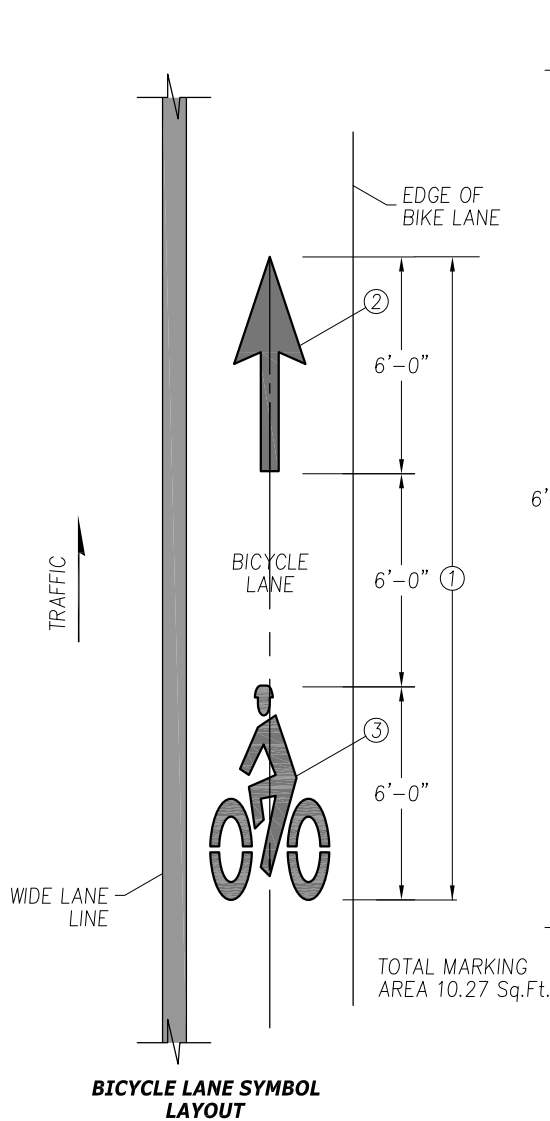

CONSTRUCTION NOTES:

- ① BID ITEM "BICYCLE LANE SYMBOL" INCLUDES BIKE LANE ARROW AND BIKE RIDER SYMBOL
- ② 2' X 6' WHITE BIKE LANE ARROW
- ③ BIKE RIDER SYMBOL

GENERAL NOTES:

- 1. BICYCLE SYMBOLS SHALL BE WHITE.
- 2. PAVEMENT MARKING SHALL BE PLASTIC TYPE D-LIQUID COLD APPLIED METHYL METHACRYLATE (MMA) PER WSDOT STANDARD SPECIFICATIONS FOR ROAD, BRIDGE, AND MUNICIPAL CONSTRUCTION.

APPROVED FOR PUBLICATION

Paul A. Bucich 01/10/20
 Paul A. Bucich, P.E.
 PUBLIC WORKS DIRECTOR/CITY ENGINEER



Public Works Department

DATE	REVISION DESCRIPTION	BY	APPROVED
12/27/19	ORIGINAL DRAWING	AD/CD	PAB

6000 Main Street SW 98499

NOT TO SCALE

Bicycle Lane Symbol Layout

PS-04

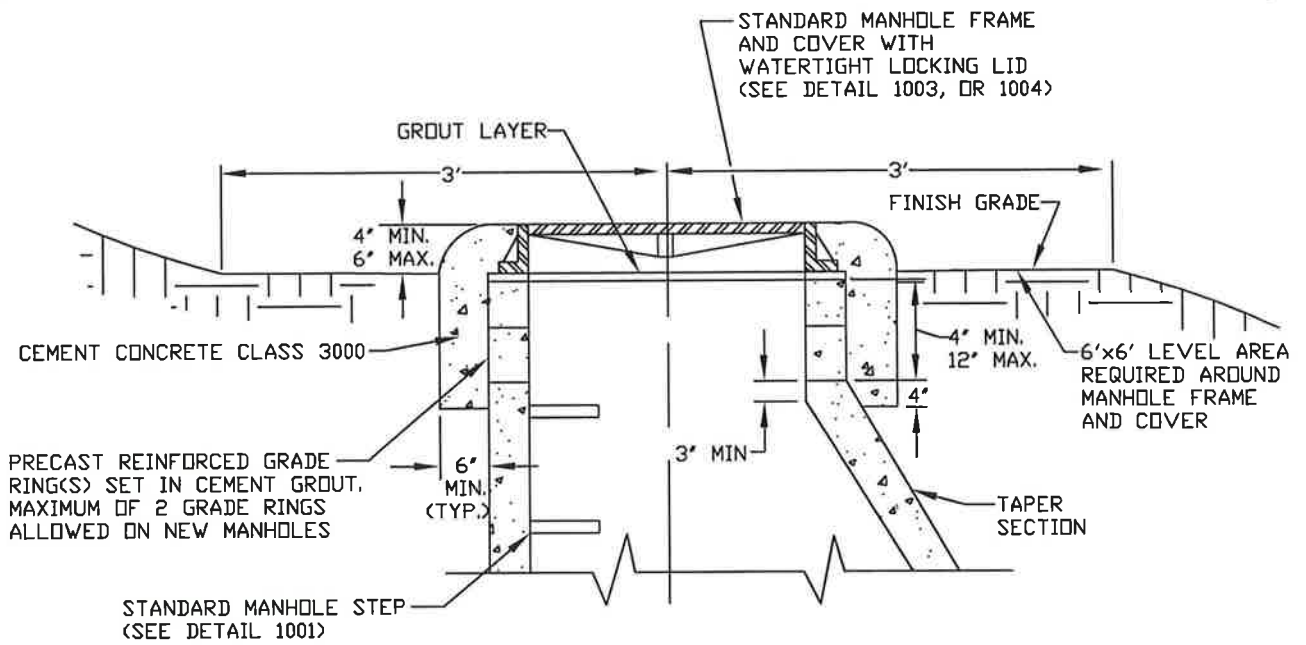

NON-PAVED AREA

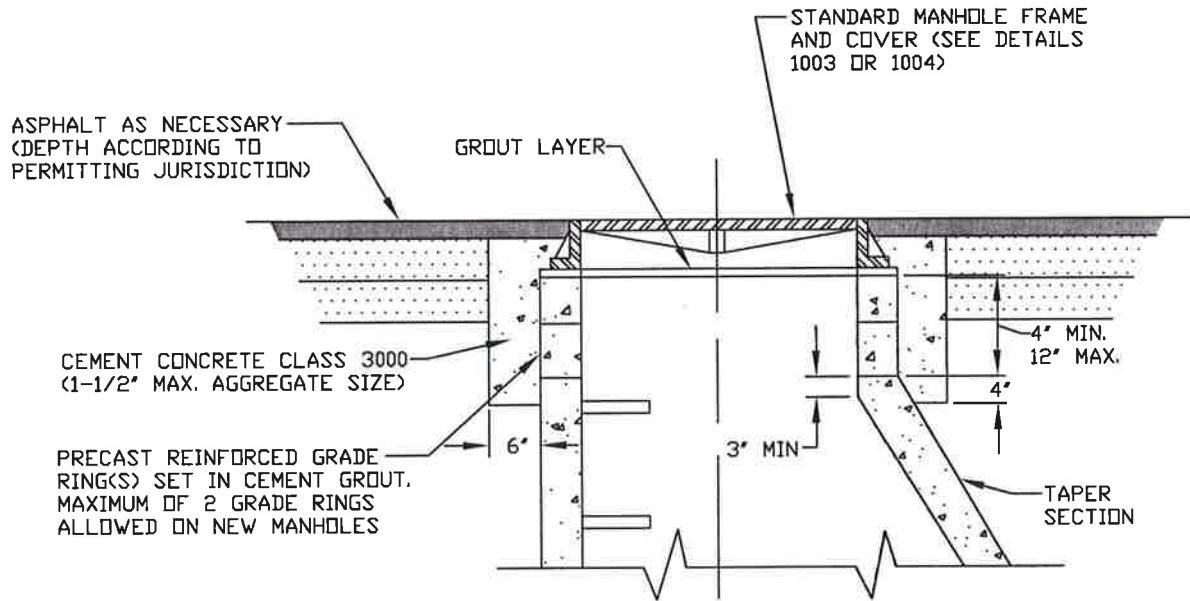

PAVED AREA



PIERCE COUNTY PUBLIC WORKS & UTILITIES DEPARTMENT
SEWER UTILITY DIVISION
9850 64TH STREET WEST
UNIVERSITY PLACE, WASHINGTON 98487-1078
(253) 798-4050

STANDARD DETAILS

DATE
12/26/2012

SCALE
NTS

CONCRETE MANHOLE COLLAR

STANDARD DETAIL NO.

1002

PAGE 1 OF 1

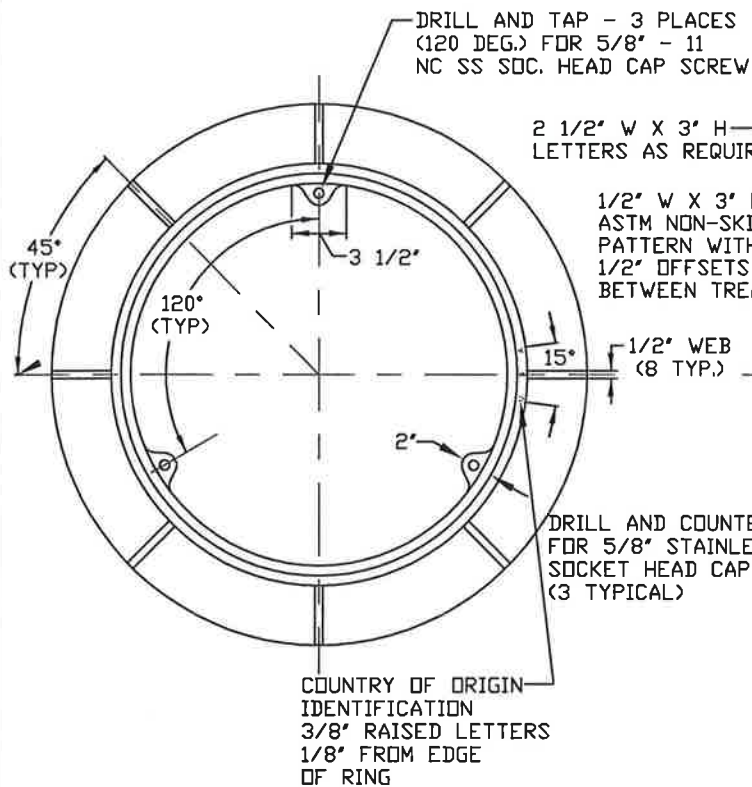

MANHOLE RING - PLAN

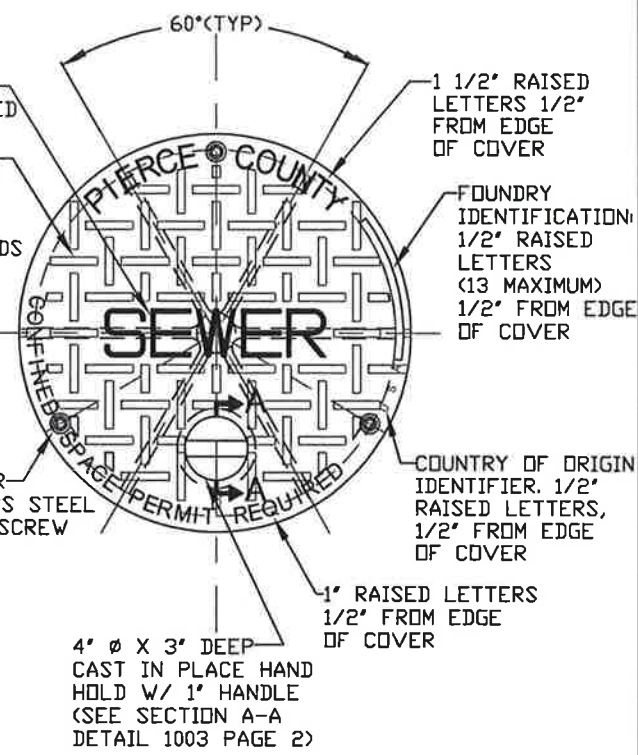

MANHOLE COVER - PLAN

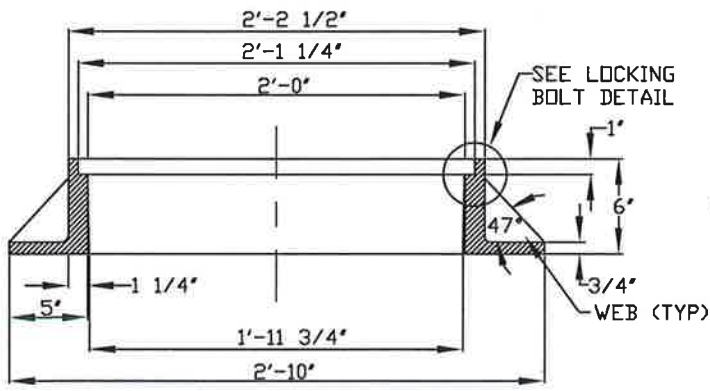

MANHOLE RING - SECTION

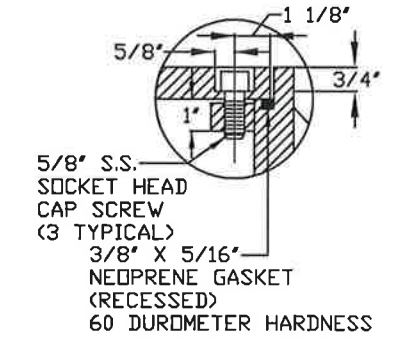
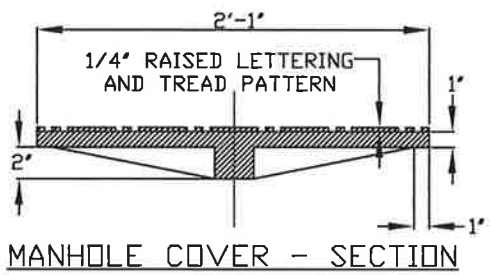

LOCKING BOLT - DETAIL
NTS



PIERCE COUNTY PUBLIC WORKS & UTILITIES DEPARTMENT
SEWER UTILITY DIVISION
9850 64TH STREET WEST
UNIVERSITY PLACE, WASHINGTON 98467-1078
(253) 798-4050

STANDARD DETAILS

DATE
05/01/2011

SCALE
NTS

**PUBLIC MANHOLE FRAME
AND LOCKING LID**

STANDARD DETAIL NO.
1003
PAGE 1 OF 2